



PLANNING PROPOSAL

REZONE SUBJECT SITE FROM RU2 – RURAL LANDSCAPE TO R5 – LARGE LOT
RESIDENTIAL

ELTONS ROAD / TAYLORS ROAD | SILVERDALE

PLANNING
I N G E N U I T Y



PLANNING PROPOSAL

REZONE SUBJECT SITE FROM RU2 – RURAL LANDSCAPE TO R5 – LARGE LOT
RESIDENTIAL

ELTONS ROAD / TAYLORS ROAD | SILVERDALE

PROJECT REF: 0140/11

DATE: FEBRUARY 20, 2012

PLANNING
I N G E N U I T Y

CONTENTS

1	INTRODUCTION	1
2	LOCALITY AND SITE ANALYSIS.....	2
2.1	Site Identification	2
2.2	Site Characteristics	3
2.2.1	Ecology	4
2.2.2	Bushfire	5
2.2.3	Aboriginal Heritage.....	5
2.2.4	Non-Indigenous Heritage	5
2.2.5	Water and Sewer Servicing.....	5
2.2.6	Traffic	6
2.3	Site Context	11
2.4	Current Zoning.....	12
3	PLANNING PROPOSAL.....	15
3.1	Part 1 - Objectives or Intended Outcomes	15
3.1.1	Intended Outcomes	15
3.1.2	Objectives	15
3.2	Part 2 - Explanations of Provisions	15
3.3	Part 3 - Justification	20
	SECTION A – Need for the Planning Proposal	20
	SECTION B – Relationship to strategic planning framework.....	24
3.4	Where this direction applies	44
3.5	What a relevant planning authority must do if this direction applies.....	44
3.6	Consistency	44
	SECTION C – Environmental, Social and Economic Impact.....	47
	SECTION D – State and Commonwealth Interests	49
3.7	Part 4 - Community Consultation	50
4	CONCLUSION	52

ANNEXURES

- A. Ecology and Bushfire Constraints Report – *Eco Logical Australia*
- B. Aboriginal Heritage Due Diligence Assessment and Preliminary Non-Indigenous Heritage Assessment – *Artefact Heritage Consultants*
- C. Water and Sewer Servicing Report – *Martens Consulting Engineers*
- D. Traffic Impact Review – *McLaren Traffic Engineering*
- E. Constraints Map – *Taylor Brammer Landscape Architects*
- F. Conceptual Development Areas Plan – *Taylor Brammer Landscape Architects*

©This document and the research reported in it remains the property of Planning Ingenuity Pty Ltd and are protected by copyright. Apart from fair dealings for the purposes of private study, research or review, as permitted under the *Copyright Act 1968*, no part of the document may be reproduced, by any process, without the written permission of the author. All inquiries in this regard are to be directed to the Director, Planning Ingenuity Pty Ltd.

1 INTRODUCTION

This Planning Proposal has been prepared for a group of individual landowners that own allotments within the subject site, and it accompanies a request for a Gateway Determination under the provisions of Section 56 of the Environmental Planning & Assessment (EP&A) Act, 1979. The landowners have grouped together with the primary intent of providing an integrated approach to future planning and development of the site.

The subject land, which is described in detail in Section 2, can generally be described as the properties located north of Eltons Road, east of Silverdale Road, south of St Heliers Road and Barrington Road, and west of Taylors Road.

The Planning Proposal seeks to rezone the subject site from RU2 - Rural Landscape to R5 – Large Lot Residential. The Planning Proposal also seeks to reduce minimum allotment sizes from 16 hectares to 4,000m² to allow future rural residential subdivision including new roads and open space areas, low density rural residential dwellings and associated landscaping.

The proposed future development of the site is consistent with the Local and State Government Policies that are designed to drive the environmental, social and economic outcomes of New South Wales. Of particular relevance to the proposal is the *Wollondilly Shire Council – Growth Management Strategy 2011* which identifies the site as a “potential residential growth area”. The Strategy identifies a total dwelling target of 1,000 dwellings for Silverdale/Warragamba and notes that just over half of the total dwelling target is met by current planning.

The planning proposal has been prepared in accordance with Section 55 of the Environmental Planning & Assessment Act, 1979, as well as the NSW Department of Planning publications “*A Guide to Preparing Planning Proposals*” and “*A Guide to Preparing Local Environmental Plans*”.

As outlined in *A Guide to Preparing Planning Proposals* the planning proposal will evolve throughout the course of preparing the amending LEP as relevant sections will be updated and amended in response to the outcomes of further technical investigations and consultation. Notwithstanding, this Planning Proposal has relied on and been informed by detailed investigations by a diverse range of consultants. Accompanying this planning proposal are the preliminary studies listed below:

- A. Ecology and Bushfire Constraints Report – *Eco Logical Australia*
- B. Aboriginal Heritage Due Diligence Assessment and Preliminary Non- Indigenous Heritage Assessment – *Artefact Heritage Consultants*
- C. Water and Sewer Servicing Report – *Martens Consulting Engineers*
- D. Traffic Impact Review – *McLaren Traffic Engineering*
- E. Constraints Map – *Taylor Brammer Landscape Architects*
- F. Conceptual Development Areas Plan – *Taylor Brammer Landscape Architects*

This report is divided into four sections. The remaining sections include a locality and site analysis; the Planning Proposal; and a conclusion.

2 LOCALITY AND SITE ANALYSIS

2.1 Site Identification

The subject site comprises approximately 200 hectares of land, comprising several allotments within the township of Silverdale. The subject site is located within an area that can be generally described as north of Eltons Road, east of Silverdale Road, south of St Heliers Road and Barrington Road, and west of Taylor's Road (see Figure 1).

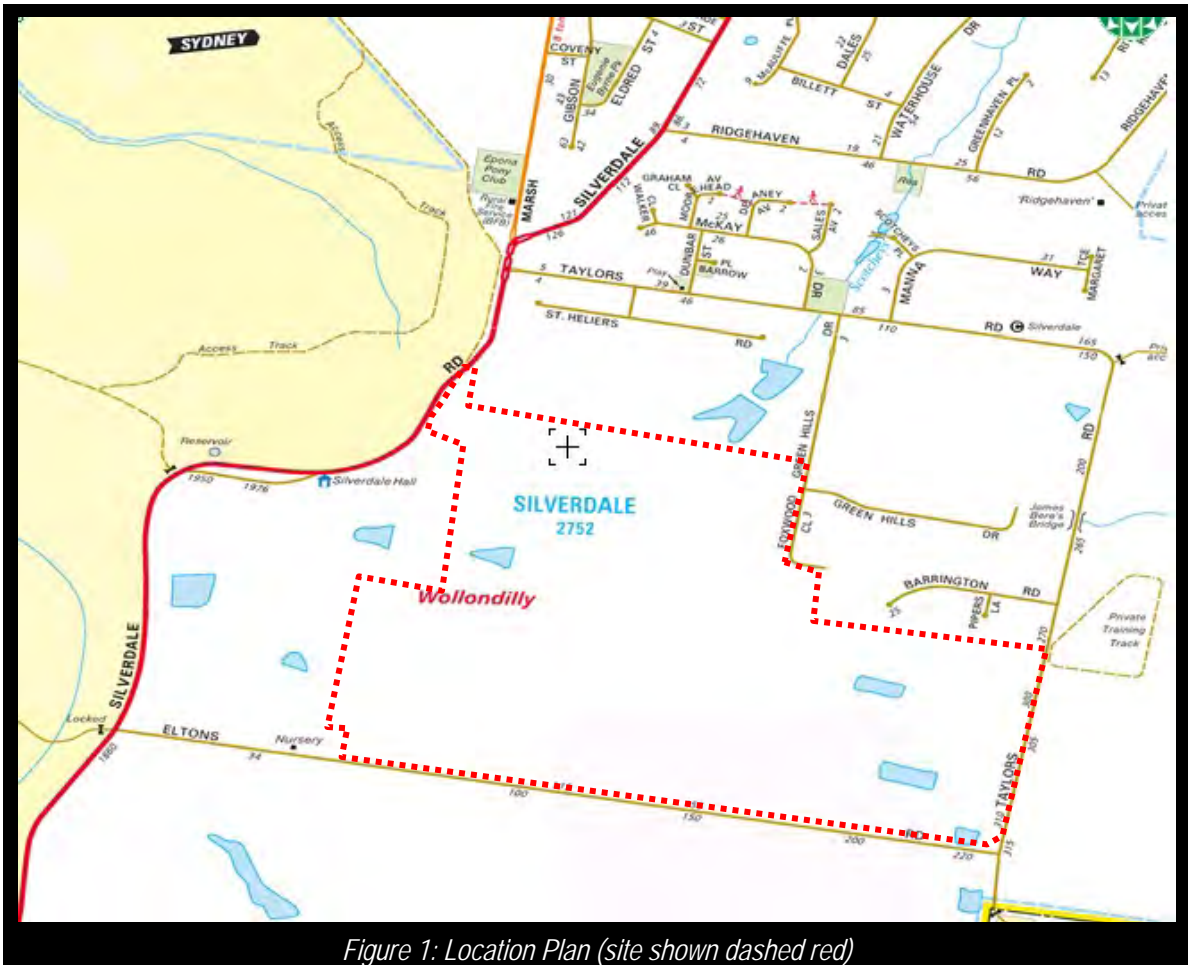

The subject site is owned by several individual landowners. The allotments that form the site, the size and the owners of these parcels are listed in Table 1. Several of these owners have joined as a group, to act as applicants for this Planning Proposal with the intent of pursuing an integrated planning approach for the subject site.

The owners of Lot 300 in DP 1076326 and Lot 2 in DP 562249, immediately to the north of land owned by our clients, were invited to join as applicants for an integrated Planning Proposal including all of this land however have opted not to. The owner of Lot 300 in DP 1076326 has since submitted a Planning Proposal seeking rezoning of that lot in isolation to R2 – Low Density Residential. Additionally, we do not act for the owners of Lots 48 to 51 in DP 236542 or Lot 3 in DP 734838 which are smaller allotments fronting Eltons Road.

Following pre-submission discussions with Council it was considered desirable from a town planning point of view to prepare this Planning Proposal to include contiguous land between Lot 300 in DP 1076326 and Eltons Road. Therefore, whilst we do not act for the owners of Lot 2 in DP 562249 or the smaller allotments fronting Eltons Road this Planning Proposal has been prepared to include these parcels of land. In some instances, access to these allotments was not permitted for various consultants and therefore desktop analysis and assumptions on environmental attributes have been made on the basis of mapping and adjoining land where necessary. We also note that the western boundary of the site has generally been informed by the natural drainage catchment, rather than the existing road pattern in the locality. That is, land within the Sydney Drinking Water Catchment has been excluded.

In the interests of an integrated strategic planning approach, we respectfully request that the Planning Proposal for Lot 300 in DP 1076326 and the subject Planning Proposal be considered simultaneously by Council and the Department of Planning.

TABLE 1: Identification of Subject Site		
Lot and DP	Site Area by title (ha)	Owner
Lot 48 in DP 236542	2.023	Michael Joseph Kavazos & Judith Ann Toohey
Lot 49 in DP 236542	2.023	Jeremy Michael & Andrea Smith
Lot 50 in DP 236542	2.023	Seamus Thomas & Margaret Mary Smith
Lot 51 in DP 236542	2.023	Rossario Luppino
Lot 52 in DP 236542	32.38	Jabam P/L
Lot 12 in DP 247872	10.19	Antonietta Alloggia
Lot 13 in DP 247872	10.13	Mario & Pasquale Coratza
Lot 14 in DP 247872	10.12	Joe, Sylvia & Joseph Attard
Lot 15 in DP 247872	10.12	Concetta & Giovanna Trunzo
Lot 16 in DP 247872	14.16	Osman & Neriman Simsek
Lot 2 in DP 562249	21.45	Ross Bernard & John William Fowler
Lot 11 in DP 578088	15.77	Jose, & Josephine Maria De Aquino
Lot 1 in DP 734838	16.00	Kruno, Ika, Grego & Mary Gurlica
Lot 2 in DP 734838	16.45	Kruno, Ika, Grego & Mary Gurlica
Lot 3 in DP 734838	1.943	John William & Susan Dawn Harding
Total	166.805 ha	

2.2 Site Characteristics

Figure 2 includes an aerial image of the subject site and Figure 3 includes mapping of the properties identified in Table 1. As can be seen, the subdivision pattern in the locality is irregular with vast variation in allotment sizes. The individual lot sizes within the subject site vary between 2 hectares and 32 hectares, with the smaller lots being located along Eltons Road.

The topography of the site is also described in Figure 3. Generally the land slopes from west to east with a gradual slope of approximately 50m from the western boundary of the site to its eastern boundary. The site contains several depressions including several farm dams as well as natural watercourses.

The land is burdened by several drainage easements as noted in Figure 3. Most notably, an easement for transmission line with a width of 30.48m traverses the western part of the site in a north-west to south-east direction.

The properties within the subject site are generally in rural-residential use with some accommodating a small number of hobby animals, or "passive" agriculture in the form of low intensity hobby grazing. In addition, No. 45 Eltons Road contains a small wholesale nursery, 2054 Silverdale Road a small hobby orchard and 71 Eltons Road, a small market garden (refer to Figure 5 for site photographs). Accordingly, the site cannot be considered to contain any significant viable productive agriculture but rather comprises several rural lifestyle allotments.

The environmental attributes of the site have been identified in a series of consultant reports. The site attributes identified in these reports are summarised below in Sections 2.2.1 to 2.2.6. In addition, a Constraints Map has been prepared by Taylor Brammer Landscape Architects, developed through an overlay mapping exercise. This exercise has assisted with developing an understanding of potential development areas on the subject site (refer to Annexure E or Figure 4).

2.2.1 Ecology

The ecological attributes of the site as discussed in detail in the *Ecology and Bushfire Constraints Report* by Eco Logical Australia (Annexure A) can be summarised as follows:

" Vegetation

The NSW NPWS (2002) Western Sydney vegetation mapping for this area showed a mixture of vegetation communities present on the site, in a variety of ecological conditions. These included:

- Cumberland Plain Woodland (both Shale Hills and Shale Plains sub communities)
- Shale Sandstone Transition Forest (both the low and high sandstone influence sub-communities)
- Moist Shale Woodland, and
- Several areas of unclassified vegetation.

Much of the remnant vegetation on site remains in good condition and has a moderate to good recovery potential. There is good canopy cover if most of the patches remaining onsite. Current land management practices such as grazing, slashing and mowing are severely impacting the mid-storey and ground cover layers at present, however if these influences were removed or modified, the level of natural regeneration likely to occur is considered to be quite high.

Flora

The NSW Wildlife Atlas search (now Bionet) lists a total of 6 threatened plant species as occurring within a 10km radius of the site. Additionally, the Commonwealth database lists a total of 14 threatened plant species as occurring within a 10km radius of the site. No threatened flora species were identified on site during the survey, however the survey effort was not exhaustive. A list of all flora species observed on site is included in Appendix B.

Fauna

The NSW Wildlife Atlas search lists a total of 22 threatened fauna as being recorded within 10km of the site, while the Commonwealth database lists a total of 19 threatened fauna species and 12 migratory birds within a 10km radius. No listed threatened fauna species were encountered on site during the limited field survey. Numerous trees on site contain hollows which could be utilised by a range of fauna species, including several of the listed bat species. Also, the site's close proximity to large areas of good quality habitat in the Warragamba Catchment Lands and the Gulguer Nature Reserve / Bents Basin State Conservation Area increase the likelihood that some of these threatened species would utilise the site from time to time. A list of the fauna species observed on site is included in Appendix B.

Riparian

There are several watercourses within the subject site: the location of the numbered stream reaches is shown in Figure 4. The majority of the stream reaches on site have had the majority of remnant streambank vegetation removed or highly modified over time, with little natural riparian vegetation

remaining. The banks of the watercourses are in reasonable condition in most parts, however there are some significant localised erosion points particularly, in the steeper sections in the south-west portion. Overall the riparian corridors have a moderate to good natural recovery potential."

2.2.2 Bushfire

The bushfire attributes of the site as discussed in detail in the *Ecology and Bushfire Constraints Report* by Eco Logical Australia (Annexure A) can be summarised as follows:

" The subject site contains several areas of Bushfire Prone Land according to Wollondilly Shire Council's Bushfire Prone Lands map. There is a large area of remnant native vegetation within the site, as well as several patches of vegetation existing on adjacent lands which present a bushfire hazard to the subject. The Bushfire Prone Lands within the subject site are shown in Figure 5. A combination of vegetation categories 1 and 2 are present on site. The large area of SSTF vegetation on site (located mainly within Lot 52 DP 236542 and Lot 16 DP 247872) is unlikely to be approved for removal or substantial modification, hence the bushfire threat posed to the surrounding lands by this patch will remain."

2.2.3 Aboriginal Heritage

The aboriginal heritage attributes of the site as discussed in detail in the *Aboriginal Heritage Due Diligence Assessment and Preliminary Non- Indigenous Heritage Assessment* by Artefact Heritage Consultants (Annexure B) can be summarised as follows:

- "
- There are no recorded Aboriginal sites within the study area;
 - The central portion of the study area has been assessed as having a moderate archaeological potential."

2.2.4 Non-Indigenous Heritage

The site's Non-Indigenous heritage attributes as discussed in detail in the *Aboriginal Heritage Due Diligence Assessment and Preliminary Non- Indigenous Heritage Assessment* by Artefact Heritage Consultants (Annexure B) can be summarised as follows:

- "
- There are no non-Indigenous heritage listed sites within the study area;
 - Two heritage listed sites within the vicinity of the study area will not be impacted by the proposed rezoning;
 - There is a low potential for non-Indigenous archaeological remains to be present within the study area."

2.2.5 Water and Sewer Servicing

The infrastructure servicing attributes of the site as discussed in detail in the *Water and Sewer Servicing Report* by Martens Consulting Engineers (Annexure C) can be summarised as follows:

" **Water**

Advice obtained from Sydney Water indicates that there are several existing water mains near to the study area (refer to site plans in Attachment A), detailed as follows:

1. 100 mm uPVC main in St Heliers Road (north of Lot 300 adjacent to study area).
2. 100 mm uPVC main in Foxwood Close.
3. 100 mm uPVC main in Taylors Road (north of existing lot 12 D.P. 247872).
4. 100 mm uPVC main on the eastern side of Silverdale Road (west of Lot 300 and north-west of study area).
5. Sydney Water has also indicated that there is a 375 mm main on the western side of Silverdale Road, however, it is not known if this main is a dedicated supply main or if connection to this main would be possible.

Sewer

The nearest existing sewerage connection point to the study area is the existing 150 mm sewer main in St Heliers Road to the north of the study area. This main connects to another 150 mm main in Taylors Road. Preliminary analyses indicate that the load on the sewer main in Taylors Road is approximately 252 EP (72 lots at 3.5 EP/lot)."

2.2.6 Traffic

The site's road and traffic attributes as discussed in detail in the Traffic Impact Review by McLaren Traffic Engineers (Annexure D) can be summarised as follows:

“ **Road Hierarchy**

Silverdale Rd, Mulgoa Road and Park Road are regional roads under the care and control of both the Roads and Traffic Authority and Wollondilly Shire Council. Eltons Road and St Heliers Road are local roads under the care and control of Wollondilly Shire Council.

Existing Traffic Management

Priority control intersection traffic management conditions apply for all junctions within the immediate vicinity and surrounding environs of the site. A single lane roundabout control exists at the intersection of Silverdale Road, Mulgoa Road and Park Road.

Existing Traffic Volumes

The existing traffic volumes on the roads surrounding the site are described below in terms of either Average Annual Daily Traffic (AADT). The RTA publication, Traffic Volume Data for the Sydney Region, 2002 contains AADT volumes for most major roads in the Sydney metropolitan area. The AADT figure at a given point represents the average number of axle pairs passing in both directions in a 24 hour period, estimated over a period of one year. The AADT for Silverdale Road at the Nepean River Bridge in 2002 was 8201 vehicles.

Traffic Flows

McLaren Traffic Engineering has undertaken existing weekday morning peak hour counts on 18th November 2011, from 6:00am to 9:00am at the intersection of Silverdale Road with Mulgoa Road and Park Road. The evening peak hour counts were estimated based on the morning peak hour counts and was assumed to occur from 5.00 to 6.00 PM. The results of the peak hour intersection counts are shown in Figure 2. It is important to note that the weekday morning peak period occurs at 7:00am to 8:00am for the intersection shown in Figure 2.

Public Transport Services

Public buses do not currently operate along Eltons Road or St Heliers Road; however a bus service currently operates along Silverdale Road to the west of the proposed development. There is currently 1 bus route that services the segment of Silverdale Road adjacent to the site (shown in Annexure B). Route 32 provides access to the south of the development and as far north as Warragamba. Catching the public buses any further north requires changing buses at Warragamba and taking Route 795.”



Figure 2: Aerial Photo (site shown dashed red)

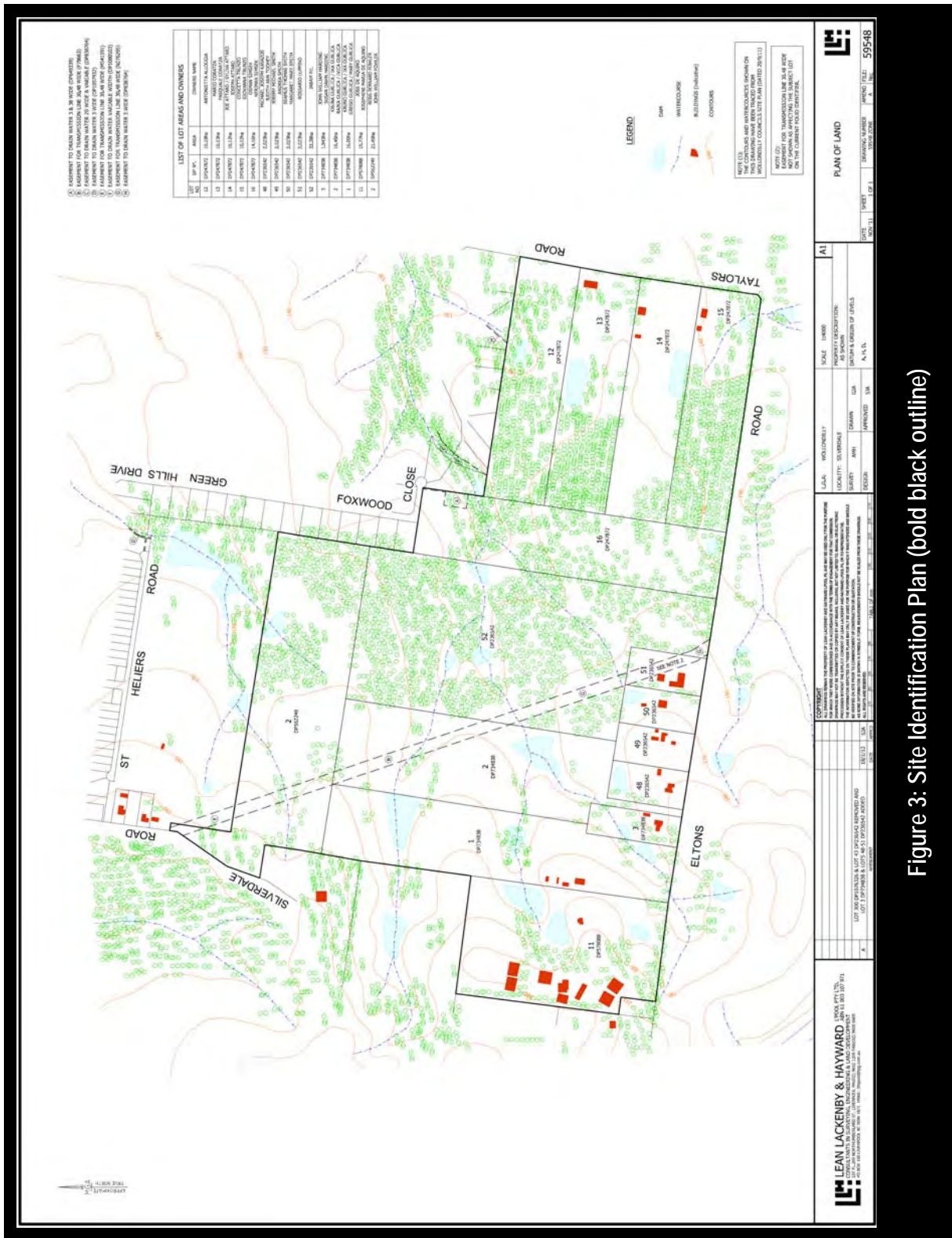

Figure 3: Site Identification Plan (bold black outline)

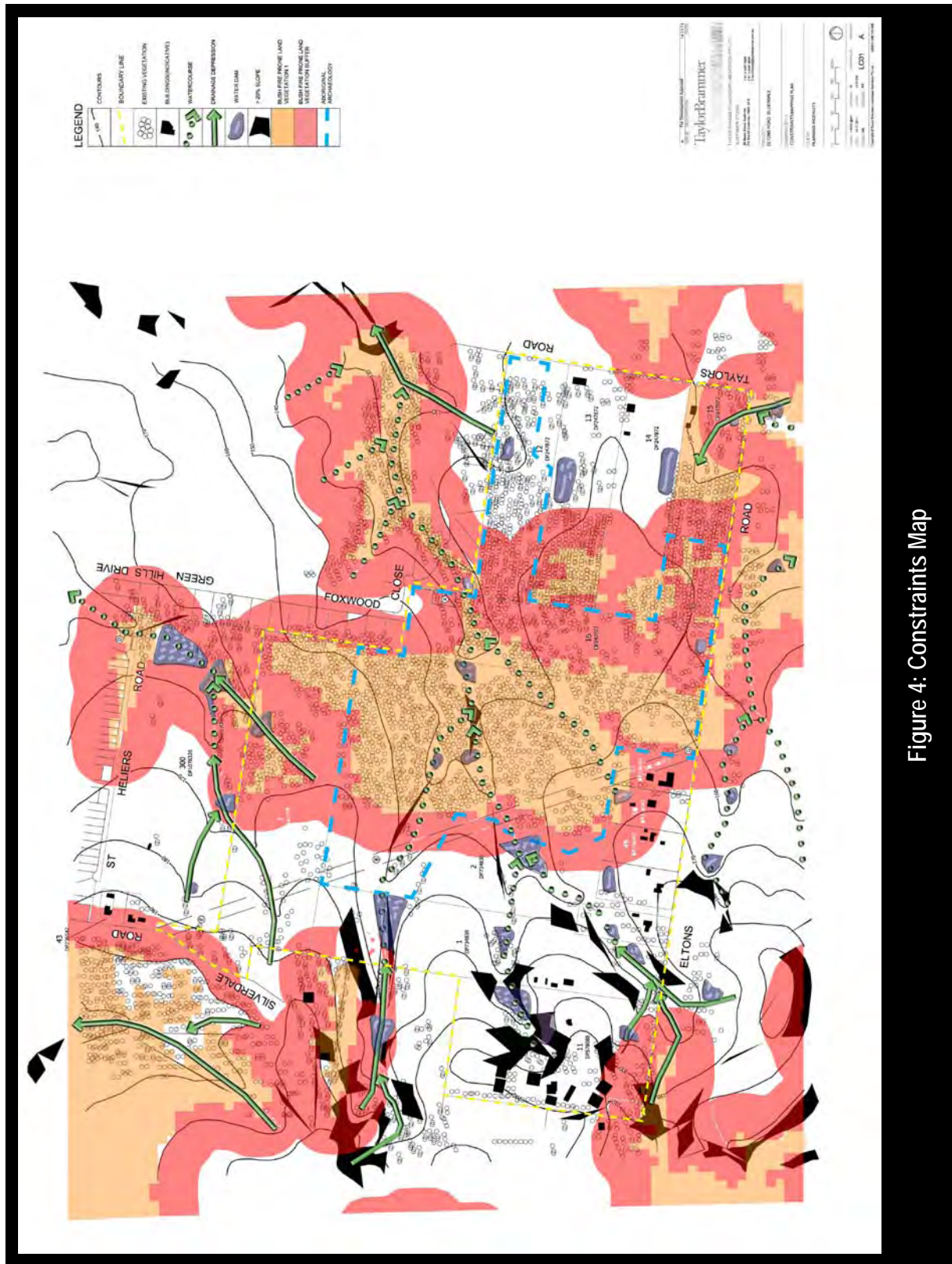

Figure 4: Constraints Map



2.3 Site Context

The site is located on the southern side of the township of Silverdale and is bordered by Silverdale Road to the west, Eltons Road to the south and Taylors Road and Green Hills Drive to the north and east. Silverdale features a small shopping centre approximately 3km from the subject site, which includes a supermarket, professional services, specialty stores and a service station. Various other services are dotted throughout the Silverdale Township itself.

The surrounding locality also exhibits stark contrasts in residential allotment sizes. Immediately to the north-east, the subject site adjoins large lot residential subdivisions accessed by Foxwood Close, Greenhills Drive and Barrington Road with allotment sizes generally in the order of 3,000m² to 4,000m². These properties are all occupied by single residential dwellings and do not incorporate any agricultural uses. To the north is Lot 300 in DP 1076326 which is the subject of a Planning Proposal to rezone land from RU2 to R2 – Low Density Residential. Further to the adjoining the northern boundary of Lot 300 is a residential subdivision along St Heliers Road which comprises allotments generally in the order of 800 to 900m². These properties exhibit the character of typical suburban residential development in terms of lot sizes, dwelling types, site landscaping and streetscape.

To the west of the subject properties and extending towards Silverdale Road are larger allotments, similar in character to the subject site. To the south, on the opposite side of Eltons Road, is larger lot development including an olive farm. Whilst the street frontage on the southern side of Eltons Road comprises some smaller lots which have been excised from the larger holdings, the southern side of Eltons Road has a lower density, more rural character than the northern side. Some land to the south is the subject of a land owner nominated potential housing site in response to the NSW Department of Planning and Infrastructure request for Expressions of Interest.

Silverdale is located 2.5 km from the historic Warragamba Township, which is the location for Sydney's largest dam and key water catchment area. The subject site is within a short distance of the Burragorang State Recreation Area and the Nepean River, which is westward of Silverdale Road and stretches to the Blue Mountains in the north-westerly direction.

In a broader context, two of out five of Sydney's key Regional Centres are located approximately 30km from the subject site. Penrith is located approximately 23km to the north of the subject site, and is defined as a Regional Centre by the NSW Department of Planning. Penrith features a large range of facilities and services such as schools, hospitals, shopping centres and employment opportunities. Liverpool, another Regional Centre is located approximately 30km to the east, of the subject site and also features a large range of facilities and services such as schools, hospitals, shopping centres and employment opportunities. The Major Centre of Campbelltown, is approximately 38km to the south-east, and also features a large range of services and facilities.

The subject site is approximately 26km west of the M7 Motorway at the Elizabeth Drive entrance, which connects Western Sydney with key Sydney Motorways such as the M4, M2 and M5, providing fast access to various parts of Sydney, particular employment opportunities in the west and south-west of Sydney and facilities such as the Sydney CBD, Sydney Kingsford Smith Airport, Port Botany, Macquarie Park and other key facilities in Sydney. On a broader basis the M7 Motorway is a ring road which offers links Sydney with Canberra and Melbourne via the M5 and links northward towards Newcastle and Brisbane via the M2.

2.4 Current Zoning

Wollondilly Local Environmental Plan (WLEP) 2011 is the primary local environmental planning instrument for the Wollondilly LGA. Under this instrument the zone '*RU2 – Rural Landscape*' applies to the subject site as shown in Figure 6 of this report. The zone objectives and permissible uses are stated as follows:

- " **Zone RU2 Rural Landscape**
- 1 **Objectives of zone**
 - To encourage sustainable primary industry production by maintaining and enhancing the natural resource base.
 - To maintain the rural landscape character of the land.
 - To provide for a range of compatible land uses, including extensive agriculture.
 - To provide areas where the density of development is limited in order to maintain a separation between urban areas.
 - 2 **Permitted without consent**
 - Extensive agriculture; Home occupations
 - 3 **Permitted with consent**
 - Agriculture; Airports; Animal boarding or training establishments; Bed and breakfast accommodation; Boat building and repair facilities; Boat sheds; Cellar door premises; Cemeteries; Community facilities; Crematoria; Depots; Dwelling houses; Educational establishments; Environmental facilities; Environmental protection works; Extractive industries; Farm buildings; Farm stay accommodation; Flood mitigation works; Forestry; Freight transport facilities; Funeral homes; Group homes; Home-based child care; Home businesses; Home industries; Home occupations (sex services); Hospitals; Information and education facilities; Landscaping material supplies; Mortuaries; Places of public worship; Plant nurseries; Recreation areas; Recreation facilities (indoor); Recreation facilities (outdoor); Research stations; Roads; Roadside stalls; Rural industries; Rural supplies; Rural workers' dwellings; Secondary dwellings; Signage; Transport depots; Veterinary hospitals; Water recreation structures; Water supply systems
 - 4 **Prohibited**
 - Stock and sale yards; Turf farming; Any other development not specified in item 2 or 3"

Additionally, minimum lot sizes are also a requirement for subdivision on land subject to WLEP 2011. The site falls under an AB1 classification, which requires a minimum lot size of 16 hectares. A map showing this classification for the subject site is shown in Figure 7 of this report.

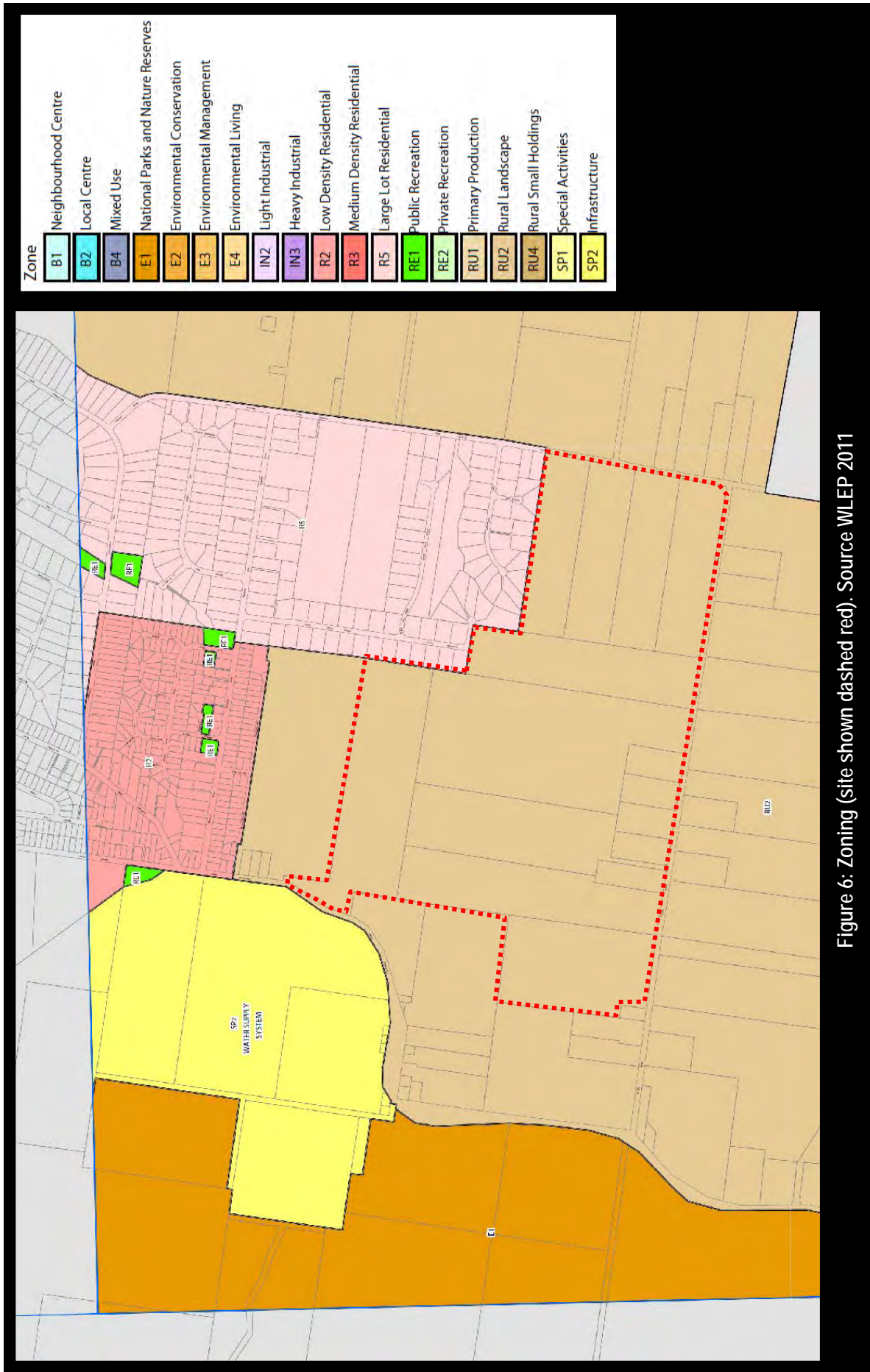

Figure 6: Zoning (site shown dashed red). Source WLEP 2011

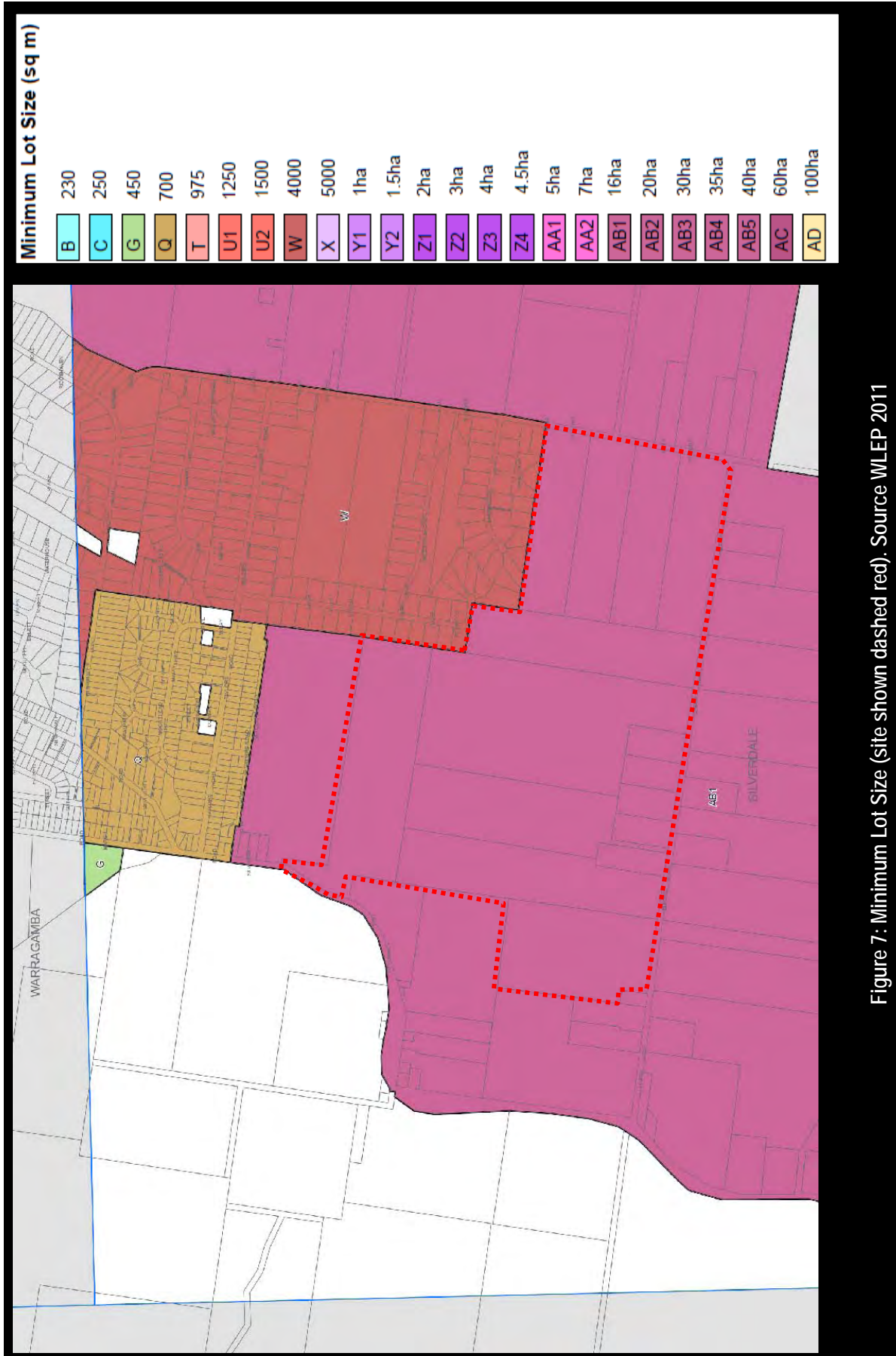

Figure 7. Minimum Lot Size (site shown dashed red). Source WLEP 2011

3 PLANNING PROPOSAL

3.1 Part 1 - Objectives or Intended Outcomes

3.1.1 Intended Outcomes

The purpose of this Planning Proposal is to establish the appropriate land use zone on the site to enable its future redevelopment for rural residential lots with a minimum lot size of 4,000m².

It is anticipated that future development of the site may proceed in a manner similar to that depicted in the "Conceptual Development Areas Plan" prepared by Taylor Brammer Landscape Architects Pty Ltd (refer to Annexure F). Whilst this Plan is conceptual and is not intended to form part of the Planning Proposal, it assists with estimating the potential allotment yield when considering site constraints. It is estimated that the Planning Proposal would yield a maximum of 193 allotments. Note that individual allotment level site constraints may further reduce this estimated yield.

3.1.2 Objectives

To achieve the intended outcome for redevelopment of the land, the objectives of this Planning Proposal are as follows:

- i. Assist with meeting dwelling targets for Silverdale identified under the Wollondilly Growth Management Strategy 2011;
- ii. Creation of a rural residential development area that will support the existing township of Silverdale and make the provision of services and infrastructure more efficient and viable;
- iii. Provide for excellent resident amenity, which is within a desirable location with access to essential local services;
- iv. Protection of ecologically sensitive parts of the site to exceed current ESD principles and Government policy requirements for sustainability and environmental protection;
- v. Consultation with the local community to ensure that future redevelopment has well considered outcomes;
- vi. Management of bushfire risks to prevent any risk to property or human life, including management of access points for emergency vehicles;
- vii. Provide for a density of development that minimises traffic flows into the surrounding street network;
- viii. Provision of infrastructure to meet the demands of the new population; and
- ix. Allow for the orderly and economic development of the land.

3.2 Part 2 - Explanations of Provisions

It is proposed to amend the Wollondilly Local Environmental Plan 2011 in the following way:

- Amend WLEP 2011 Zoning Map – Sheet LZN_006B by changing zoning of the subject site from RU2 Rural Landscape to R5 – Large Lot Residential;
- Amend WLEP 2011 Lot Size Map – Sheet LSZ_006B by including the site within "W" category of minimum 4,000m² lot size;
- Amend WLEP 2011 Height of Buildings Map – Sheet HOB_006B to include the site within "J" category subject to a 9m maximum height limit.

Refer to Figures 8, 9 and 10 which illustrate the proposed LEP amendments.

The Planning Proposal does not require amendment to any other LEP provisions. The proposal would be subject to the relevant planning controls under Wollondilly Development Control Plan 2011. The DCP does not contain any site specific provisions related to the subject site. Dependant on the outcome of final technical studies, it may be appropriate that certain site specific DCP provisions are imposed in relation to future potential development particularly with regard to environmental constraints.

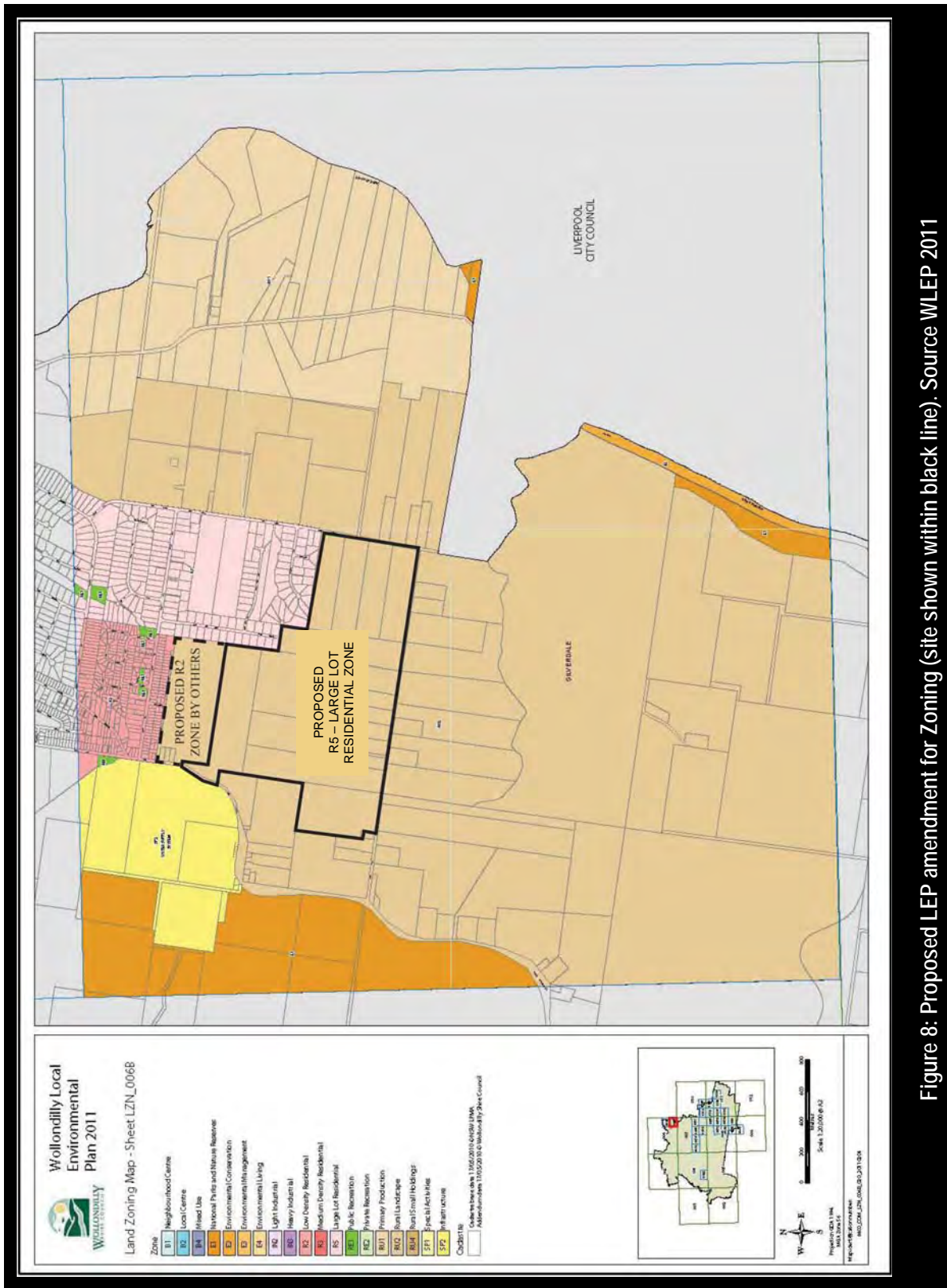

Figure 8: Proposed LEP amendment for Zoning (site shown within black line). Source WLEP 2011

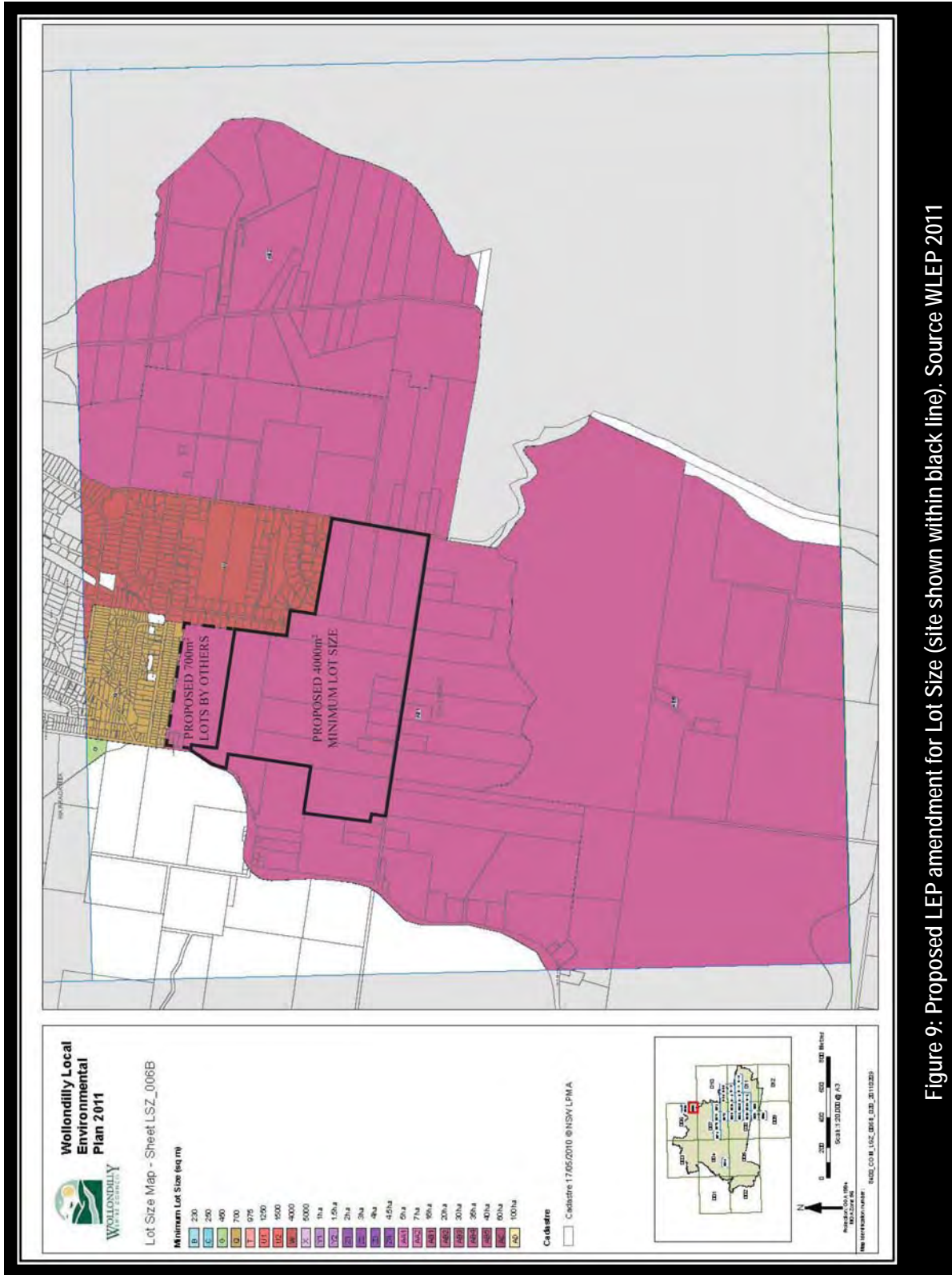

Figure 9: Proposed LEP amendment for Lot Size (site shown within black line). Source WLEP 2011



Figure 10: Proposed LEP amendment for Building Height (site shown within black line). Source WLEP 2011

3.3 Part 3 - Justification

This section sets out the justification for altering the zoning of the subject site to cater for future redevelopment.

SECTION A – Need for the Planning Proposal

1. Is the Planning Proposal a result of any study or report?

The Planning Proposal is a direct response to the Wollondilly Growth Management Strategy which was adopted by Council in 2011. The GMS was prepared by Council with the support of the NSW Department of Planning in response to increasing pressures of growth in Wollondilly and having to balance these pressures against broad community desires without a solid and up to date strategic planning platform. The GMS was prepared following an 18 month period of extensive community consultation.

Council had a new LEP (WLEP 2011) gazetted in 2011 however this planning instrument purposely did not respond to long term growth questions due to the GMS not having been finalised at the time. The GMS looks at the Shire's growth requirements for the next 20-25 years and anticipates the submission of Planning Proposals that will periodically update the LEP. We note that the subject site is identified in the Structure Plan for Silverdale and Warragamba as a "potential residential growth area".

The GMS requires that any Planning Proposal be consistent with the Key Policy Directions outlined in Section 1.6 and the Assessment Criteria contained within Appendix 1. A detailed assessment of the proposal against these requirements is undertaken in Table 4 of this Planning Proposal.

This Planning Proposal has also been prepared in conjunction with several consultants specialising in various disciplines. A series of reports accompany this Planning Proposal and their conclusions have informed a constraints mapping or "overlay mapping" exercise that identifies the areas of the subject site most suitable for future development and those that are severely constrained and may require a certain degree of protection against future development. The additional reports and constraints map are attached at Annexures A to E. Conclusions of the report are summarised in Section C and D below. The conclusions of the reports and constraints map were used to establish a conceptual Development Areas Plan to establish an understanding of the implications of site constraints on development yield (refer to Annexure F).

2. Is the Planning Proposal the best means of achieving the objectives or intended outcomes, or is there a better way?

The Planning Proposal represents the best way of achieving the Objectives or Intended Outcomes given that the proposed density of development, specifically in terms of allotment size, is not permitted under the current WLEP 2011 zoning and lot size requirements.

The Department of Planning's current position on preparing new LEPs is described in their Planning Circular No. PD06005, dated 16 February 2006 titled *Local Environmental Plan Review Panel*. The purpose of this circular is to require Councils to answer a set of pro-forma criteria when sending an LEP request to the Director General / Minister for Planning. A response to the criteria is provided in Table 2 below:

TABLE 2: LEP ASSESSMENT CRITERIA

Criteria	Response
1. <i>Will the LEP be compatible with agreed State and regional strategic direction for development in the area (e.g. land release, strategic corridors, development within 800m of a transit node)?</i>	Yes, the Planning Proposal will allow for additional rural residential allotments in an area that adjoins the existing township of Silverdale. The subject site is located within an area identified as a "potential residential growth area" under the GMS and will assist in meeting the dwelling target for Warragamba/Silverdale as stipulated in the GMS. The GMS was prepared in accordance with state and regional strategic planning documents and satisfaction of these documents is considered to be implicit in meeting the objectives of the GMS.
2. <i>Will the LEP implement studies and strategic work consistent with State and regional policies and Ministerial (s.117) directions?</i>	Yes, the Planning Proposal is consistent with the NSW Metropolitan Strategy and the dwelling targets set for the Wollondilly Shire. The proposal directly responds to key principles of the GMS for Wollondilly. In addition, the Planning Proposal is consistent with Section 117 Ministerial Directions. Refer to Table 7 for further details.
3. <i>Is the LEP located in a global/regional city, strategic centre or corridor nominated within the Metropolitan Strategy or other regional/subregional strategy?</i>	The subject site is not specifically nominated in the Metropolitan Strategy, however, the draft South West Subregional Strategy sets targets to 2031 for the Shire of 5,200 extra dwellings of which 4,000 would be from Greenfield sites. The GMS notes that Wollondilly Council has continually stated that this dwelling target is insufficient to accommodate Council's own growth forecasts and that Wollondilly needs a target of 7,000-7,500 dwellings.
4. <i>Will the LEP facilitate a permanent employment generating activity or result in a loss of employment lands?</i>	The Planning Proposal will result in the loss of only minor employment generating uses in the form of a small scale orchard, nursery and market garden, each of which are largely owner operated. The potential increase in residential population on the site is likely to increase the viability of local businesses in Silverdale and surrounding townships.
5. <i>Will the LEP be compatible/complementary with surrounding land uses?</i>	The Planning Proposal will be entirely compatible with surrounding land uses which include rural-residential (3,000m ² to 4,000m ²) lots to the north on Foxwood Close and a suburban subdivision to the north-east on St Heliers Road which will potentially be extended by the Silverdale and St Heliers Roads Planning Proposal on Lot 300. Eltons Road and Taylor's Road provide buffers to adjacent RU2 – Rural Landscape zoned land and the site is generally separated topographically to land further west. As indicated in the "Conceptual Development Area Plan" prepared by Taylor Brammer, a future road system could be integrated in a complementary manner with the existing road network.
6. <i>Is the LEP likely to create a precedent; or create or change the expectations of the landowner or other landholders?</i>	As emphasised in the preamble to the GMS, Wollondilly Shire has been subject to several Planning Proposals in recent years in a variety of locations and seeking a range of densities. It is considered that the GMS now provides a sound strategic planning basis for assessment of these proposals and therefore the context for precedent or landowner expectations has become more formalised. Whilst this may not deter Planning Proposals that are encouraged by prior Planning Proposals, it is considered that the GMS contains a rigorous method for assessing the suitability of any such proposal. Further, the GMS now identifies "potential growth areas" which further guide likely growth scenarios.
	Furthermore, the subject site is considered to have unique attributes that would distinguish it from many other sites. In particular, the site adjoins land currently used for rural residential purposes and the

	boundary to that use and density of development appears to be without planning basis. It is considered that should the current proposal be supported, a logical site boundary would be created that contains the proposed growth for a certain period of time.
7. <i>Will the LEP deal with a deferred matter in an existing LEP?</i>	No, this Planning Proposal does not deal with a deferred matter under WLEP 2011.
8. <i>Have the cumulative effects of other spot rezoning proposals in the locality been considered? What was the outcome of these considerations?</i>	As indicated, Council has recently received a Planning Proposal for adjoining land to the north of the subject site. It is considered that the combined effect of the subject proposal and that proposal represent a sound planning outcome and that they should be considered together. These two planning proposals do not conflict but rather present an opportunity for an integrated planning approach to growth in a specific contiguous area. In terms of infrastructure and servicing, the Planning Proposal has considered other Planning Proposals in Silverdale. This is further discussed in the <i>Water and Sewer Servicing Report</i> by Martens Consulting Engineers in Appendix D.

In order to allow for redevelopment of the site in an economic and orderly manner, it is considered that dealing with the request for a change to zoning and minimum allotment size is best dealt with by way of a Planning Proposal and “spot rezoning”.

Given that WLEP 2011 has only recently been prepared in accordance with the Standard Instrument Order and was gazetted, it is unlikely that a new comprehensive LEP will be prepared for some time. Council purposely took an approach to the new LEP of deferring consideration of growth questions and therefore anticipated that the objectives of the GMS would be implemented through a series of Planning Proposals.

Given the stated need for additional housing within Warragamba/Silverdale and the Sydney metropolitan region for that matter, it is considered that this Planning Proposal is the best and most efficient means of achieving the Objectives or Intended Outcomes.

3. *Is there a net community benefit?*

The NSW Department of Planning “Guide to Preparing Planning Proposals” states that the guidance on conducting a Net Community Benefit Test under the Draft Centres Policy should be followed when assessing net community benefit of a planning proposal. This guidance is more appropriate to commercial or retail development, however, the principles can be broadly applied to the current Planning Proposal and are addressed in the following table:

TABLE 3: GUIDE TO PREPARING PLANNING PROPOSALS	
Principle	Response
<i>Will the LEP be compatible with agreed State and regional strategic direction for development in the area (eg land release, strategic corridors, development within 800 metres of a transit node)?</i>	Refer to Criterion 1 in Table 2
<i>Is the LEP located in a global/regional city, strategic centre or corridor nominated within the Metropolitan Strategy or other regional/subregional strategy?</i>	Refer to Criterion 3 in Table 2
<i>Is the LEP likely to create a precedent or create or change the expectations of the landowner or other landholders?</i>	Refer to Criterion 6 in Table 2

<p><i>Have the cumulative effects of other spot rezoning proposals in the locality been considered? What was the outcome of these considerations?</i></p>	<p>Refer to Criterion 8 in Table 2</p>
<p><i>Will the LEP facilitate a permanent employment generating activity or result in a loss of employment lands?</i></p>	<p>Refer to Criterion 4 in Table 2</p>
<p><i>Will the LEP impact upon the supply of residential land and therefore housing supply and affordability?</i></p>	<p>The draft South West Subregional Strategy sets targets to 2031 for the Shire of 5,200 extra dwellings of which 4,000 would be from Greenfield sites. The GMS notes that Wollondilly Council has continually stated that this dwelling target is insufficient to accommodate Council's own growth forecasts and that Wollondilly needs a target of 7,000-7,500 dwellings. The GMS states a dwelling target for Warragamba/Silverdale of an additional 480 dwellings beyond existing zoned land to meet an overall target of 1000 dwellings by 2036. The proposal will assist with meeting this target, increasing the supply of rural residential land and most likely the affordability of this housing type.</p>
<p><i>Is the existing public infrastructure (roads, rail, utilities) capable of servicing the proposed site? Is there good pedestrian and cycling access? Is public transport currently available or is there infrastructure capacity to support future public transport?</i></p>	<p>This Planning Proposal is accompanied by a <i>Water and a Sewer Servicing Report</i> by Martens Consulting Engineers and a Traffic Impact Assessment prepared by McLaren Traffic Engineering (refer to Annexures C and D). These reports conclude that development undertaken in accordance with the proposed zoning could be adequately serviced. The subject site is approximately 900m from Silverdale Road which is on Westbus Route 795 which runs between Warragamba and Penrith. There is no impediment to the site being linked to commercial facilities in Silverdale by a cycleway in the future.</p>
<p><i>Will the proposal result in changes to the car distances travelled by customers, employees and suppliers? If so, what are the likely impacts in terms of greenhouse gas emissions, operating costs and road safety?</i></p>	<p>The subject site is served by Silverdale, Warragamba and Mulgoa townships. The proposal will not result in a significant increase in local traffic and distances to services are not excessive. As indicated above, the site also has access to public transport services.</p>
<p><i>Are there significant Government investments in infrastructure or services in the area whose patronage will be affected by the proposal? If so, what is the expected impact?</i></p>	<p>The infrastructure servicing requirements of the proposal are addressed in a <i>Water and a Sewer Servicing Report</i> by Martens Consulting Engineers and a <i>Traffic Impact Assessment</i> prepared by McLaren Traffic Engineering (refer to Annexures C and D respectively). The infrastructure and servicing needs of future development can be met and the cost of any augmentation of services would be met by the developer.</p>
<p><i>Will the proposal impact on land that the Government has identified a need to protect (e.g. land with high biodiversity values) or have other environmental impacts? Is the land constrained by environmental factors such as flooding?</i></p>	<p>The subject site is recognised as including areas of environmental sensitivity. In particular, the central part of the site is mapped as containing Shale Sandstone Transition Forest (SSTF) and Moist Shale Woodland (MSW), which are Endangered Ecological Communities (EEC), while Cumberland Plain Woodland (CPW) is listed as Critically Endangered Ecological Community (CEEC) under the NSW <i>Threatened Species Conservation Act</i> (1995). Further, CPW and SSTF are listed under the Commonwealth Environment Protection and Biodiversity Conservation Act (1999) as CEEC and EEC respectively. The land is also traversed by a watercourse. These constraints have been considered in detail in the preparation of this Planning Proposal and have lead to the preparation of a "Constraints Map" which has</p>

	informed a "Conceptual Development Areas Plan". As evidenced by these Plans, large areas of the site are unaffected by environmental constraints and the site is capable of accommodating additional residential development whilst continuing to protect these environmental attributes. Means of protection will include riparian buffers to the watercourses and conservation of large areas of protected vegetation. It may be appropriate that specific DCP controls are prepared to address these matters in a site specific manner.
<i>Will the LEP be compatible/complementary with surrounding land uses? What is the impact on amenity in the location and wider community? Will the public domain improve?</i>	Refer to Criterion 5 in Table 2.
<i>Will the proposal increase choice and competition by increasing the number of retail and commercial premises operating in the area?</i>	The proposal does not involve any commercial uses however the increased residential population will assist with supporting the ongoing viability of local commercial and retail services which currently rely on relatively low population densities compared to retail and commercial uses in more suburban localities.
<i>If a stand-alone proposal and not a centre, does the proposal have the potential to develop into a centre in the future?</i>	The proposal is not of a scale to prompt future expansion into a new centre.
<i>What are the public interest reasons for preparing the draft plan? What are the implications of not proceeding at that time?</i>	The draft South West Subregional Strategy and GMS both recognise the need for additional dwellings in the locality. The proposal responds to these targets by increasing the number of allotments in an area that abuts an existing township which provides necessary services. The WLEP 2011 has only recently been gazetted and therefore if rezoning was delayed until such time as that document is again reviewed, at least several years would pass before delivery of these additional dwellings. The State Government in recently seeking Expressions of Interest for potential housing opportunities on landowner nominated sites has reiterated the need for timely delivery of additional housing.

SECTION B – Relationship to strategic planning framework

4. Is the planning proposal consistent with the objectives and actions contained within the applicable regional or sub-regional strategy (including the Sydney Metropolitan Strategy and exhibited draft strategies)?

Metropolitan Plan for Sydney 2036

The Metropolitan Plan for Sydney 2036 contains nine subject areas, or strategies. Each strategy contains key objectives and actions. Of direct relevance to the subject Planning Proposal are strategies for "Housing Sydney's Population" and "Balancing Land Uses on the Fringe".

In terms of housing, Action D1.2 of the plan identifies 11 sub-regional areas, which together provide projections for a total of 769,000 new dwellings by 2036. The Strategy provides a target for the south-west subregion of 155,000 dwellings to 2036.

The Strategy notes the importance of protecting "fringe lands", containing Sydney's footprint, minimising environmental impacts and maintaining productive agricultural lands. Action F1.1 aims to "focus land release in Growth Centres". The Strategy notes that investigations of Macarthur South for land release were suspended in 2009 due to existing adequate stocks of land and prohibitive infrastructure costs. Given the absence of any significant agricultural capability on the subject site, it is considered that this land represents an "existing stock" suitable for residential development in a locality that is contiguous with an existing township.

The Draft South-West Central Subregional Strategy

The *Draft South-West Central Subregional Strategy* which was placed on exhibition between 24 December 2007 and 28 March 2008 provides a more detailed layer of planning considerations in relation to the broad objectives outlined in the Sydney Metropolitan Strategy. The South-west Subregion includes the LGAs of Wollondilly, Liverpool, Campbelltown and Camden.

In relation to housing, the Subregional Strategy sets a target for the south-west region of 155,500 additional dwellings by the year 2031, with the Wollondilly LGA responsible for providing 5,230 of the total dwelling target. The GMS notes that Wollondilly Council has continually stated that this dwelling target is insufficient to accommodate Council's own growth forecasts and that Wollondilly needs a target of 7,000-7,500 dwellings.

The Strategy encourages Councils to plan for sufficient zoned land to accommodate their housing target and to ensure that the location of new dwellings maintains performance against the State Plan target to increase the proportion of people living within 30 minutes by public transport of a "Strategic Centre". The planning proposal would assist with meeting Wollondilly Shire Council's housing targets of 60-70% of new housing in existing urban areas, the site being contiguous to existing low density residential development. The site is serviced by public transport in the form of a bus route along Silverdale Road which provides access to Penrith CBD in approximately 45 minutes.

5. *Is the planning proposal consistent with the local Council's Community Strategic Plan, or other local strategic plan?*

Community Strategic Plan

In July 2008 Council adopted the Community Strategic Plan 2030 (CSP). One of its purposes is to provide a focus when developing Council's other plans, such as Council's Growth Management Strategy. The CSP is based on Council's long held vision of outcomes and strategies for each of five focus areas of Community, Economy, Environment, Infrastructure and Governance. The Planning Proposal's consistency with the GMS implies satisfaction of the CSP.

Vision 2025

In 2004 Council released Vision 2025. In many ways this was an attempt to establish a growth strategy for the Shire. Previous Growth Strategies that applied to some of the towns and villages across the Shire were in fact rescinded when Council adopted Vision 2025. Council in the GMS acknowledge that, the Vision 2025 document has limitations in its ability to operate as a meaningful growth management strategy and it has never received any official recognition in that regard from the Department of Planning.

Despite its limitations as a growth management document, its key themes and directions have been carried through into the CSP and the GMS. Its specific content regarding future development scenarios for each of Wollondilly's towns and villages was reviewed to ensure that elements that are consistent with the overarching principles and directions of the GMS are captured and carried forward.

Wollondilly Shire Council – Growth Management Strategy 2011

Wollondilly Shire Council's *Growth Management Strategy 2011* is a strategic planning document that is designed to guide and inform the Council's decisions in relation to growth in the LGA. Provided in Tables 4 and 5 below is an assessment of the subject Planning Proposal against relevant considerations of the *Growth Management Strategy 2011*.

TABLE 4: GROWTH MANAGEMENT STRATEGY

Strategy Considerations	Planning Proposal Response
1.6 – Key Directions	
General Policies	
<i>P1 - All land use proposals need to be consistent with the Key Policy Directions and Assessment Criteria contained in this GMS in order to be supported by Council.</i>	Consistency with the Key Policy Directions is assessed in this Table and as assessment against Assessment Criteria (Appendix 1) is provided below in Table 5.
<i>P2 - All land use proposals need to be compatible with the concept and vision of "Rural Living"</i>	The Planning Proposal will not erode any of the nine characteristics of "rural living" contained in Part 2.7.1 of the GMS. The proposal will result in low density development in the form of minimum 4,000m ² , adjoining similar development to the north that will be designed to protect environmental features of the site. The proposal will not affect any significant areas of viable agriculture and the land can be adequately serviced by necessary infrastructure.
<i>P3 - All Council decisions on land use proposals shall consider the outcomes of community engagement.</i>	The GMS was the subject of extensive community consultation over an 18 month period. As such, it can be assumed that the GMS is a direct product of that community engagement. The subject planning proposal will be advertised/notified in accordance with Section 57 of the EP&A Act, 1979.
<i>P4 - The personal financial circumstances of landowners are not relevant planning considerations for Council in making decisions on land use proposals.</i>	Noted.
<i>P5 - Council is committed to the principle of appropriate growth for each of our towns and villages. Each of our settlements has differing characteristics and differing capacities to accommodate different levels and types of growth (due to locational attributes, infrastructure limitations, geophysical constraints, market forces etc.).</i>	The Planning Proposal relates to a site that is identified within the Silverdale and Warragamba Structure Plan as a "potential residential growth area" and will assist with meeting the dwelling target of 1,000 dwellings for Silverdale under the GMS. Accordingly, the proposal is considered to directly respond to the growth scenario envisaged by the GMS for the site.
Housing Policies	
<i>P6 - Council will plan for adequate housing to accommodate the Shire's natural growth forecast.</i>	As indicated above the proposal will assist with meeting the dwelling target for Silverdale identified in the GMS.
<i>P7 - A high growth or accelerated growth scenario is not being pursued. The extra dwellings needed for the Shire's growth therefore are not intended to accommodate the urban expansion of the Sydney Metropolitan Area*. (*It is acknowledged that Wollondilly will continue to accommodate migration from Sydney, however this is distinct from actually accommodating the spread of the Sydney urban footprint)</i>	Noted. The Planning Proposal does not seek to exceed the capacity for Silverdale (or Wollondilly) identified in the GMS.
<i>P8 - Council will support the delivery of a mix of housing types to assist housing diversity and affordability so that Wollondilly can better accommodate the housing needs of its different community members and household types.</i>	The GMS acknowledges that there is a demand for rural residential development in Wollondilly. The proposal will respond to this demand. Whilst the Planning Proposal will not directly contribute to housing affordability (primarily due to the low density proposed), it is considered that the proposed density appropriately responds to the constraints of the site and character of surrounding development.

<p><i>P9 - Dwelling densities, where possible and environmentally acceptable, should be higher in proximity to centres and lower on the edges of towns (on the "rural fringe").</i></p>	<p>The proposed RU5 zoning and minimum lot size of 4,000m² is considered to provide for an appropriate transition in density from the higher density suburban subdivision along St Heliers Road and as proposed on the site immediately to the north under a separate Planning Proposal. The proposal is therefore entirely consistent with the notion of increasing density in proximity to existing centres however lowering density at the edges.</p>
<p><i>P10 - Council will focus on the majority of new housing being located within or immediately adjacent to its existing towns and villages.</i></p>	<p>The Planning Proposal relates to a site that is identified within the Silverdale and Warragamba Structure Plan as a "potential residential growth area", which recognises its location immediately adjacent to the existing town of Silverdale.</p>
<p>Integrating Growth with Infrastructure</p>	
<p><i>P17 - Council will not support residential and employment lands growth unless increased infrastructure and servicing demands can be clearly demonstrated as being able to be delivered in a timely manner without imposing unsustainable burdens on Council or the Shire's existing and future community.</i></p>	<p>Refer to <i>Water and a Sewer Servicing Report</i> by Martens Consulting Engineers (Annexure C) which concludes that the subject site is capable of being adequately serviced. In addition, a <i>Traffic Impact Assessment</i> has been undertaken by McLaren Traffic Engineering (Annexure D) and concludes that the road network is capable of supporting the proposal.</p>
<p><i>P18 - Council will encourage sustainable growth which supports our existing towns and villages, and makes the provision of services and infrastructure more efficient and viable – this means a greater emphasis on concentrating on new housing in and around our existing population centres.</i></p>	<p>Refer to <i>Water and a Sewer Servicing Report</i> by Martens Consulting Engineers (Annexure C) which concludes that the subject site is capable of being adequately serviced. In terms of transport infrastructure, the proposal is likely to increase the viability of existing bus services in the vicinity of the site.</p>
<p><i>P19 - Dispersed population growth will be discouraged in favour of growth in, or adjacent to, existing population centres.</i></p>	<p>The Planning Proposal relates to a site that is identified within the Silverdale and Warragamba Structure Plan as a "potential residential growth area", which recognises its location immediately adjacent to the existing town of Silverdale.</p>
<p><i>P20 - The focus for population growth will be in two key growth centres, being the Picton/Thirlmere/Tahmoor Area (PTT) area and the Bargo Area. Appropriate smaller growth opportunities are identified for other towns.</i></p>	<p>The Planning Proposal relates to a site that is identified as a "smaller growth opportunity" within the Silverdale and Warragamba Structure Plan.</p>
<p>Rural and Resource Lands</p>	
<p><i>P21 - Council acknowledges and will seek to protect the special economic, environmental and cultural values of Shire's lands which comprise waterways, drinking water catchments, biodiversity, mineral resources, agricultural lands, aboriginal heritage and European rural landscapes.</i></p>	<p>This Planning Proposal has been informed by detailed analysis of site constraints. The <i>Conceptual Development Area Plan</i> prepared by Taylor Brammer Landscape Architects (Annexure F) indicates that development can take place in a manner that acknowledges and responds to these constraints, as discussed throughout this report.</p>
<p><i>P22 - Council does not support incremental growth involving increased dwelling entitlements and/or rural lands fragmentation in dispersed rural areas. Council is however committed to maintaining, where possible and practicable, existing dwelling and subdivision entitlements in rural areas.</i></p>	<p>The Planning Proposal relates to a site that is identified within the Silverdale and Warragamba Structure Plan as a "potential residential growth area", which recognises its location immediately adjacent to the existing town of Silverdale. The proposal will not result in rural land fragmentation.</p>
<p>5.3 – Distribution of Housing Numbers</p>	
<p><i>Part 5.3 identifies a total dwelling target for Warragamba/Silverdale for the GMS</i></p>	<p>We note that in addition to the "already planned" dwellings identified in the GMS, Council has received</p>

timeframe to 2036 of 1000 dwellings. Assuming the contribution of the African Lion Safari Park site (rezoned but not developed) and Draft LEP 76 (Warradale Road), the GMS assumes 520 dwellings "already planned". An additional 480 dwellings are therefore needed.

a Planning Proposal relating to the site immediately to the north of the subject site that seeks an R2 zoning that is estimated by the applicant as potentially delivering 140 additional lots. The subject proposal, based on the Conceptual Development Area Plan prepared by Taylor Brammer (Annexure F) would at a maximum deliver in the order of 193 allotments. Assuming that these four identified sites (2 referred to in the GMS and 2 above) were all developed to maximum yields, the Silverdale/Warragamba dwelling targets would still not be met. Accordingly, whilst it is acknowledged that these targets apply to a long timeframe, it is considered that the subject site provides a unique opportunity to contribute to these targets in a locality that is contiguous with existing development.

7.2 – Structure Plans

Appendix 2 to the GMS contains Structure Plans for existing townships. The subject site is located within the Silverdale & Warragamba locality. The Structure Plans include land already zoned for residential development, draft residential zonings and "potential residential growth areas". The subject site is located within a "potential residential growth area". The GMS notes that the inclusion of these lands within that category does not commit Council to supporting a planning proposal. It also notes that boundaries shown in the Structure Plans are not definitive. Rather the actual extent of developable land and the capacity and appropriate scale of development in those proposed locations is a matter for detailed analysis through the rezoning process.

It is acknowledged that the Structure Plan category of "potential residential growth area" has been shown using a conceptual graphical representation. Notwithstanding, for the reasons outlined in this Planning Proposal, it is considered that the subject site is appropriate for residential growth. In strategic planning terms, it is considered to be illogical that any growth be limited to the area immediately adjoining St Heliers Road to the north of the site. Rather it is considered appropriate to pursue a transition in density from the area immediately adjoining St Heliers Road (subject to a Planning Proposal by others for 700m² lots) to 4,000m² lots moving towards Eltons Road. This approach would allow for a reasonable transition and be consistent with the objective of lowering density "on the edges of towns" whilst increasing dwelling density within or immediately adjacent to the existing town or village. It is also noted that should development of land on the southern side of Eltons Road occur as part of the recent State Government request for land owner nominated sites for residential development, the subject site would in fact not sit at the "edge" of Silverdale.

7.3 – Assessment Criteria

Appendix 1 to the GMS contains a set of Assessment Criteria for a range of different development types. These criteria operate as checklists to ensure that each type of development meets its identified requirements.

Table 5 below provides detailed responses to the Assessment Criteria in Appendix 1, cross-referencing other parts of this Planning Proposal report where necessary.

TABLE 5: Wollondilly Growth Management Strategy 2011 – Appendix 1 Assessment Criteria

Part 1: Generic Assessment Criteria

Document/Policy/Concept	Criteria	Response
<i>State and Regional Strategies and Policies:</i>		
NSW State Plan, Metropolitan Strategy Sub-Regional Strategy	Meets objectives, sustainability criteria and directions within these documents	Refer to Section 3.3 (Part B).
State Planning Policies	Consistent with relevant State Environmental Planning Policies (SEPPs)	Refer to Table 6.
Ministerial Directions	Consistent with relevant Ministerial Directions (s.117 Directions)	Refer to Table 7.
LEP Framework	Zones and objectives in accordance with the Standard Planning Instrument LEP 2011	The proposal seeks a zone that exists under WLEP 2011 and that is consistent with the Standard Planning Instrument LEP 2011.
<i>Local Strategies and Policies:</i>		
Key Policy Directions in the GMS	Planning proposals must demonstrate that they are consistent with all relevant Key Policy Directions of the GMS	Refer to Table 4.
Precinct Planning	Planning proposals should be based on precincts containing a number of allotments which when considered as a whole will achieve the efficient and cost effective provision of infrastructure while creating minimal environmental impacts. Potential proponents of planning proposals are advised to discuss options for precinct planning with the Strategic Planning Section of Council prior to formulating their proposals.	The current planning proposal has taken an approach of including several properties, under different ownership, on the basis of establishing logical site boundaries that will effectively create a "precinct" that could be serviced by infrastructure and an integrated local road system. This integrated approach to the Planning Proposal also allows for interpretation of site constraints, particularly environmental and catchment management issues, disregarding cadastral boundaries.
Wollondilly Community Strategic Plan	<i>Wollondilly Community Strategic Plan 2030</i> – Growing Your Future details a range of criteria considered important for ensuring future growth and development in the Shire. This plan relates directly to the particular social, environmental and economic characteristics of the Shire and aims to ensure development is undertaken in a sustainable manner. Planning Proposals should meet the relevant objectives outlined in this plan.	The Planning Proposal is considered to adhere to the general principles outlined in the Community Strategic Plan, whilst the GMS provides more specific "area based" objectives and growth scenarios that the proposal is also considered to be consistent with.

<i>Project Objectives and Justification</i>	
<p><u>Overall Objective</u> The planning proposal needs to include statements explaining: - what is planned to be achieved by the Proposal; and - why a Planning Proposal is the mechanism necessary to achieve the objectives</p>	Refer to 3.1.1 and 3.1.2.
<p><u>Strategic Context</u></p> <ul style="list-style-type: none"> Is the Proposal the result of a strategic study or report endorsed by the Department of Planning and / or Wollondilly Council? If so, identify the study / strategy and explain how the Planning Proposal is in accordance with that study / strategy. 	Refer to Section 3.3 (A1).
<p><u>Net Community Benefit?</u></p> <ul style="list-style-type: none"> Demonstrate the potential for net community benefit (see Department of Planning Guidelines for a Net Community Benefit Test in the Draft Centres Policy) 	Refer to Section 3.3 (A3).
<p><u>Summary of Likely Impacts</u></p> <ul style="list-style-type: none"> What are the likely impacts to: <ul style="list-style-type: none"> the environment; the community (both the existing community and the potential new community members resulting from the proposal); the economy How are these impacts proposed to be avoided, mitigated managed and / or rehabilitated? 	Refer to Section 3.3 (C).
<p><u>Infrastructure and Services</u></p> <ul style="list-style-type: none"> Identify the type, capacity and quality / reliability of infrastructure and services: <ul style="list-style-type: none"> currently available scheduled to be available (must be confirmed in writing from service providers) (iii) needed to be available to support the proposal when operational. 	Refer to <i>Water and a Sewer Servicing Report</i> by Martens Consulting Engineers (Annexure C).
<p><u>Supply and Demand Analysis</u></p> <ul style="list-style-type: none"> A proposal shall be accompanied by an analysis of land supply and demand at both local and regional scales. The analysis must be prepared by a suitably qualified and experienced analyst and shall include independently verifiable references and sources of data used to prepare the report. The report shall include short and long term market analysis, rental availability, vacancy rates, turnover rates, duration of sale periods and population changes. 	The GMS recognises that a mix of dwelling types will be influenced by the realities and demands of the housing market and would be best left to subdivision and the DA stage. The GMS states that it is reasonable to assume that there will always be a market for the type of housing proposed. Well located rural residential properties will deliver significant positive outcomes.
<p><u>Site suitability / attributes</u></p> <ul style="list-style-type: none"> A proposal shall demonstrate using independently verifiable evidence that the site selected is the best available site to accommodate the proposed use in a local and regional context. Reasons may include, but not be limited to; consolidated site area, access advantages, utilities and other infrastructure available, fewer constraints, potential for linkages and integration with other land uses to a mutually beneficial outcome 	The site has been identified by the GMS as being a "potential residential growth area". The site is therefore considered one of several specifically identified sites that through the GMS process were considered the best available to accommodate local growth. This Planning Proposal has further analysed site constraints and the

	suitability of the site for development.
Preserving Rural Land and Character	
<u>Character and Setting</u>	
<ul style="list-style-type: none"> A proposal must demonstrate how it will contribute to maintaining rural character, including how it will be consistent with the definition of Rural Living contained in this GMS 	The Planning Proposal will not erode any of the nine characteristics of "rural living" contained in Part 2.7.1 of the GMS. The proposal will result in low density development in the form of minimum 4,000m ² lots, adjoining similar development to the north, which will be designed to protect environmental features of the site. The proposal will not affect any significant areas of viable agriculture and the land can be adequately serviced by necessary infrastructure.
<u>Visual attributes</u>	
<ul style="list-style-type: none"> A proposal must create or maintain visual catchment boundaries which define the rural-urban interface. A proposal must maintain rural landscape character. A proposal must ensure future development is located and able to be designed so as to not impact on visually sensitive ridgelines or areas of topographical or visual significance or significant view corridors. A proposal must ensure that it will have a minimal impact on riverine scenic quality. 	It is considered that the site boundaries provide for a logical visual catchment boundary between suburban and rural residential living areas and the existing RU2 zone to the east, south and west. To the west the site is bound by higher land that then falls towards the Sydney Drinking Water Catchment and to the south and east the site is bound by roadways that will provide a physical distinction between the rural-urban interface (noting that the proposal will result in rural residential lots that will act as a transition to the more urban densities to the north). The subject site is not in an area or situated at a topographic level that makes it highly visible from any significant vantage points in the local area.
<u>Rural and Resource Lands</u>	
<ul style="list-style-type: none"> Where relevant proposals should include an assessment of the potential viability of agricultural use of the land in accordance with recognised guidelines (such as Department of Agriculture Site Suitability Assessments). This assessment needs to demonstrate that the site cannot reasonably be considered suitable as a viable agricultural holding (neither presently nor in the future). Proposals need to demonstrate that the future use of the land as proposed will not eliminate or restrict opportunities for continued or new agricultural uses on adjoining and nearby land 	In consultation with the Department of Primary Industries, classification of the subject site was determined to be Class 3, under the Agricultural Land Classification. Class 3 is land generally suited to grazing and cropping, but not continuous cultivation. It is generally of moderate agricultural significance. The subject site does not presently contain any major/intensive agricultural uses and rural uses are generally limited to hobby farming and low intensity cropping, generally along Eltons Road. It is not expected to intensify in the future, due to the smaller land holdings within the subject site and potential environmental concerns found within Class 3 land such as minor erosion and soil structure breakdown which could potentially limit the remaining low-scale agricultural uses. Surrounding land

	adjoining the subject site has land classifications which vary from 4 to 13, which therefore have less viability for agricultural uses at present and in the future.
Environmental Sustainability	
<u>Protection and conservation</u>	Environmental attributes of the site have been considered in detail in the <i>Ecology and Bushfire Report</i> prepared by Ecological Australia (Annexure A). The Constraints Mapping submitted with this Planning Proposal summarises these environmental constraints (Annexure E). The Conceptual Development Area Plan identifies a potential response to these environmental constraints (Annexure F). As indicated elsewhere in this Report it may be appropriate that site specific provisions be included in a DCP to address environmental protection.
<ul style="list-style-type: none"> Proposals should demonstrate how future development shall allow for the protection of threatened species, populations or ecological communities and their habitats. Proposals should not require the removal of significant tracts of remnant vegetation and should enable the retention and conservation of environmentally significant land and riparian lands. The protection, rehabilitation and management of environmentally significant lands and riparian lands should not negatively impact on the ownership, care, control and management responsibilities of Council in the short or long term. 	
<u>Water Quality and Quantity</u>	Refer to <i>Water and a Sewer Servicing Report</i> by Martens Consulting Engineers and <i>Ecology and Bushfire Constraints Report</i> by Ecological Australia (Annexures C and A, respectively).
<ul style="list-style-type: none"> Proposals should provide buffer zones to protect watercourses and provide riparian lands setbacks. Proposals should ensure that any future development in the drinking water catchment can meet the neutral or beneficial effect on water quality (NorBE) test, consistent with the <i>Drinking Water Catchments State Environmental Planning Policy</i>. Proposals must give consideration to Sydney Catchment Authority's Strategic Land and Water Capability Assessments (SLWCA) to avoid risk to water quality. Proposals must demonstrate future development will protect groundwater resources and groundwater dependent ecosystems. Proposals should include statements outlining: <ul style="list-style-type: none"> - Demand for water to the site - commitments to collect water on site - commitments to reuse water on site - Production of wastewater and its treatment and disposal methods. Proposals must note lead to proliferation of basic Landholder Rights along the frontage of waterways or over any vulnerable aquifers. 	
<u>Flood Hazard</u>	Refer to <i>Water and a Sewer Servicing Report</i> by Martens Consulting Engineers (Annexure C).
<u>Geotechnical/Resources/Subsidence</u>	Preliminary investigations indicate that the site is not subject to subsidence or any geotechnical constraints. The site is not in a mine subsidence area and will not sterilise
<ul style="list-style-type: none"> Land to be developed must not be located in an area of low or medium risk of slope instability. Planning proposals should not sterilise access to coal resources or access to existing infrastructure associated with 	

<p>approved mining uses and this must be verified in writing from the appropriate government authority.</p> <ul style="list-style-type: none"> • Planning proposals should indicate whether the land is located outside of a Mine Subsidence area or whether coal resources have been extracted and the impacts of subsidence completed. 	<p>access to any known coal reserves.</p>
<p><u>Buffers and Spatial Separation</u></p> <ul style="list-style-type: none"> • Adequate buffers shall be provided within the site to achieve separation between the proposed uses and any adjacent incompatible development as required. • Proposals should provide buffer zones to protect watercourses and provide riparian lands setbacks as required. 	<p>Given the proposed minimum lot sizes, it is considered that future development will be capable of being sited so as to provide large buffers to surrounding development. In any case, the proposal retains residential use of the site albeit at a higher density and therefore will not introduce a new incompatible development type. Buffer zones to protect watercourses and provide riparian lands have been considered in Constraints Mapping undertaken for this Planning Proposal. Given the proposed minimum lot sizes of 4,000m² it is considered that future development will be capable of being designed in a manner that protects the environmental attributes of the site.</p>
<p><u>Bushfire Hazard</u></p> <ul style="list-style-type: none"> • Where the site is identified as Bushfire Prone land in Council's records the planning proposal should be able to provide appropriate protection and evacuation measures, including Asset Protection Zones and perimeter roads to avoid risk to human life. • All bush fire hazard reduction measures and Asset Protection Zones shall be contained within the site. • Asset Protection Zones and other measures for bushfire hazard management must be located outside areas identified as environmentally sensitive land including habitat and riparian areas to mitigate impact on ecological functioning. 	<p>Refer to <i>Ecology and Bushfire Report</i> by Eco Logical Australia (Annexure A).</p>
<p><u>Heritage</u></p> <ul style="list-style-type: none"> • Proposals must demonstrate no detrimental impacts to any item or place of Aboriginal or archaeological significance or on any heritage item or heritage conservation area. 	<p>Refer to <i>Aboriginal Heritage and Non-Indigenous Heritage Assessment Report</i> by Artefact (Appendix B).</p>
<p><u>Resource Sustainability</u></p> <ul style="list-style-type: none"> • Proposals should demonstrate commitment to maximising opportunities for energy efficiency, water recycling and reuse and waste minimisation 	<p>The environmental constraints of the site have been mapped and it has been demonstrated in the Conceptual Development Areas Plan that future development is capable of protecting these attributes (Annexure F). Sustainability measures on a subdivision and individual lot basis can be further pursued at development application stage.</p>
<p>Infrastructure</p>	
<p><u>Efficient Use and Provision of Infrastructure</u></p> <ul style="list-style-type: none"> • Proposals for urban land uses (industrial, commercial, residential) shall demonstrate minimum provisions (where appropriate) of: 	<p>Refer to <i>Water and a Sewer Servicing Report</i> by Martens Consulting Engineers (Annexure C). Finer detail on matters such as street trees, footpaths, street lighting and</p>

<ul style="list-style-type: none"> - electricity - reticulated water - reticulated sewer - telephone services - optic fibre - public roads integrated with the existing public road network - kerb and gutter and stormwater management infrastructure - footpaths suitable for pedestrian use - shared pathways compatible with an adopted Council strategy - street lighting to Australian Standards - public open space in accordance with best practice design guidelines adopted strategies - bus stops - street trees - contributions towards community services and facilities as may be required adopted strategy and works schedules 	<p>stormwater infrastructure will be addressed at subdivision stage.</p>
<p><u>Transport, Roads and Access</u></p> <ul style="list-style-type: none"> • Proposals must demonstrate (where possible) a commitment to improving access and movement opportunities to and through the site by means other than private cars. • Proposals must demonstrate a commitment to ensuring the local road network is capable of catering for future development in terms of road capacity, traffic management and safety. • Proposals shall allow for the acquisition, dedication and/or construction of future local or regional road links as identified in state or local environmental planning instruments. • Proposals should minimise new vehicle access points directly to a major regional or arterial road. 	<p>In addition, <i>Traffic Impact Assessment</i> has been undertaken by McLaren Traffic Engineering (Annexure D) and concludes that the road network is capable of supporting the proposal.</p>
<p><u>Open Space</u></p> <ul style="list-style-type: none"> • Proposals should identify opportunities within the site for creating a variety of types of public open space and / or improving the quality of public open space in the locality. • Provision and design standards for public open space shall be demonstrated to be consistent with best practice guidelines and adopted strategies and plans. • Proposals should include provision of access connections to existing or planned shared pathways. 	<p>The Planning Proposal includes a Conceptual Development Area Plan (Annexure F) that identifies a potential approach to future development of the subject site. It is anticipated that in responding to site constraints, riparian corridors will be provided and parts of the site may require being set aside to protect significant vegetation. The ability to provide public access links across the site would be further investigated at subdivision stage.</p>
<p>Part 3: Residential Lands</p>	
<p><u>Location/Area/Type</u></p> <ul style="list-style-type: none"> • Planning proposals should be consistent with land identified under the relevant LEP or the GMS for rural-residential, medium density development or town edge development. • The planning proposal shall demonstrate how the new site will be integrated with adjacent lands and provide opportunity for effective links to other land uses (particularly town and village centres and public open spaces) and 	<p>The site has been identified by the GMS as being a "potential residential growth area". The Conceptual Development Area Plan prepared by Taylor Brammer Landscape Architects (Annexure F) identifies a conceptual development scenario including a spine road network. It is</p>

<p>make efficient use of existing and / or new infrastructure , services and facilities</p> <ul style="list-style-type: none"> The site shall be of sufficient area to accommodate a range of lot sizes, the provision of public roads, pathways and public open space and other features including buffers / setbacks. 	<p>considered that this plan demonstrates the way in which future development would be connected with the surrounding area. The proposed lot size of minimum 4,000m² will allow for provision of buffers to surrounding development. Whilst this minimum lot size is proposed, future development may include a range of lot sizes.</p>
<p><u>Social Integration</u></p> <ul style="list-style-type: none"> Gated communities are not acceptable in Wollondilly Shire. The proposal shall commit to achieving a variety of housing forms to increase the potential for a mix of household types and diversity amongst residents. Emphasis shall be placed on providing high quality public spaces within the site (such as streets, pathways, footpaths and open space) to provide attractive places for people to use and opportunities for informal social interaction. 	<p>The future development of the site will not be in the form of a gated community. The likely future development type or rural residential allotments has been identified by the GMS as being an attractive and sought after living option within the Wollondilly Shire. The site provides opportunities for provision of open space and riparian corridors that may, subject to future consideration and design, enhance the extent of public and recreational space in the Shire.</p>
<p><u>Additional Criteria for Specific Land Uses</u> <u>Rural Residential:</u></p> <ul style="list-style-type: none"> The site shall be contiguous to the town edge. The furthest parts of the site should be located within approx. 2 km of the nearest existing town or village centre. The proposal should create and maintain a distinct town edge setting and an effective interface between urban and rural land. The proposal should include a total water cycle management plan including concept details of on-site sewage management and stormwater management integrated with the natural catchment. 	<p>The subject site is contiguous to the edge of Silverdale.</p> <p>Silverdale does not have a large town or village centre, rather it is generally served by a relatively modern small scale shopping centre, approximately 2.3km to the north of the geographic centre of Silverdale. The furthest sections of the subject site are presently 3.7km (approx) from the small centre. The distance from services is not vastly different from existing residential development in Silverdale. The proposal will assist with economic viability of this commercial offering and may encourage amplification of local services.</p> <p>The proposal provides a transition from suburban allotments along St Heliers Road to the north to RU2 zoned land to the south. The site is physically bound by roadways and the edge of a water catchment and therefore provides a distinct town edge condition.</p> <p>Refer to <i>Water and a Sewer Servicing Report</i> by Martens Consulting Engineers (Annexure C).</p>

<ul style="list-style-type: none"> • The proposal must preserve the separation between urban areas. • The proposal must preserve rural character ("look and feel"). • Rural residential lots are expected to be mixed with "urban on town edge" developments to broaden housing mix and affordability and achieve overall efficient residential densities. • The subdivision should not lead to proliferation of Basic Landholder Rights along the frontage of waterways or over any vulnerable aquifers. • The proposal shall be serviced by reticulated town water or it should demonstrate that it has an adequate and self sufficient water supply without having to pump it from streams. 	<p>The proposal provides for a logical extension of the existing Silverdale township and does not erode separation to other urban areas.</p> <p>The proposed 4,000m² minimum lot size will preserve a rural character allowing for retention of vast areas of vegetation, a low density of built form and opportunities for use of open space areas for "semi-rural" activities.</p> <p>The proposed rural residential lots will adjoin a suburban style subdivision to the north and therefore in combination provide a broad housing/lot type mix at the edge of Silverdale.</p> <p>The site does not front any waterway and is not situated over any vulnerable aquifers.</p> <p>Refer to <i>Water and a Sewer Servicing Report</i> by Martens Consulting Engineers (Annexure C).</p>
<p><u>Urban on Town Edge</u></p> <ul style="list-style-type: none"> • The site shall be contiguous to existing urban land. • The site should be located within practical walking distance of existing town, village or neighbourhood centre. • The proposal needs to demonstrate that residential use of the land is the most suitable use of the land within the context of land uses in the area. • The proposal should achieve physical and visual integration with the existing edge of town • Proposals should include a mix of residential lot sizes and cater for a mix of housing types to assist diversity and affordability. • Proposals should complement existing residential areas in terms of subdivision layout and housing design, density and character. • Proposals should achieve an average density of 11 to 16 dwellings per hectare. • Proposals should provide a visually attractive transition between urban and rural areas. • Proposals must be capable of being serviced by reticulated water and sewerage schemes such as Sydney Water infrastructure or package treatment plant systems. • Proposals should enable or include connection to existing shared pathway networks. • Proposal should incorporate community land and proposals for development of facilities and services if demand on existing social and community services provisions is likely to be 	<p>The proposal is for rural-residential density development rather than "urban" housing. The proposal provides a transition from "urban on town edge" development along St Heliers Road to RU2 land south, east and west of the site.</p>

<p><u><i>Self-contained Master Planned Estates</i></u></p> <ul style="list-style-type: none">• NOTE: Applies to proposals to develop large masterplanned residential subdivisions.• Proposals must be located immediately adjacent to existing towns & villages so all of the criteria applying under the heading Urban on Town Edge category above also apply.• Proposals should provide an overall master plan displaying – good design, sensible overall structure, open space facilities, environmental protection, shared pathway networks, etc.• Proposals should be supported by evidence that a new estate will not be detrimental to the viability and hierarchy of existing towns and villages• Public access must be provided throughout roads, pathways and public open spaces of the estate area (gated Communities are not acceptable).	<p>The proposal does not fit within this category of development.</p>
---	---

6. Is the planning proposal consistent with applicable state environmental planning policies?

There are no State Environmental Planning Policies (SEPPs) or known Draft SEPPs that would prohibit or restrict the planning proposal. An assessment against relevant SEPPs is provided below (note SEPPs that are not relevant to the proposal have not been included in the table):

TABLE 6: RELEVANT STATE ENVIRONMENTAL PLANNING POLICIES			
SEPP	Relevance	Consistency	Comments
SEPP No 55-Remediation of Land	Introduces state-wide planning controls for the remediation of contaminated land.	Yes	It is considered appropriate that assessment of potential contamination be undertaken at the development application stage for any future subdivision. Based on the site history, it would appear unlikely that the site could not be made fit for residential occupation.
SEPP (Building Sustainability Index: BASIX) 2004	This SEPP operates in conjunction with Environmental Planning and Assessment Amendment (Building Sustainability Index: BASIX) Regulation 2004 to ensure the effective introduction of BASIX in NSW. The SEPP ensures consistency in the implementation of BASIX throughout the State by overriding competing provisions in other environmental planning instruments and development control plans, and specifying that SEPP 1 does not apply in relation to any development standard arising under BASIX. The draft SEPP was exhibited together with draft Regulation amendment in 2004.	Yes	Compliance with BASIX would be achieved under future development / project applications for the construction of dwellings on the site. There are no constraints on the site that would preclude compliance with the SEPP.
State Environmental Planning Policy (Sydney Drinking Water Catchment) 2011		N/A	Sheet 6 of the SEPP (Sydney Drinking Water Catchment) 2011 mapping set shows that the subject site is west of the area affected by the SEPP. The boundary to the catchment essentially follows Silverdale Road

7. Is the planning proposal consistent with applicable Ministerial Directions (s.117 directions)?

The proposal is consistent with all applicable Ministerial Directions under Section 117 of the Environmental Planning & Assessment Act, 1979. An assessment against the applicable directions is provided in the following table:

TABLE 7: S.117 MINISTERIAL DIRECTIONS

Ministerial Direction	Relevance	Consistency	Implications
1. Employment and Resources			
1.2 Rural Zones	<p>A Planning Proposal must not rezone land from rural to residential or increase the permissible density of land within a rural zone. However, a Planning Proposal may be inconsistent with such terms, provided that:</p> <p>It is justified by a strategy which:</p> <ul style="list-style-type: none"> • Gives consideration to the objective of the direction; • it identifies the land subject to the Planning Proposal; and • is approved by DG of the Department of Planning; <p>OR it is justified by:</p> <ul style="list-style-type: none"> • A study prepared in conjunction with the Planning Proposal which gives consideration to the objectives of the direction; or • In accordance with the relevant subregional strategy; or • Is of minor significance. 	Yes	<p>As previously described, the Planning Proposal is entirely consistent with the Wollondilly GMS in that the Strategy identifies the site as being within a "potential residential growth area". The proposal will assist with meeting dwelling targets for Silverdale/ Warragamba which are driven by the Metropolitan Strategy and Sub-Regional Strategy. The Planning Proposal has been prepared following detailed site investigations which have concluded that the site is suitable for future rural residential development. Whilst the site contains some small scale rural land uses, these uses can be best described as hobby style farming operations and do not provide significant levels of production. Accordingly, the proposal is considered with this Ministerial Direction.</p>
2. Environment and Heritage			
2.1 Environment Protection Zones	<p>A planning proposal must include provisions that facilitate the protection and conservation of environmentally sensitive areas.</p> <p>A planning proposal that applies to land within an environment protection zone or land otherwise identified for environment protection purposes in a LEP must not reduce the environmental protection standards that apply to the land (including by modifying development standards that apply to the land). This requirement does not apply to a change to a development standard for minimum lot size for a dwelling in accordance with clause (5) of Direction 1.5 "Rural Lands".</p> <p>A planning proposal may be inconsistent with the terms of this direction only if the relevant planning authority can satisfy the Director-General of the Department of Planning (or an officer of the Department nominated by the Director-General) that the provisions</p>	Yes	<p>The subject site is identified as "sensitive land" on the Natural Resources—Water Map under WLEP 2011 and has been identified as containing Shale Sandstone Transition Forest (SSTF), Moist Shale Woodland (MSW) and Cumberland Plain Woodland (CPW). The land is not identified in an "environment protection zone" as such. These matters have been considered in detail in <i>Ecology and Bushfire Constraints Report</i> by Eco Logical Australia (Annexure A) and a Conceptual Development Areas Plan has been prepared by Taylor Brammer (Annexure F) to establish the impacts of these constraints on development potential of the land. It is considered that on the basis of these conclusions, future development could proceed in a manner that protects and conserves environmentally sensitive areas. If considered necessary, site specific DCP provisions could be established to assist with guiding future development.</p> <p>Whilst Local Planning Direction 1.5 does not apply to Wollondilly, we note the reference to Direction 2.1 not applying to a change of development standard for minimum lot size.</p> <p>Further, any future development applications would be assessed under WLEP</p>

	<p>of the planning proposal that are inconsistent are:</p> <p>a. justified by a strategy which:</p> <p>i.gives consideration to the objectives of this direction,</p> <p>ii.identifies the land which is the subject of the planning proposal (if the planning proposal relates to a particular site or sites), and</p> <p>iii.is approved by the Director-General of the Department of Planning, or</p> <p>(b) justified by a study prepared in support of the planning proposal which gives consideration to the objectives of this direction, or</p> <p>(c) in accordance with the relevant Regional Strategy or Sub-Regional Strategy prepared by the Department of Planning which gives consideration to the objective of this direction, or</p> <p>(d) is of minor significance.</p>	<p>2011 and Clauses 7.2 and 7.3 require assessment of environment protection matters.</p>
<p>2.3 Heritage Conservation</p>	<p>(1) A planning proposal must contain provisions that facilitate the conservation of:</p> <p>(a) items, places, buildings, works, relics, moveable objects or precincts of environmental heritage significance to an area, in relation to the historical, scientific, cultural, social, archaeological, architectural, natural or aesthetic value of the item, area, object or place, identified in a study of the environmental heritage of the area,</p> <p>(b) Aboriginal objects or Aboriginal places that are protected under the <i>National Parks and Wildlife Act 1974</i>, and</p> <p>(c) Aboriginal areas, Aboriginal objects, Aboriginal places or landscapes identified by an Aboriginal heritage survey prepared by or on behalf of an Aboriginal Land Council, Aboriginal body or public authority and provided to the relevant planning authority, which identifies the area, object, place or landscape as being of heritage significance to Aboriginal culture and people.</p> <p>(2) A planning proposal may be inconsistent with the terms of this direction only if the relevant planning authority can satisfy the Director-General of the Department of Planning (or an officer</p>	<p>The subject site contains no listed heritage items of aboriginal, archaeological, landscape or general heritage and is not within a conservation area. Notwithstanding, given the locality and nature of the subject site, an <i>Aboriginal Heritage Due Diligence Assessment and Preliminary Non-Indigenous Heritage Assessment</i> of the site has been undertaken to identify any possible constraints on future development of the site. This assessment concludes in relation to non-indigenous heritage that:</p> <p>"</p> <ul style="list-style-type: none"> • <i>There are no non-Indigenous heritage listed sites within the study area;</i> • <i>Two heritage listed sites within the vicinity of the study area will not be impacted by the proposed rezoning;</i> • <i>There is a low potential for non-Indigenous archaeological remains to be present within the study area.</i> <p><i>It is therefore recommended that:</i></p> <ul style="list-style-type: none"> • <i>There are no know non-Indigenous heritage constraints within the study area;</i> • <i>Further non-Indigenous heritage assessment or Statements of Heritage Impacts are not recommended;</i>

- of the Department nominated by the Director-General) that:
- (a) the environmental or indigenous heritage significance of the item, area, object or place is conserved by existing or draft environmental planning instruments, legislation, or regulations that apply to the land, or
 - (b) the provisions of the planning proposal that are inconsistent are of minor significance.

- *If unanticipated non-Indigenous heritage items or archaeological remains are identified within the study area, further assessment will be required to determine heritage significance."*

In relation to aboriginal heritage their report concludes that:

- "
- *There are no recorded Aboriginal sites within the study area;*
 - *The central portion of the study area has been assessed as having a moderate archaeological potential.*

It is therefore recommended that:

- *A further Aboriginal heritage assessment shall be prepared at development application stage for subdivision of the site covering the sections of the study area that have been assessed as having a moderate archaeological potential;*
- *There are no known Aboriginal heritage constraints on sections of the study area assessed as having a low archaeological potential and therefore no further Aboriginal archaeological work will be required in these areas;*
- *If unanticipated Aboriginal objects are located within the areas of low potential during future works further archaeological investigation and consents may be required;*
- *A copy of the Due Diligence Assessment should be forwarded to TLALC and CBNTCC for their comments."*

Future development applications will be considered under WLEP 2011 and Clause 5.10 requires assessment of impacts on heritage.

3.Housing,Infrastructure and Urban Development

3.1 Residential Zones	<p>A planning proposal must include provisions that encourage the provision of housing that will:</p> <ul style="list-style-type: none"> • broaden the choice of building types and locations available in the housing market, and • make more efficient use of existing infrastructure and services, and • reduce the consumption of land for housing and 	Yes	<p>The proposal will provide the opportunity for provision of additional rural residential housing in Wollondilly which has been identified in the GMS as being in demand. Therefore, the Planning Proposal responds directly to the needs of the local housing market. The subject site incorporates several allotments that are currently being used for rural residential living albeit at a very low density. The proposal will enable a similar form of residential living but will make more efficient use of the land and existing services. The Planning Proposal will</p>
-----------------------	---	-----	--

	<p>associated urban development on the urban fringe, and</p> <ul style="list-style-type: none"> • be of good design. <p>A planning proposal must, in relation to land to which this direction applies:</p> <ul style="list-style-type: none"> • contain a requirement that residential development is not permitted until land is adequately serviced (or arrangements satisfactory to the council, or other appropriate authority, have been made to service it), and • not contain provisions which will reduce the permissible residential density of land. 		<p>thereby be effectively reducing the consumption of land for residential living by decreasing lot sizes and increasing the number of allotments in a locality that is already being used for rural residential purposes.</p> <p>The land can adequately serviced, or services can be amplified, so as to enable immediate development for the purposes proposed.</p>
3.4 Integrating Land Use and Transport	<p>A planning proposal must locate zones for urban purposes and include provisions that give effect to and are consistent with the aims, objectives and principles of:</p> <p>(1) <i>Improving Transport Choice – Guidelines for planning and development</i> (DUAP 2001), and</p> <p>(2) <i>The Right Place for Business and Services – Planning Policy</i> (DUAP 2001).</p>	Yes	<p>The subject site adjoins an established residential area and is served by a bus route along Silverdale Road which links with larger regional centres of Penrith and Campbelltown. Accordingly, the planning proposal is considered to be consistent with the aims and objectives of these documents.</p>
4. Hazard and Risk			
4.1 Acid Sulphate Soils	<p>A Planning Proposal must consider the environmental impacts of Acid Sulfate Soils.</p>	Yes	<p>The site is not constrained by Acid Sulfate Soils such that would preclude future residential development.</p>
4.3 Flood Prone Land	<p>A Planning Proposal must include provisions that give effect to and are consistent with the <i>NSW Flood Prone Land Policy</i> and the principles of the <i>Floodplain Development Manual</i>.</p>	Yes	<p>These provisions will be considered in any future development applications, however flooding is not considered to be a constraint that would preclude development.</p>
4.4 Planning for Bushfire Protection	<p>A Planning Proposal must:</p> <ul style="list-style-type: none"> • Have regard for the Planning for Bushfire Protection 2006; • Introduce controls that avoid placing inappropriate developments in hazardous zones; and • Ensure that bushfire hazard reduction is not prohibited within the APZ. 	Yes	<p>An assessment of bushfire conditions in accordance with the requirements of <i>Planning for Bushfire Protection</i> has been completed by Ecological and is submitted with this Planning Proposal. Ecological has considered the Conceptual Development Area Plan prepared by Taylor Brammer Landscape Architects and has provided advice that development of future subdivided allotments could be designed in a manner that could meet <i>Planning for Bushfire Protection</i>.</p>

3.4 Where this direction applies

- (3) This direction applies to land shown within the boundaries of the proposed airport site and within the 20 ANEF contour as shown on the map entitled "Badgerys Creek–Australian Noise Exposure Forecast–Proposed Alignment–Worst Case Assumptions", this being found in Appendix U of the Second Sydney Airport Site Selection Program Draft Environmental Impact Statement within Fairfield City Council, Liverpool City Council, Penrith City Council and Wollondilly Shire Council local government areas.

Undetermined

Despite requests to Wollondilly Shire Council and the Department of Planning and Infrastructure, Noise Exposure mapping was unable to be obtained. However, as the site adjoins existing residential uses within the Silverdale Township, it is assumed that potential acoustic impacts can be dealt with through specific construction methods.

3.5 What a relevant planning authority must do if this direction applies

- (4) Planning proposals must not contain provisions that enable the carrying out of development, either with or without development consent, which at the date of this direction, could hinder the potential for development of a Second Sydney Airport.

3.6 Consistency

- (5) A planning proposal may be inconsistent with the terms of this direction only if the relevant planning authority can satisfy the Director-General of the Department of Planning (or an officer of the Department nominated by the Director-General) that the provisions of the planning proposal that are inconsistent with the terms of this direction are:
- (a) justified by a strategy which:
 - (i) gives consideration to the objectives of this direction, and
 - (ii) identifies the land which is the subject of the planning proposal (if the planning proposal relates to a particular site or sites), and

- (iii) is approved by the Director-General of the Department of Planning, or
- (b) justified by a study prepared in support of the planning proposal which gives consideration to the objective of this direction, or
- (c) in accordance with the relevant Regional Strategy or Sub-Regional Strategy prepared by the Department of Planning which gives consideration to the objective of this direction, or
- (d) of minor significance.
- (e)

6. Local Plan Making

6.1 Approval and Referral Requirements	<p>A planning proposal must:</p> <ul style="list-style-type: none"> • minimise the inclusion of provisions that require the concurrence, consultation or referral of development applications to a Minister or public authority, • not identify development as designated development unless the relevant planning authority has obtained the approval of the Director-General of the Department of Planning 	Yes	The Planning Proposal does not introduce any additional concurrence requirements or identify the development as designated development.
6.3 Site Specific Provisions	<p>A planning proposal that will amend another environmental planning instrument in order to allow a particular development proposal to be carried out must either:</p> <ul style="list-style-type: none"> (a) allow that land use to be carried out in the zone the land is situated on, or (b) rezone the site to an existing zone already applying in the environmental planning instrument that allows that land use without imposing any development standards or requirements in addition to those already contained in that zone, or (c) allow that land use on the relevant land without imposing any development standards or requirements in addition to those already contained in the principal environmental planning instrument being amended. <p>A Planning Proposal must not contain or refer to drawings that show details of the development proposal.</p>	Yes	<p>The preferred option for achieving the Objectives or Intended Outcomes stated in Part 1 is to rezone the subject site to the R5 – Large Lot Residential zoning under WLEP 2011. This would enable development of the site for the purposes proposed under an existing zone and would not impose any additional development standards or requirements on development.</p> <p>It is not intended to refer to any drawings with the LEP that show details of the development. The Conceptual Development Areas Plan has been provided for information purposes only as a visual representation of the site constraints and possible future proposed development.</p>

7. Metropolitan Planning

7.1 Implementation of the Metropolitan Strategy	Planning proposals shall be consistent with the Metropolitan Strategy: City of Cities, A Plan for Sydney's Future	Yes	The draft South West Subregional Strategy sets targets to 2031 for the Shire of 5,200 extra dwellings of which 4,000 would be from Greenfield sites. The GMS notes that Wollondilly Council has continually stated that this dwelling target is insufficient to accommodate Council's own growth forecasts and that Wollondilly needs a target of 7,000-7,500 dwellings. The GMS states a dwelling target for Warragamba/Silverdale of an additional 480 dwellings beyond existing zoned land to meet an overall target of 1000 dwellings by 2036. The proposal will assist with meeting this target, increasing the supply of rural residential land and most likely the affordability of this housing type.
---	---	-----	---

SECTION C – Environmental, Social and Economic Impact

8. *Is there any likelihood that critical habitat or threatened species, populations or ecological communities, or their habitats, will be adversely affected as a result of the proposal?*

A combined *Ecology and Bushfire Constraints Report* is provided at Annexure A of this report. This report concludes the following with respect to specific environmental issues:

“ **Ecology**

A large, relatively intact stand of SSTF vegetation runs through the centre of the subject site. Several smaller stands of SSTF and CPW vegetation are also spread across the site. The majority of vegetation remaining on site is in a good condition with a moderate to high recovery potential. Both vegetation communities are designated as Endangered or Critically Endangered Ecological Communities under both the NSW TSC Act and Commonwealth EPBC Act. Any proposal that would negatively impact on this vegetation will require an assessment of the significance of that impact under both the TSC and EPBC Acts.

The current Conceptual Development Areas Plan (Figure 6) shows the central stand of SSTF vegetation on the site as not proposed for future subdivision / development. This vegetation should be retained and enhanced, which will also increase its value as a link between adjacent larger areas of good quality vegetation and improve regional connectivity. Maintaining this large stand of vegetation in one ownership should ensure better conservation outcomes and enable positive biodiversity outcomes to be explored such as securing this area as an offset site for development impacts resulting from eventual subdivision and residential development activity on the remainder of the site. This area also has potential to become registered biobank site which would provide for in-perpetuity protection and management of the vegetation on site. The smaller, isolated areas of SSTF and CPW on site could largely be retained through the appropriate subdivision design and approval of suitable building envelopes with future subdivision applications. The use of minimum 4000 ha allotments should ensure that where small stands of this vegetation occurs, adequate building envelopes (including bushfire APZs) can be provided which do not conflict with the goal of maintaining and enhancing the condition and extent of these endangered ecological communities. Innovative urban design solutions such as cluster housing could also improve ecological outcomes by focussing urban development in the most suitable parts of the site – i.e. areas with lowest ecological value, which will generally also correspond to areas with lowest bushfire threat and exposure.

Riparian

The use of 4000sqm minimum lot sizes should enable sufficient land to be available for the erection of a dwelling outside these sensitive lands as well as the maintenance and protection of a functioning, intact riparian corridor. This can be further ensured at subdivision stage through the approval of designated building envelopes which ensure the protection of the riparian corridor areas. These riparian corridors will provide an important terrestrial and aquatic movement link to adjacent areas of bushland and riparian corridor.

Bushfire

Incorporating bushfire design principles into overall subdivision designs can substantially reduce the level of bushfire protection measures needing to be undertaken. Use of perimeter roads and the location of features such as private open space along the perimeter of bushfire prone lands can substantially reduce the encroachment of APZs into private allotments and hence the restriction of building envelopes or requirements for higher building construction standards. Given the prevailing low slope over most of the site, the APZs required for much of the site will be in the order of 25 – 35m.”

The *Ecology and Bushfire Constraints Report* provides the following general conclusions and recommendations:

“Overall, the planning proposal for rezoning this land to proposed zone R5 (Large Lot Residential) as presented in Figure 6, has responded well to the ecological, riparian and bushfire constraints present on the site. Retention of the core SSTF vegetation area, use of adequate riparian setbacks and development

restrictions, and the incorporation of perimeter roads around the nodes of development (and other bushfire protection measures) should enable future subdivision activity to occur which respects the current environmental values in the area. Consideration should be given to ensuring the best ecological outcomes for the site through the potential to either enter into biobank arrangements or potentially bio-certifying the LEP amendment. Additionally, approving designated building envelopes at subsequent subdivision stages will ensure the greatest retention of existing vegetation. Incorporating good bushfire design measures into future subdivision layouts will minimise or potentially eliminate the need for vegetation loss or modification to improve bushfire safety levels."

Also submitted with this Planning Proposal is a "Conceptual Development Area Plan" prepared by Taylor Brammer Landscape Architects that interprets detailed constraints mapping prepared by the project team. This Plan identifies the way in which sensitive parts of the subject site would be protected in future subdivision design. Of particular note is the setting aside of a large area at the centre of the site which is the most highly constrained in terms of bushfire and ecology. Whilst not considered necessary, it may be appropriate that site specific DCP provisions are developed to further address ecological aspects of the site. Irrespective, any future development application would be required to provide update studies of potential impacts on the ecology of the site.

9. Are there any other likely environmental effects as a result of the planning proposal and how are they proposed to be managed?

The impact of the Planning Proposal in terms of heritage, fauna and flora, bushfire, traffic and neighbourhood amenity have been discussed within this Planning Proposal and within the attached consultant reports. The conclusions of the *Ecology and Bushfire Constraints Report* are addressed above in Section C and the conclusions of the *Water and Sewer Servicing Report* and *Traffic Impact Review* are dealt with below in Section D. In addition, the *Aboriginal Heritage Due Diligence Assessment and Preliminary Non-Indigenous Heritage Assessment* prepared, concludes the following for Non-Indigenous heritage and Aboriginal heritage:

" **Non-Indigenous**

And the findings of the study:

- There are no non-Indigenous heritage listed sites within the study area;
- Two heritage listed sites within the vicinity of the study area will not be impacted by the proposed rezoning;
- There is a low potential for non-Indigenous archaeological remains to be present within the study area.

It is therefore recommended that:

- There are no know non-Indigenous heritage constraints within the study area;
- Further non-Indigenous heritage assessment or Statements of Heritage Impacts are not recommended;
- If unanticipated non-Indigenous heritage items or archaeological remains are identified within the study area, further assessment will be required to determine heritage significance.

Aboriginal

And the findings of the study:

- There are no recorded Aboriginal sites within the study area;
- The central portion of the study area has been assessed as having a moderate archaeological potential.

It is therefore recommended that:

- A further Aboriginal heritage assessment shall be prepared at development application stage for subdivision of the site covering the sections of the study area that have been assessed as having a moderate archaeological potential;

- There are no known Aboriginal heritage constraints on sections of the study area assessed as having a low archaeological potential and therefore no further Aboriginal archaeological work will be required in these areas;
- If unanticipated Aboriginal objects are located within the areas of low potential during future works further archaeological investigation and consents may be required;
- A copy of the Due Diligence Assessment should be forwarded to TLALC and CBNTCC for their comments."

There are no other aspects of the natural or built environment that require assessment as a result of the Planning Proposal.

It should also be noted that all consultant reports have been based on the "maximum yield scenario" from the "Conceptual Development Areas Plan" prepared by Taylor Brammer. Further refinement of lot yield and detailed design would obviously further consider environmental constraints in more detail at development application stage.

10. How has the planning proposal adequately addressed any social and economic effects?

The social and economic effects of the planning proposal have been considered in detail in the context of net public benefit analysis in Section 3. Community consultation and public authority consultation, will explore the Planning Proposal in more detail, as required.

SECTION D – State and Commonwealth Interests

11. Is there adequate public infrastructure for the planning proposal?

The site is contiguous to an established residential area, including residential subdivisions on St Heliers Road and Foxwood Close. The area near to the subject site is currently provided with electricity, telephone, water and sewerage services. The existing services and likely requirements for amplification are detailed in the *Water and Sewer Servicing Report* by Martens Consulting Engineers (refer to Annexure C). This report concludes that:

“ Water

Based on our preliminary network modelling, recommended water supply options for the site include:

Option 1 – Amplify Existing Services

If the entire site is to be serviced, then existing services will need to be amplified. This may include one or more of the following: (a) upgrade / additional supply network reticulation; (b) reservoir capacity augmentation; and (c) provision of water pressure booster system.

Option 2 – Build New Services

The site could be supplied with a new reservoir (around 665 KL would be required) and new supply reticulation. This is unlikely to be necessary given the outcomes of the preliminary network modelling.

Option 3 – Rainwater Harvesting

Individual dwellings could be serviced by a roof rainwater capture and storage system. Storage tanks in the order of 80-100 KL would be required at each dwelling site.

Option 4 – Part Site Serviced

Only part of the site is serviced (e.g. below say 180 mAHD) with the balance serviced by rainwater harvesting systems.

Sewer

The following comments / recommendations are made with respect to connection of the study area to the existing sewerage network servicing Silverdale:

- The nearest existing sewerage connection point to the study area is the existing 150 mm sewer main in St Heliers Road to the north of the study area. This main connects to another 150 mm main in Taylors Road. Preliminary analyses indicate that the load on the sewer main in Taylors Road is approximately 252 EP (72 lots at 3.5 EP/lot). WSA Sewerage Code WSA02-2002-2.2 (Sydney Water 2009) indicates that a 150 mm sewer main may service a maximum load of 600 EP. This would indicate that the main in Taylors Road may be able to accept an additional maximum load of 348 EP from the site, subject to the size and existing load on the downstream sewer main (currently unknown). Given the above loading rate of 3.5 EP/lot, this equates to a maximum of 99 additional lots that may be serviced by the existing mains.
- From the above preliminary analyses, it is likely that lots from the proposed sub-division of Lot 300 to the north of the study area would utilise any existing spare capacity in the main on St Heliers Road rather than lots within the study area.
- Several options may be available for providing sewer services for lots in the study area. These are summarised in Table 9.
- Preliminary discussions with Sydney Water have indicated that no information, aside from that indicated above, regarding existing capacities of the sewer network (including mains, pumping stations and sewage treatment works) in the vicinity of the study area would be available until such time as the proposed rezoning is lodged with Council."

Therefore services may require upgrading on the site however it is considered that there are no impediments to development in accordance with the planning proposal being adequately serviced.

In terms of public transport, a public bus route travels along Silverdale Road linking with Penrith, Wallacia, Mulgoa and Warragamba offering 9 services Monday to Friday. Traffic Impact Assessment has been undertaken by McLaren Traffic Engineering (refer to Annexure D). This report concludes that:

- " The proposed residential development of a maximum of 193 dwellings can be accommodated on the subject site within acceptable transport planning and traffic engineering criteria with particular regard to traffic flow efficiency and road safety."

In terms of commercial facilities in the locality, Silverdale is served by local shops that include a petrol station, video store, chemist, post office, supermarket, liquor store, medical centre, bakery, real estate, hairdresser, fitness studio and various professional services.

12. What are the views of State and Commonwealth public authorities consulted in accordance with the gateway determination?

State and Commonwealth authorities will be consulted in accordance with Section 57 of the EP&A Act, 1979, following the outcomes of the gateway determination.

3.7 Part 4 - Community Consultation

In accordance with Section 57(2) of the EP&A Act, 1979, the Director-General of Planning must approve the form of the planning proposal, as revised to comply with the gateway determination, before community consultation is undertaken.

Public exhibition is likely to include a newspaper advertisement, inclusion on the Council's web-site, written notification to adjoining landowners and a public meeting. The gateway determination will specify the level of public consultation that must be undertaken in relation to the planning proposal.

Pursuant to Section 57(8) of the EP&A Act, 1979 the Responsible Planning Authority must consider any submissions made concerning the proposed instrument and the report of any public hearing.

4 CONCLUSION

Redevelopment of the site for rural residential purposes is entirely consistent with Council's Growth Management Strategy 2011, which has been prepared in accordance with the NSW Metropolitan Strategy. It provides Wollondilly Council with a unique opportunity to contribute to the identified dwelling target for Silverdale/Warragamba of 1,000 dwellings for which just over half is met by current planning.

Extensive technical studies have been completed to accompany this Planning Proposal which focus on various environmental constraints and potential impacts. The subdivision density has been designed to respond to these constraints in a manner which will achieve an appropriate balance between management of natural site constraints and development of the land. Mapping of "Conceptual Development Areas" on the site indicate an example of how the site constraints may be interpreted in detailed design.

As required, technical reports can be appropriately revisited once the Planning Proposal proceeds through the *Gateway* process. The applicant acknowledges that further investigations into redevelopment of the land by various consultants may necessitate the preparation of some site specific DCP controls to assist in guiding future development.

The planning proposal has been prepared in accordance with Section 55 of the Environmental Planning & Assessment Act, 1979, as well as the NSW Department of Planning publications "*A Guide to Preparing Planning Proposals*" and "*A Guide to Preparing Local Environmental Plans*".



ANNEXURE A

ECOLOGY AND BUSHFIRE CONSTRAINTS REPORT

ECOLOGICAL AUSTRALIA PTY LTD



ECOLOGY AND BUSHFIRE CONSTRAINTS REPORT – SILVERDALE COMBINED PROPERTIES

Prepared for
ESTALL c / o Planning Ingenuity

6 February 2012



DOCUMENT TRACKING

ITEM	DETAIL
Project Name	Ecology and Bushfire Constraints Report – Silverdale Combined Properties
Project Number	11WOLECO-0020
File location	W:\Synergy\Projects\11WOLECO\11WOLECO-0020 Silverdale, Eltons Rd - Preliminary Ecological and Bushfire Constraints Analysis\Report\Draft Reports
Project Manager	Sally Perry 4201 2206 Suite 204, Level 2, 62 Moore Street Austinmer 
Prepared by	Sally Perry
Approved by	Steve House
Status	Final
Version Number	1
Last saved on	4 April 2012
Cover photo	Various Locations within subject site

This report should be cited as „Eco Logical Australia February 2012. Ecology and Bushfire Constraints Report – Silverdale Combined Properties. Prepared for ESTALL Pty Ltd c / o Planning Ingenuity“

ACKNOWLEDGEMENTS

This document has been prepared by Eco Logical Australia Pty Ltd with support from Planning Ingenuity, Taylor Brammer Architects and Lean and Hayward.

Disclaimer

This document may only be used for the purpose for which it was commissioned and in accordance with the contract between Eco Logical Australia Pty Ltd and ESTALL. The scope of services was defined in consultation with ESTALL, by time and budgetary constraints imposed by the client, and the availability of reports and other data on the subject area. Changes to available information, legislation and schedules are made on an ongoing basis and readers should obtain up to date information.

Eco Logical Australia Pty Ltd accepts no liability or responsibility whatsoever for or in respect of any use of or reliance upon this report and its supporting material by any third party. Information provided is not intended to be a substitute for site specific assessment or legal advice in relation to any matter. Unauthorised use of this report in any form is prohibited.

Contents

1	Property and Proposal Background	5
1.1	Background.....	5
1.2	The site	5
2	Ecological Values	7
2.1	Data review.....	7
2.2	Field Survey.....	7
2.3	vegetation communities.....	7
2.3.1	Shale Sandstone Transition Forest	11
2.3.2	Cumberland Plain Woodland.....	11
2.4	Flora.....	12
2.5	fauna.....	12
3	Riparian Values and Corridors.....	13
4	Bushfire Considerations.....	17
4.1	Bushfire threats	17
4.2	Slope.....	19
4.3	Vegetation.....	19
4.4	Bushfire Protection measures	19
5	Assessment of Planning Proposal	21
5.1	Ecology	21
5.2	Riparian	22
5.3	Bushfire.....	22
6	Conclusion	23
	References	25
	Appendix A: Likelihood of Occurrence Tables	26
	Appendix B: Flora and Fauna Species List	35

List of Figures

Figure 1: The Subject Site.....	6
Figure 2: Vegetation Communities on Site (based on NPWS 2002 Western Sydney Vegetation Mapping).....	9
Figure 3: Validated extent and condition of vegetation communities on site.....	10
Figure 4: Wollondilly LEP Natural Resources (Water) and identified sensitive lands.....	14
Figure 5: Bushfire Prone Lands Map (Extract from (DRAFT) Wollondilly Shire Council Bushfire Prone Land Map 2011).....	18
Figure 6: Conceptual Development Area.....	24

List of Tables

Table 1: Areas of validated vegetation community on site.....	12
Table 2: RCMS Riparian Corridor Categories, widths and key management objectives.....	15
Table 3: Potential RCMS watercourse categorisations.....	16
Table 4: Required Asset Protection Zones (according to PBP 2006).....	19

Abbreviations

ABBREVIATION	DESCRIPTION
CPW	Cumberland Plain Woodland – a Critically endangered ecological community
DECCW	Formerly NSW Department of Environment, Climate Change and Water, Now NSW Office of Environment and Heritage
EPA Act	NSW Environmental Planning and Assessment Act (1979)
EPBC Act	Commonwealth Environment Protection and Biodiversity Conservation Act (1999)
NOW	NSW Office of Water
PBP 2006	NSW Rural Fire Service “Planning for Bushfire Protection” Guidelines (2006)
RCMS	Riparian Corridor Management Study
SEWPAC	Commonwealth Department of Sustainability, Environment, Water, Population and Communities
SSTF	Shale Sandstone Transition Forest
WLEP 2011	Wollondilly Local Environment Plan (2011)

1 Property and Proposal Background

1.1 BACKGROUND

The owners of numerous properties within the Silverdale area have formed an Owner's group, ESTALL, in order to progress a potential rezoning and subsequent subdivision and redevelopment of their land parcels.

The subject site is approximately 166.8ha in size and consists of the following lots;

- Lot 11 in DP 578088
- Lot 2 in DP 562249
- Lots 1, 2 and 3 in DP 734838
- Lots 48 - 52 in DP 236542
- Lots 12 – 16 in DP 247872

The site is essentially bounded by Eltons Road to the south, Taylors Road to the East, St Heliers Rd and Barrington Rd to the north and Silverdale Road further to the west (see Figure 1). The subject site is within Wollondilly Local Government Area and subject to the controls of the Wollondilly Local Environment Plan 2011, Wollondilly Development Control Plan, 2011 and a range of other planning controls and policies.

Eco Logical Australia have been requested to assess the constraints and opportunities on site in relation to ecological and bushfire issues. This assessment has drawn on a range of existing information and general knowledge of the subject site, in addition to a field inspection undertaken on Monday 19 September 2011.

1.2 THE SITE

Currently the lots within the subject site are used for a variety of low intensity grazing, market gardens, wholesale nursery operations and hobby farms. A large area of remnant native bushland exists through the centre of the site which creates a bushfire hazard to these properties and to adjacent properties to the north and south of the subject site. The subject site is surrounded on the north and east sides by small lot, low density housing development, to the south side by large lot rural residential / low intensity agriculture and to the west by significant areas of remnant bushland within the Warragamba catchment lands. Several watercourses run through the subject site, essentially draining from south-west to north-east and there are numerous small to medium sized farm dams.

The south-western portion of the site contains land with significant slopes, while generally the land in the eastern and northern part has gentler slopes. Residential dwellings and other structures exist on some of the allotments within the site, while other lots do not currently contain built items.

Immediately adjacent to the northern boundary of this site, Lot 300 DP 12076326 is the subject of a separate planning proposal for subdivision into low density housing. Field work was carried out on all sites apart from Lot 2 DP 562249.

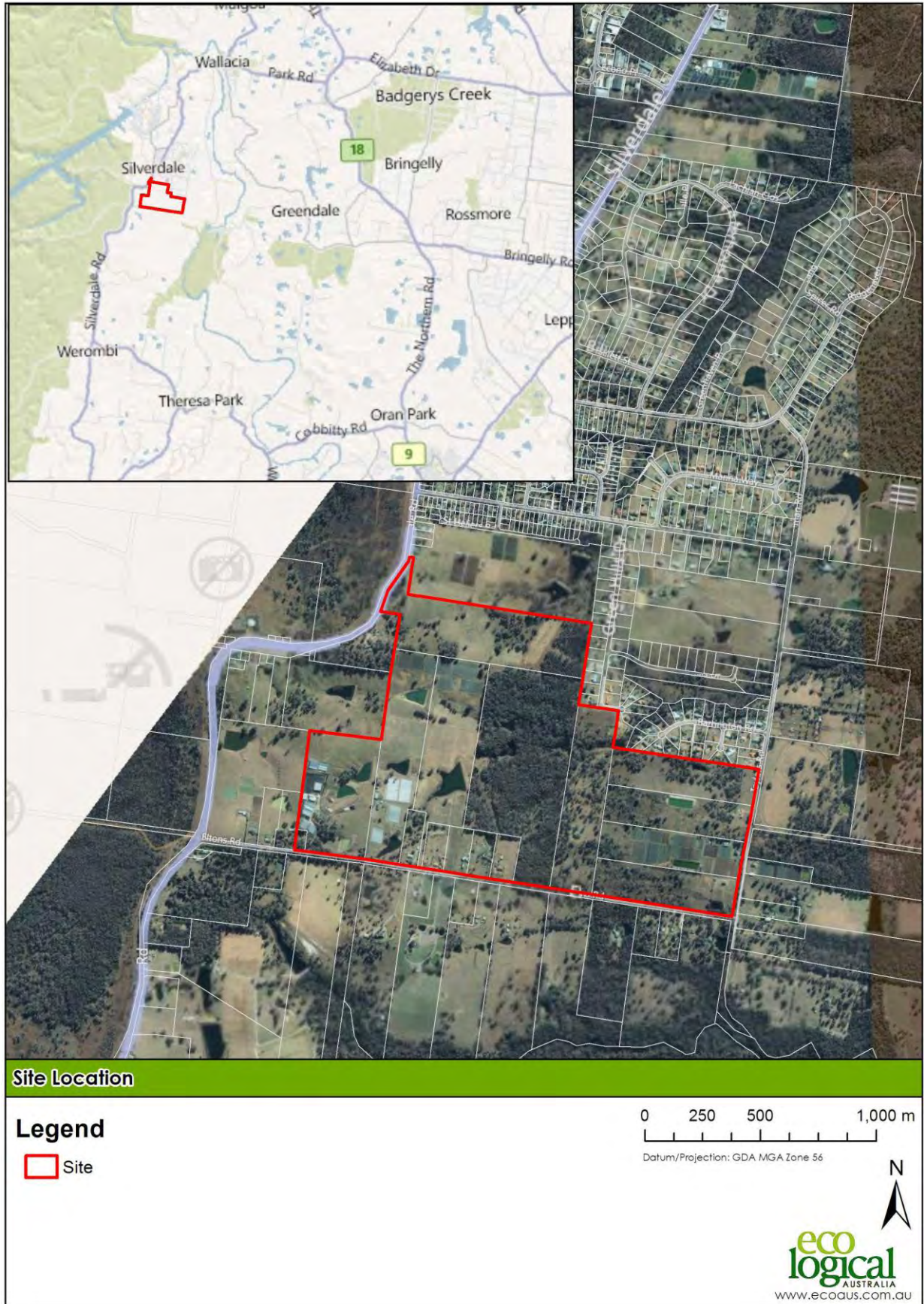

Figure 1: The Subject Site

2 Ecological Values

2.1 DATA REVIEW

The following information and databases were reviewed prior to the field survey:

- NSW NPWS (2002) Western Sydney vegetation mapping,
- Atlas of NSW Wildlife database (now Bionet),
- EPBC Protected Matters Search tool,
- Planning Submission from Planning Ingenuity on the Draft Growth Management Strategy (2010).

A list of potential threatened species and endangered ecological communities was generated from the results of the NSW Wildlife Atlas and EPBC Protected Matters Search. All species and communities that had the potential to occur on the subject site or in the vicinity were considered during the brief field survey.

2.2 FIELD SURVEY

The study area was surveyed by Field Ecologist Anna Foley and Senior Environmental Consultant, Sally Perry on Monday 19th September for a total of 12 person hours. The weather conditions on the day were a minimum temperature of 14°C and maximum temperature of 28°C. No rainfall had fallen within the previous 24 hours, and relative humidity on the day was at 64% with moderate strength North-North-East winds (recordings taken from Bureau of Meteorology website).

Random traverses of the lots within the subject area were undertaken to collect specific data in regards to the presence and condition of endangered ecological communities on site, the habitat values and potential for threatened flora and fauna species and any other significant site features. All visible flora and fauna observed on site were recorded and are listed in Appendix B. The extent and condition of vegetation communities present on site was also verified. *NB: No field work was undertaken on the northern lot (Lot 2 DP 562249) due to it not forming part of this study area at the time of survey.*

2.3 VEGETATION COMMUNITIES

The NSW NPWS (2002) Western Sydney vegetation mapping for this area showed a mixture of vegetation communities present on the site, in a variety of ecological conditions. These included:

- Cumberland Plain Woodland (both Shale Hills and Shale Plains sub communities)
- Shale Sandstone Transition Forest (both the low and high sandstone influence sub-communities)
- Moist Shale Woodland, and
- Several areas of unclassified vegetation.

Of these vegetation communities Shale Sandstone Transition Forest and Moist Shale Woodland are listed as Endangered Ecological Communities (EECs) under the NSW *Threatened Species Conservation Act* (1995) (TSC Act), while Cumberland Plain Woodland is listed as a *critically*

endangered ecological community (CEEC) under the TSC Act. Further, CPW and SSTF are also listed under the Commonwealth *Environment Protection and Biodiversity Conservation Act* (1999) as a CEEC and EEC respectively. The original desktop based mapping of these communities is shown in Figure 2.

The main vegetation community present on site is Shale Sandstone Transition Forest (SSTF), with both the the high and low sandstone influence sub communities present. The level of sandstone bedrock underlying underlying the vegetation influences the relative dominance of certain canopy species in the vegetation community. The area of SSTF present onsite was mapped originally by NSW NPWS at approximately 72.43ha. There were small areas of remnant CPW in the very south-west of the site, on the steeper slopes around the numerous dams totalling 1.29 ha. The NSW NPWS (2002) mapping showed small areas areas mapped as Moist Shale Woodland, however based on the field investigations this area has been re-classified as CPW subsequent to the field inspection. The validated extent and condition of the various various vegetation communities onsite is mapped in

Figure 3.

Much of the remnant vegetation on site remains in good condition and has a moderate to good recovery potential. There is good canopy cover of most of the patches remaining onsite. Current land management practices such as grazing, slashing and mowing are severely impacting the mid-storey and ground cover layers at present, however if these influences were removed or modified, the level of natural regeneration likely to occur is considered to be quite high.

In regards to the mapping presented below, the condition classes assigned follow the NSW NPWS (2002) Western Sydney vegetation mapping procedure. This can be summarised as follows:

Condition A – Canopy Cover is greater than 10%, relatively intact native tree canopy.

Condition B – Canopy Cover 5 – 10%, somewhat discontinuous canopy with native shrub and grass layer.

Condition C – Areas of native vegetation which do not have a Eucalypt canopy cover but understorey is dominated by native species.

Condition Tx – Areas of native trees with very discontinuous canopy cover of <10% and with agricultural surrounding land uses.

Essentially, all vegetation coded as A, B and C can be considered in Good Condition and all vegetation coded as TX can be considered Poor Condition.

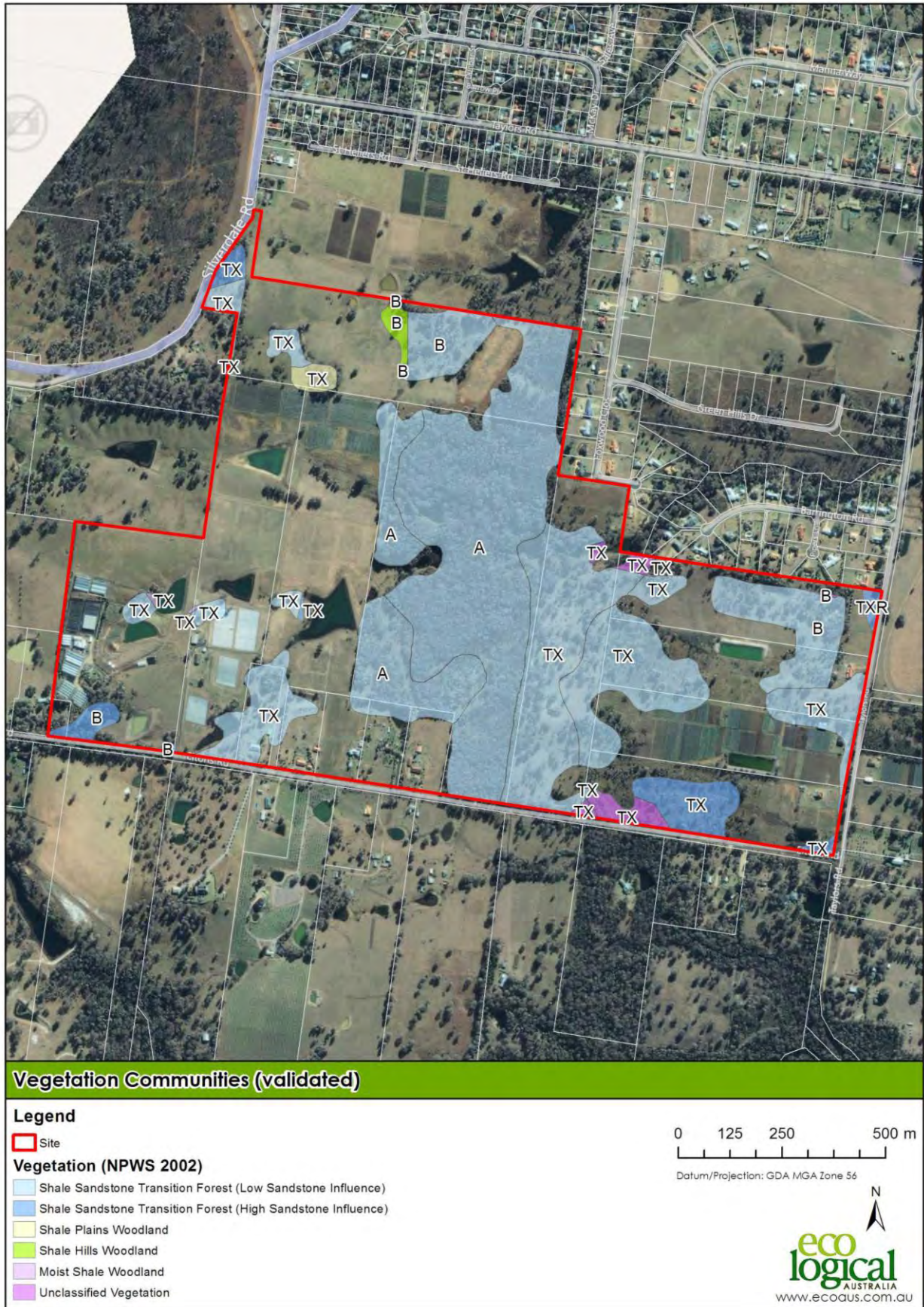

Figure 2: Vegetation Communities on Site (based on NPWS 2002 Western Sydney Vegetation Mapping)

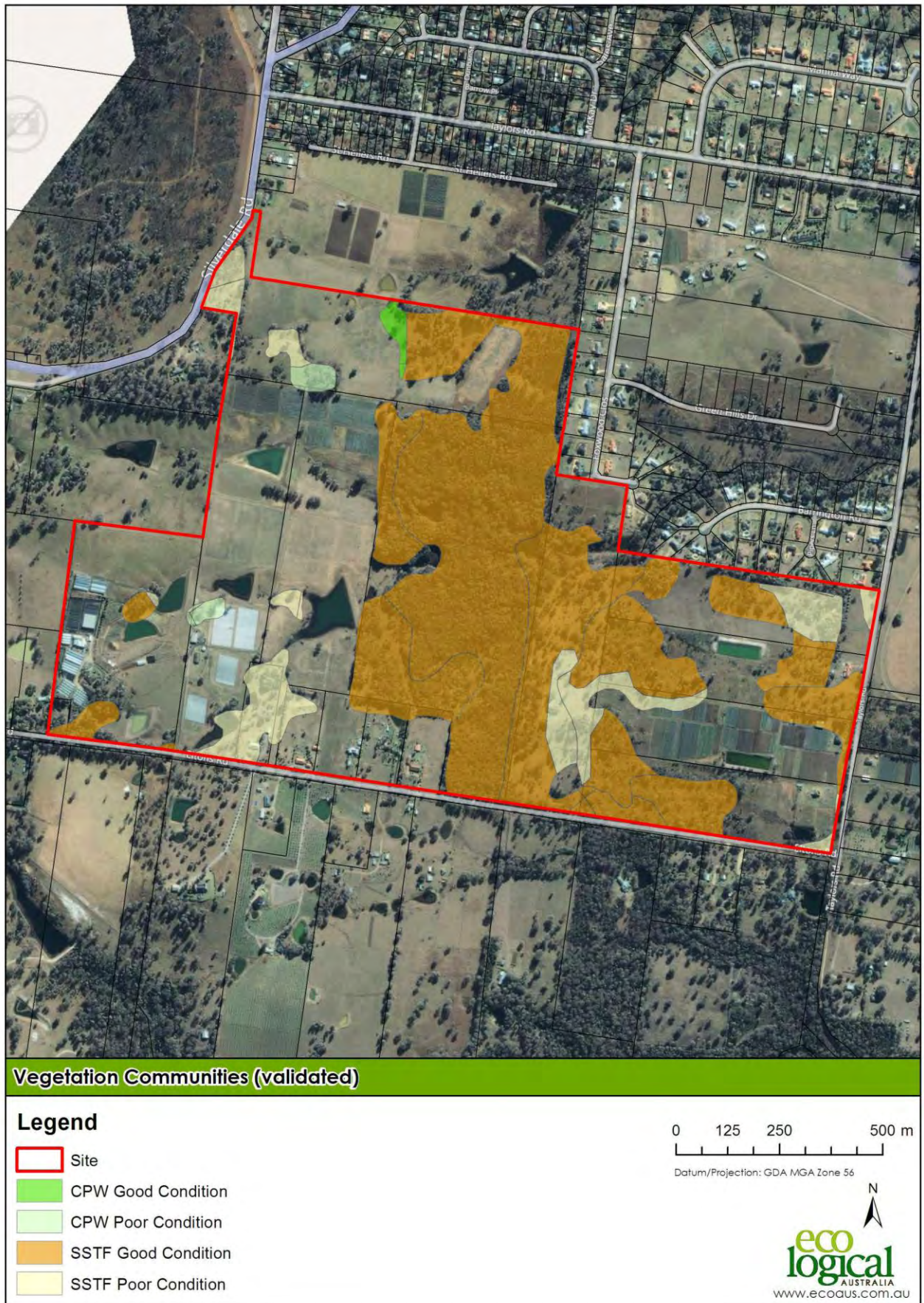

Figure 3: Validated extent and condition of vegetation communities on site.

2.3.1 Shale Sandstone Transition Forest

Shale Sandstone Transition Forest (SSTF) was identified across much of the site, mostly as large patches of modified vegetation that are partially fragmented within the local landscape. SSTF occurs at the edges of the Cumberland Plain, where clay soils from the shale rock inter-grade with soils from sandstone bedrock.

The areas of SSTF on site have an open woodland to forest structure that has been modified by grazing, cropping, slashing and other disturbance (such as a high intensity bushfire approximately 10 years prior). The areas mapped as SSTF have a canopy of *Eucalyptus tereticornis* (Forest Red Gum), *E. eugenioides* (Thin-leaved Stringybark), *Syncarpia glomulifera* (Turpentine), *E. crebra* (Narrow-leaved Ironbark), *E. fibrosa* (Broad-leaved Ironbark), *E. punctata* (Grey Gum), *Corymbia eximia* (Yellow Bloodwood) and *Corymbia maculata* (Spotted Gum).

The areas of *Low Sandstone Influence* are dominated by *E. tereticornis* and *E. eugenioides*, while areas of *High Sandstone Influence* are dominated by *E. punctata*, *E. crebra* and *E. fibrosa*. Although the eucalypts present were regenerating, where grazing pressure is currently sustained, this is restricting the recruitment of juvenile canopy species.

Mid-storey species were sparsely distributed, including *Allocasuarina littoralis* (Black She-oak) and *Acacia parramattensis* subsp. *parramattensis* (Sydney Green Wattle) with *Bursaria spinosa* (Sweet Bursaria) and *Acacia brownii* (Heath Wattle).

The grassy understorey was dominated by *Aristida ramosa* (Purple Wiregrass), *Aristida vagans* (Three-awn Speargrass), *Microlaena stipoides* var. *stipoides* (Weeping Grass) and *Themeda australis* (Kangaroo Grass). Other graminoids occur, such as *Lomandra filiformis* subsp. *filiformis* (Wattle Mat-rush) and *Lomandra multiflora* subsp. *multiflora* (Many-flowered Mat-rush), with sparsely distributed native herbs such as *Glycine clandestina* and *Dichondra repens* (Kidney Weed). The tall native rush, *Eleocharis sphacelata*, dominates the farm dam in the centre of the property at 153 Eltons Road.

2.3.2 Cumberland Plain Woodland

Very small areas of another Cumberland Plain Woodland (i.e. either Shale Hills Woodland or Shale Plains Woodland) have been mapped within the study area. Cumberland Plain Woodland is associated with clay soils derived from the Wianamatta Group geology on the Cumberland Plain of Western Sydney. The community typically occurs on flat to undulating or hilly terrain and typically occurs as a grassy open canopy, woodland vegetation formation with a near continuous groundcover.

These very small patches are highly modified, and retain little ecological integrity within the understorey however the canopy level does contain several significant trees and several have potential habitat hollows. Based on the presence of *E. eugenioides* and *E. tereticornis* within these areas, it is considered that this vegetation lies on an *ecotone* (i.e. a transition zone) between the CPW and SSTF two communities. A detailed floristic assessment of the site would be required to map the exact boundary of the two communities. The small area of vegetation classified in the NPWS 2002 desktop vegetation mapping project as Moist Shale Woodland has been reclassified as CPW.

Figure 3 below shows the validated areas and conditions of the vegetation communities on site while Table 1 shows the validation of the extent and condition of different vegetation communities.

Table 1: Areas of validated mapped and vegetation community on site

Vegetation Community	NPWS (2002)	NPWS (2002)	#Validated	#Validated
	Good Condition*	Poor Condition**	Good Condition	Poor Condition
Shale Sandstone Transition Forest	42.49 ha	29.94 ha	64.12 ha	11.36 ha
Cumberland Plain Woodland	0.60 ha	0.69 ha	0.60 ha	1.07 ha
Moist Shale Woodland	0.0 ha	0.09 ha		
Unclassified	0.02 ha	1.49 ha	0.0 ha	0.0 ha
Total Area veg on site	43.11 ha	32.21 ha	64.72 ha	12.43 ha

*Based on NSW NPWS (2002) desktop mapping vegetation condition classes, where Good Condition = all Condition A, B and C vegetation, .where A = > 0.5ha patch size, relatively intact native tree canopy, dominant canopy and understorey species are identified: B = .5 ha patch size, canopy cover of 5 = 10 % with unknown midstorey and groundcover composition: C = 0.5ha patch size canopy dominated by native species excluding Eucalypts:

**Based on NSW NPWS (2002) desktop mapping vegetation classes where Poor Condition = all Condition Tx, Txr and Txu vegetation, where Tx/ Txr / Txu = are all areas of native trees with discontinuous canopy cover and located in agricultural, rural residential or urban settings respectively.

#Validated data is based on results of field inspection revising vegetation community boundaries.

2.4 FLORA

The NSW Wildlife Atlas search (now Bionet) lists as total of 6 threatened plant species as occurring within a 10km radius of the site. Additionally, the Commonwealth database lists a total of 14 threatened plant species as occurring within a 10km radius of the site. No threatened flora species were identified on site during the survey, however the survey effort was not exhaustive. A list of all flora species observed on site is included in Appendix B.

2.5 FAUNA

The NSW Wildlife Atlas search lists a total of 22 threatened fauna as being recorded within 10km of the site, while the Commonwealth database lists a total of 19 threatened fauna species and 12 migratory birds within a 10km radius.

No listed threatened fauna species were encountered on site during the limited field survey. Numerous trees on site contain hollows which could be utilised by a range of fauna species, including several of the listed bat species. Also, the site's close proximity to large areas of good quality habitat in the Warragamba Catchment Lands and the Gulguer Nature Reserve / Bents Basin State Conservation Area increase the likelihood that the some of these threatened species would utilise the site from time to time. A list of the fauna species observed on site is included in Appendix B.

3 Riparian Values and Corridors

There are several watercourses within the subject site: the location of the numbered stream reaches is shown in Figure 4. The majority of the stream reaches on site have had the majority of streambank vegetation removed or highly modified over time, with little natural riparian vegetation remaining. The banks of the watercourses are in reasonable condition in most parts, however there are some significant localised erosion points particularly in the steeper sections in the south-west portion. Overall the riparian corridors have a moderate to good natural recovery potential.

The onsite dams provide a varying degree of aquatic habitat, depending on the amount, type and variety of aquatic and fringing vegetation. The dams within the south-west corner of the site contained little aquatic or fringing vegetation and the water quality appeared to be impacted by runoff / seepage from nursery operations. If the large remnant, hollow bearing trees on the surrounding banks are utilised by bats, birds and other arboreal mammals, these dams may be providing a secure water source for these animals.

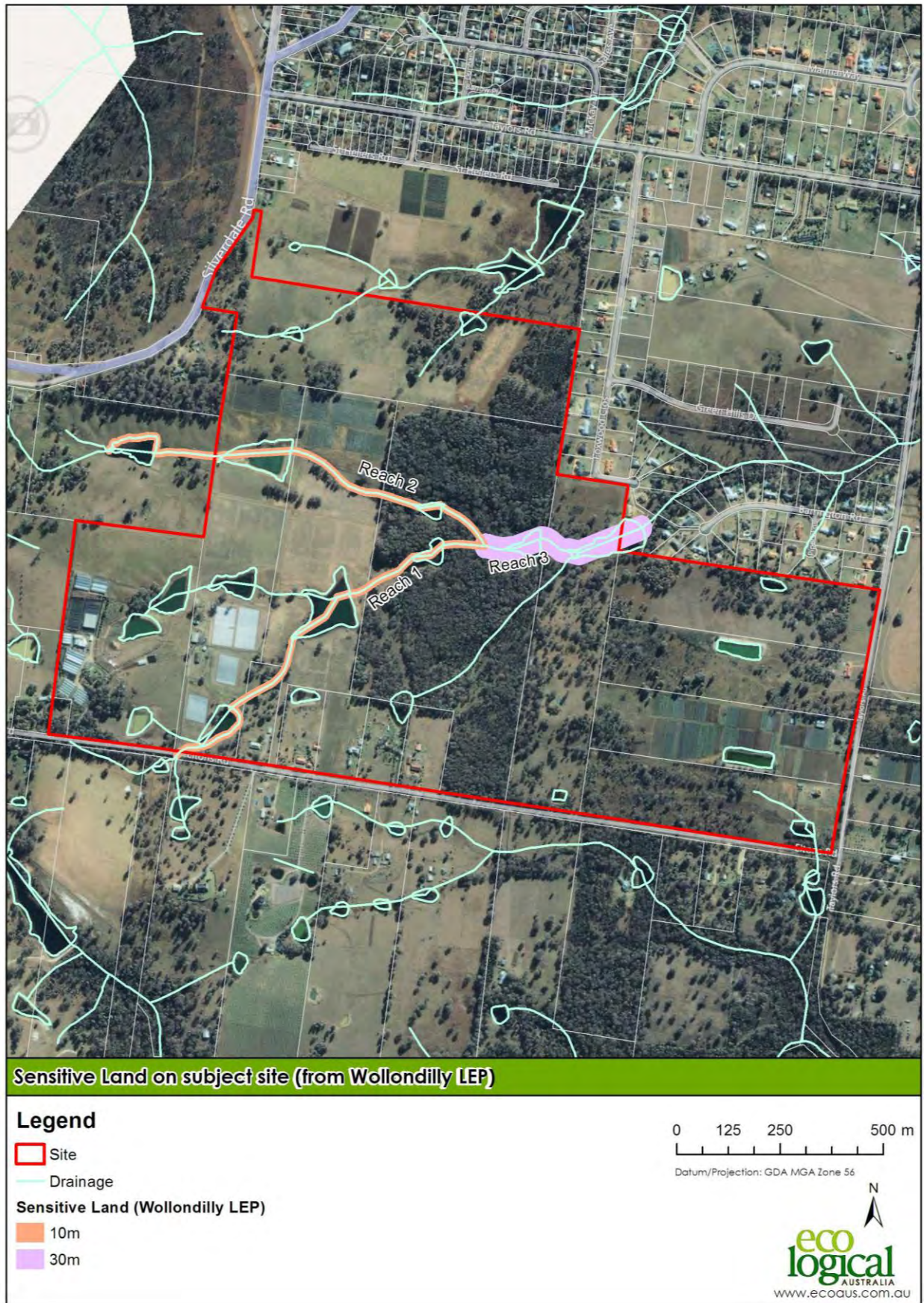

Figure 4: Wollondilly LEP Natural Resources (Water) identified sensitive lands and watercourses on site

The Wollondilly LEP 2011 identifies lands adjacent to watercourse channels as “sensitive lands”. The width of sensitive lands on each stream bank is based on the hydraulic significance of the watercourse and determined by its Strahler Stream order. Sensitive Land is measured from the Top Of Bank on each side of the watercourse. These sensitive lands are designed to maintain the hydrological functions of riparian lands, waterways and aquifers, including protection of the following:

- Water quality,
- Natural water flows,
- The stability of bed and bank of waterways, and
- Groundwater systems.

The LEP has identified that two different widths of sensitive land occur on the subject site. Reaches 1 and 2 have 10m of sensitive land on each side of the watercourse, and Reach 3 has 30m on each side.

These areas of sensitive land are intended to form a riparian corridor which not only safeguards the hydraulic integrity of the watercourse and the water quality within the creek, but also provides an intact aquatic and terrestrial movement link to adjacent natural areas.

It is likely that these watercourses will be re-assessed by Wollondilly Shire Council and / or the NSW Office of Water at the time of rezoning and the watercourses will be subject to assessment under the Riparian Corridors Management Study (RCMS) methodology. The RCMS assessment allows for the integration of strategic management objectives into the designation of stream categories. Objectives have been outlined for each of the stream category classes, as well as appropriate riparian corridor widths comprised of a Core Riparian Zone (CRZ) and adjacent Vegetated Buffer (VB), as measured from the Top of Bank and are reproduced in Table 2.

Table 2: RCMS Riparian Corridor Categories, widths and key management objectives

Stream Category	Minimum Riparian Corridor Widths	Key Objectives
1 – Key Environmental Corridor	40m CRZ + 10m VB	<ul style="list-style-type: none"> • Protect, restore and maintain continuous, vegetated riparian corridors for the movement of flora and fauna species through and beyond its catchment, • Provide extensive habitat and connectivity between habitat nodes for both terrestrial and aquatic fauna, • Maintain the viability of native riparian vegetation, • Provide a continuous, viable Core Riparian Zone (CRZ) which emulates the native vegetation communities in the areas to facilitate a stable watercourse, • Provide a 10m Vegetated Buffer (VB) on either side of the CRZ, to protect the environmental integrity of the CRZ from weed invasion, microclimate changes, litter, trampling and pollution by emulating the native vegetation communities in the area.
2 – Terrestrial and Aquatic Habitat	20m CRZ + 10m VB	<ul style="list-style-type: none"> • Maintain and restore the natural functions of a stream and its aquatic and terrestrial qualities, • Maintain the viability of native riparian vegetation, • Provide suitable habitat for local terrestrial and aquatic fauna, • Provide a continuous, viable Core Riparian Zone (CRZ) which

		<p>emulates the native vegetation communities in the area to facilitate a stable watercourse,</p> <ul style="list-style-type: none"> • Provide a 10m Vegetated Buffer (VB) either side of the CRZ, to protect the environmental integrity of the CRZ from weed invasion, microclimate changes, litter, trampling and pollution by emulating the native vegetation communities in the area.
3 – Bed and Bank Stability	10m CRZ	<ul style="list-style-type: none"> • Retain, maintain and restore where possible the natural functions of a stream including bed and bank stability to protect local water quality, • Provide a continuous, viable CRZ which emulates the native vegetation communities in the area to facilitate a stable watercourse.

In regards to the RCMS categorisation of streams and the required protection and management of riparian corridors, it is likely that the rezoning investigations by WSC and or NSW Office of Water will allocate the following water course categories to the watercourse reaches on site.

Table 3: Potential RCMS watercourse categorisations

Reach Number	WLEP 2011 Sensitive Land Width	Likely RCMS Category	Stream	Required Corridor	Riparian
Reach 1	10m	3		10m CRZ	
Reach 2	10m	3		10m CRZ	
Reach 3	30m	2		20m CRZ + 10m VB	

Development activity within these future riparian corridors will be restricted, would need to consistent with the objectives of the category and ensure no deterioration in the:

- Water quality of receiving waters,
- Natural flow regime,
- Natural flow paths of waterways,
- Stability of the bed, shore and banks of waterways, and
- Flows, capacity and quality of groundwater systems (WLEP 2011, Section 7.3).

4 Bushfire Considerations

4.1 BUSHFIRE THREATS

Bushfire threats to the site include:

- The existing bushland on site, and any requirements for retention,
- Adjacent bushland on neighbouring lands,
- Potential requirements for retention and / or restoration of riparian corridors.

The subject site contains several areas of Bushfire Prone Land according to Wollondilly Shire Council's Bushfire Prone Lands map. There is a large area of remnant native vegetation within the site, as well as several patches of vegetation existing on adjacent lands which present a bushfire hazard to the subject. The Bushfire Prone Lands within the subject site are shown in Figure 5. A combination of vegetation categories 1 and 2 are present on site. The large area of SSTF vegetation on site (located mainly within Lot 52 DP 236542 and Lot 16 DP 247872) is unlikely to be approved for removal or substantial modification, hence the bushfire threat posed to the surrounding lands by this patch will remain.

The bushfire prone vegetation offsite to the west is generally at a high elevation than the subject site (ie it exists at an upslope) and therefore present a lower danger to the site as bushfires burn slower and at a lower intensity in a downhill direction.

The bushfire prone vegetation offsite to the east (east of Foxwood Close / Taylors Road) exists at lower elevation than the subject site (i.e. it exists at a downslope) and does provide a slight uphill fire run to the subject site. This vegetation is associated with the watercourse which runs west to east through the subject site and continues eastward offsite and at its widest point is approximately 120m wide.

The bushfire prone vegetation to the south of the subject land essentially exists at a level to slightly lower elevation (i.e. at a downslope) to the subject land and is continuous with a very large area of vegetation which extends to the south, east and west and continues onto the Bents Basin State Conservation Area on the Nepean River.

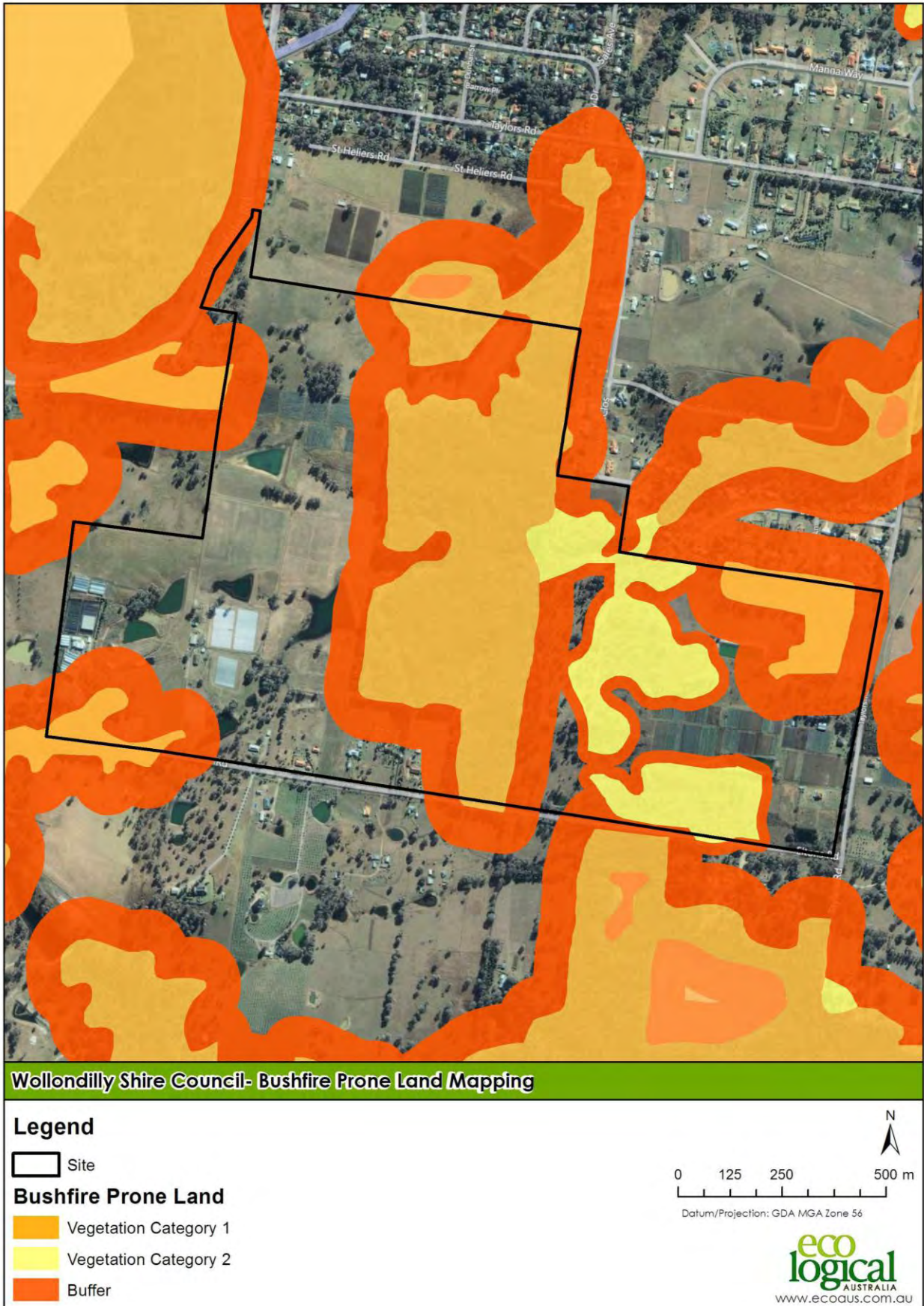

Figure 5: Bushfire Prone Lands Map (Extract from (DRAFT) Wollondilly Shire Council Bushfire Prone Land Map 2011)

4.2 SLOPE

The slope across most of the site is gentle. The average slope across the vast majority of land is approximately 5°. Slopes in the immediate vicinity of the watercourses tend to increase slightly, with averages of about 8°.

There are very steep sections of the site in the south-west corner where slopes exceed 20°. The bushfire prone vegetation in this steep portion of the site area exists at a level or higher elevation to the surrounding land, and presents a lower danger to the surrounding (developable) lands on the site.

4.3 VEGETATION

The vegetation on site is predominantly Shale Sandstone Transition Forest (SSTF), with small relatively isolated patches of Cumberland Plain Woodland and pasture grass. According to NSW RFS Planning for Bushfire Protection, where a variety of vegetation types is present on site, the vegetation type presenting the greater hazard level is used for determining the relevant vegetation formation. In regards to the vegetation formation classes under Keith (2004), SSTF is considered to be a “Forest” Formation (Dry Sclerophyll Shrubby Formation) for the purposes of determining bushfire Asset Protection Zones.

The NSW Rural Fire Service have recently advised that grasslands are to be added to the description of bushfire prone vegetation. This change would essentially render the entire remainder of the site as Bushfire Prone Land, given that the non-forested remainder of the site is a combination of managed and unmanaged grasslands. All construction works within bushfire prone land must comply with Australian Standard AS3959:2009 “Construction of buildings in bushfire prone areas”. Accordingly, the designation of grasslands as Bushfire Prone Land would require all future residential construction to comply with AS 3959.

4.4 BUSHFIRE PROTECTION MEASURES

Table 4 shows the required bushfire Asset Protection Zones for residential development subdivision occurring adjacent to Forest vegetation formations. (*NB: Downslope grades are when the hazard exists below the asset, and Upslope grades are when the hazard exists above the asset*).

Table 4: Required Residential Asset Protection Zones (according to PBP 2006)

Slope	APZ
Upslope	20m
Downslope 0 - 5°	25m
Downslope 5 - 10 °	35m
Downslope 10 - 15°	50m
Downslope 15 - 18°	60m

Other bushfire protection measures will be required for any subsequent residential subdivision and development on site. These include the use of perimeter roads and specified access arrangements, relevant construction standards for dwellings and other development types, requirements for water hydrant location and spacing, requirements for gas and electricity supply. These will need to be

determined at the subdivision stage. If other types of development are proposed on any of the future allotments (such as Special Fire Protection Purposes), much larger APZs will be required and additional bushfire protection measures would be required to safeguard occupants of these developments (such as Emergency Evacuation Plans, Emergency Management Committees, etc).

5 Assessment of Planning Proposal

The ESTALL land owners group are seeking a rezoning of their land parcels from its current zoning of RU2 – Rural Landscape to R5 – Large Lot residential, with a minimum allotment size of 4000sqm. Preliminary site and planning investigations have resulted in the production of Conceptual Development Areas, as shown in Figure 6.

The subject site contains several constraints to its future development, given the large area of good quality SSTF vegetation, the location of this vegetation in the centre of the site creating a bushfire risk to surrounding lands, the areas of steep land with slopes greater than 20° and the location and route of several watercourses.

5.1 ECOLOGY

A large, relatively intact stand of SSTF vegetation runs through the centre of the subject site. Several smaller stands of SSTF and CPW vegetation are also spread across the site. The majority of vegetation remaining on site is in a good condition with a moderate to high recovery potential. Both vegetation communities are designated as Endangered or Critically Endangered Ecological Communities under both the NSW TSC Act and Commonwealth EPBC Act. Any proposal that would negatively impact on this vegetation will require an assessment of the significance of that impact under both the TSC and EPBC Acts.

The current Conceptual Development Areas Plan (Figure 6) shows the central stand of SSTF vegetation on site (approximately 33 ha) as not proposed for future subdivision / development. This vegetation should be retained and enhanced, which will also increase its value as a link between adjacent larger areas of good quality vegetation and improve regional connectivity. Maintaining this large stand of vegetation in one ownership should ensure better conservation outcomes and enable positive biodiversity outcomes to be explored such as securing this area as an offset site for development impacts resulting from eventual subdivision and residential development activity on the remainder of the site. This area also has potential to become a registered biobank site which would provide for in-perpetuity protection and management of the vegetation on site.

The smaller, isolated areas of SSTF and CPW on site could largely be retained through the appropriate subdivision design and approval of suitable building envelopes with future subdivision applications. The use of minimum 4000 ha allotments should ensure that where small stands of this vegetation occurs, adequate building envelopes (including bushfire APZs) can be provided which do not conflict with the goal of maintaining and enhancing the condition and extent of these endangered ecological communities. Innovative urban design solutions such as cluster housing could also improve ecological outcomes by focussing urban development in the most suitable parts of the site – i.e. areas with lowest ecological value, which will generally also correspond to areas with lowest bushfire threat and exposure.

5.2 RIPARIAN

The watercourses are in reasonable ecological condition at present and provide some level of aquatic habitat. Little remnant riparian vegetation exists for the most part.

Wollondilly LEP 2010 has designated areas of land adjacent to these watercourses as „sensitive land“, the development or use of which is limited. Similarly, the NSW Office of Water identifies required riparian corridors depending on the RCMS watercourse categorisations, which are to be retained and managed for environmental and water flow objectives.

The use of 4000sqm minimum lot sizes should enable sufficient land to be available for the erection of a dwelling outside these sensitive lands as well as the maintenance and protection of a functioning, intact riparian corridor. This can be further ensured at subdivision stage through the approval of designated building envelopes which ensure the protection of the riparian corridor areas. These riparian corridors will provide an important terrestrial and aquatic movement link to adjacent areas of bushland and riparian corridor.

A different option for consideration would be the creation of one single allotment containing all the designated riparian lands and maintaining this allotment in one ownership and dedicating it to a public authority (such as Wollondilly Shire Council or NPWS) for ownership and ongoing management. This would ensure a consistent management regime along the riparian corridor. This may require the private lots adjacent to the riparian corridors to be created at a smaller size than 4000sqm.

5.3 BUSHFIRE

Bushfire threats to the site exist from vegetation both on the subject site as well as vegetation offsite. The proposed retention of the large area of SSTF through the centre of the site will mean that developable land surrounding this vegetation will need to consider adequate bushfire protection measures in the detailed subdivision design. Similarly, retention of the open watercourses and eventual restoration of these riparian corridors will present a future bushfire risk to land adjacent to the corridors.

Incorporating bushfire design principles into overall subdivision designs can substantially reduce the level of bushfire protection measures needing to be undertaken. Use of perimeter roads and the location of features such as private open space along the perimeter of bushfire prone lands can substantially reduce the encroachment of APZs into private allotments and hence the restriction of building envelopes or requirements for higher building construction standards. Figure 6 shows the use of perimeter roads around the vast majority of areas proposed for development. Given the prevailing low slope over most of the site, the APZs required for much of the site will be in the order of 25 – 35m.

Detailed subdivision design will need to ensure that designated APZ areas and perimeter roads are located outside the areas of SSTF / CPW so as to eliminate the need for clearing or modification of these endangered ecological communities.

6 Conclusion

Overall, the planning proposal for rezoning this land to proposed zone R5 (Large Lot Residential) as presented in Figure 6, has responded well to the ecological, riparian and bushfire constraints present on the site. Retention of the core SSTF vegetation area, use of adequate riparian setbacks and development restrictions, and the incorporation of perimeter roads around the nodes of development (and other bushfire protection measures) should enable future subdivision activity to occur which respects the current environmental values in the area.

Consideration should be given to ensuring the best ecological outcomes for the site through the potential to either enter into biobank arrangements or potentially bio-certifying the LEP amendment. Additionally, approving designated building envelopes at subsequent subdivision stages will ensure the greatest retention of existing vegetation. Incorporating good bushfire design measures into future subdivision layouts will minimise or potentially eliminate the need for vegetation loss or modification to improve bushfire safety levels.



LEGEND

- SITE BOUNDARY
- EXISTING TOWN LOTS
- SUBJECT TO SEPARATE PLANNING PROPOSAL
- PROPOSED ASHW LOTS
- INDICATIVE ROAD ACCESS

Conceptual Development Areas

Project: Eltons Road Silverdale
Date: 18th January 2012

Project No: 10-031W
Client: Wollondilly Shire Council

Taylor Brammer Landscape Architects Pty Ltd
26 Moore Street / PO Box 3064 Austinmer NSW
2515
Tel: +61 2 4267 5088 Fax: +61 2 4267 4826
Email: southcoast@taylorbrammer.com.au



Figure 6: Conceptual Development Area

References

Keith, D (2004). Ocean Shores to Desert Dunes: The Native Vegetation of New South Wales and the Australian Capital Territory. NSW Department of Environment and Conservation, Hurstville.

NSW NPWS (2002) Vegetation Mapping of the Cumberland Plain. NPWS Hurstville.

NSW PBP (2006). NSW Rural Fire Service “Planning for Bushfire Protection” Guidelines 2006.

WLEP (2011) Wollondilly Local Environment Plan

WDCP (2011) Wollondilly Development Control Plan.

Appendix A: Likelihood of Occurrence Tables

Based on the results of the NSW Atlas of Wildlife / Bionet Atlas and Commonwealth Protected Matters Search Tools, an assessment of likelihood of occurrence was made for each threatened and migratory species identified from the database searches. Five terms for the likelihood of occurrence of species are used in this report. This assessment was based on database or other records, presence or absence of suitable habitat, features of the proposal site, results of the field survey and professional judgement. The terms for likelihood of occurrence are defined below:

- “yes” = the species was or has been observed on the site
- “likely” = a medium to high probability that a species uses the site
- “potential” = suitable habitat for a species occurs on the site, but there is insufficient information to categorise the species as likely to occur, or unlikely to occur
- “unlikely” = a very low to low probability that a species uses the site
- “no” = habitat on site and in the vicinity is unsuitable for the species.

<i>Scientific Name</i>	<i>Common Name</i>	<i>Habitat</i>	<i>TSC Status</i>	<i>EPBC Status</i>	<i>Likelihood of Occurrence</i>
Flora Species					
<i>Ancistrachne maidenii</i>		Small sprawling or creeping grass found on moist creek banks. Rare plant found from few locations	V		Unlikely
<i>Caladenia tessellata</i>	Thick Lip Spider Orchid	Old records known from Sydney area. Generally found on grassy sclerophyll woodland or clay loam or sandy loam soils.	E	V	Unlikely
<i>Cryptostylis hunteriana</i>	Leafless Tongue Orchid	No apparent habitat preferences, occurs in swamp heath and woodland. Large populations associated with Scribbly Gum (<i>E. sclerophylla</i>) and Black She-Oak (<i>Allocasuarina littoralis</i>).	V	V	Unlikely

Ecology and Bushfire Constraints – Silverdale Combined Properties

<i>Scientific Name</i>	<i>Common Name</i>	<i>Habitat</i>	<i>TSC Status</i>	<i>EPBC Status</i>	<i>Likelihood of Occurrence</i>
<i>Cynanchum elegans</i>	White Flowered Wax Plant	On the edge of dry rainforest vegetation and littoral rainforest, Forest Red Gum (<i>E. tereticornis</i>) open woodland	E	E	Unlikely
<i>Dillwynia tenuifolia</i>		Castlereagh Ironbark Forest to Castlereagh Scribbly Gum Woodland.	V	V	Unlikely
<i>Epacris purpurascens</i> var <i>purpurascens</i>		Restricted to coastal zone around Sydney where it is uncommon. The species inhabits damp forest and grows on sands, shales or rocky sites.	V	-	Unlikely
<i>Eucalyptus benthamii</i>	Camden White Gum, Nepean River Gum	Very restricted occurrences in Bents Basin SCA, Southern Blue Mountains and south around Camden.	V	V	Potential
<i>Grevillea juniperina</i> subsp. <i>juniperina</i>	Juniper-leaved Grevillea	Grows on reddish clay to sandy soils derived from Wianamatta Shale and Tertiary alluvium (often with shale influence), typically containing lateritic gravels.	V	-	Potential
<i>Haloragis exalata</i> subs <i>exalata</i> var <i>exalata</i>	Square Raspwort	Known from 4 widely scattered localities in NSW, requires shaded and damp situations in riparian habitat			Unlikely
<i>Lepidium hyssopifolium</i>	Basalt Pepper Grass, Aromatic Pepper Cress	Appears to respond to disturbance, occurs in a variety of habitats including woodland with grassy understorey.	E	E	Unlikely
<i>Pimelea spicata</i>	Spiked Rice Flower	Occurs on undulating topography on substrates derived from Wianamatta Shale in areas of Cumberland Plain Woodland Vegetation Community.	E	E	Unlikely
<i>Pomaderris brunnea</i>	Brown Pomaderris	Found in very limited areas around the Colo, Nepean and Hawkesbury River Areas, including around Bargo. Found in association with several <i>Eucalyptus amplifolia</i> , <i>Angophora floribunda</i> , <i>Acacia parramatensis</i> . Found in moist woodland or forest on clay and alluvial soils of flood plains and creeklines.	V	V	Unlikely
<i>Pterostylis saxicola</i>	Sydney Plains Greenhood	Restricted to Western Sydney, most commonly found in small pockets of	E	E	Unlikely

Ecology and Bushfire Constraints – Silverdale Combined Properties

<i>Scientific Name</i>	<i>Common Name</i>	<i>Habitat</i>	<i>TSC Status</i>	<i>EPBC Status</i>	<i>Likelihood of Occurrence</i>
		shallow soil in depressions on sandstone rock shelves above cliff lines.			
<i>Thelymitra sp Kangaloon</i>	Kangaloon Sun Orchid	Grows in high altitude swamps around Robertson	E	CE	Unlikely
Ecological Communities					
Cumberland Plain Woodland		Woodland community occurring on shale derived soils throughout low rainfall areas of western Sydney.	CE	CE	Yes
Shale/Sandstone Transition Forest		Occurs at the edges of the Cumberland Plain, where clay soils from the shale rock intergrade with soils from sandstone, or where shale caps overlay sandstone (DECC 2009).	E	CE	Yes

<i>Scientific Name</i>	<i>Common Name</i>	<i>Habitat</i>	<i>TSC Status</i>	<i>EPBC Status</i>	<i>Likelihood of Occurrence</i>
Fauna Species					
Amphibians					
<i>Heleioporus australiacus</i>	Giant Burrowing Frog	Found in heath, woodland and open forest with sandy soils and will travel several hundred metres to creeks to breed.	V	V	Unlikely
<i>Litoria aurea</i>	Green and Golden Bell Frog	Large permanent freshwater wetlands, with dense stands of reeds.	E1	V	Unlikely
<i>Litoria raniformis</i>	Growling Grass Frog, Southern Bell Frog	Usually found in or around permanent or ephemeral Black Box/Lignum/Nitre Goosefoot swamps, Lignum/Typha swamps and River Red Gum swamps or billabongs along floodplains and river valleys. They are also found in irrigated rice crops, particularly	E	V	Unlikely

Ecology and Bushfire Constraints – Silverdale Combined Properties

Scientific Name	Common Name	Habitat	TSC Status	EPBC Status	Likelihood of Occurrence
		where there is no available natural habitat			
<i>Mixophyes iteratus</i>	Giant Barred Frog	Forage and live amongst deep, damp leaf litter in rainforests, moist eucalypt forest and nearby dry eucalypt forest, at elevations below 1000 m.	E1	E	Unlikely
<i>Pseudophryne australis</i>	Red-Crowned Toadlet	A localised species that appear to be largely restricted to the immediate vicinity of suitable breeding habitat. Usually found as small colonies scattered along ridges coinciding with the positions of suitable refuges near breeding sites. Occurs in open forests, mostly on Hawkesbury and Narrabeen Sandstones.	V	-	Potential
Birds					
<i>Anthochaera phrygia</i>	Regent Honeyeater	Inhabits dry open forest and woodland, particularly Box-Ironbark woodland, and riparian forests of River Sheoak. Regent Honeyeaters inhabit woodlands that support a significantly high abundance and species richness of bird species. These woodlands have significantly large numbers of mature trees, high canopy cover and abundance of mistletoes.	CE	E	Unlikely
<i>Botaurus poiciloptilus</i>	Australasian Bittern	Boggy marsh, wetland margins.	V	-	Unlikely
<i>Callocephalon fimbriatum</i>	Gang-gang Cockatoo	Occurs within a variety of forest and woodland types.	V	-	Potential
<i>Calyptorhynchus lathami</i>	Glossy Black-Cockatoo	She-oaks in forests, woodlands, timbered watercourses.	V	-	Potential
<i>Ephippiorhynchus asiaticus</i>	Black-necked Stork	Associated with tropical and warm temperate terrestrial wetlands, estuarine and littoral habitats, and occasionally woodlands and grasslands floodplains. Forages in fresh or saline waters up to 0.5m deep, mainly in open fresh waters, extensive sheets of shallow	E1	-	Unlikely

Ecology and Bushfire Constraints – Silverdale Combined Properties

Scientific Name	Common Name	Habitat	TSC Status	EPBC Status	Likelihood of Occurrence
		water over grasslands or sedgeland, mangroves, mudflats, shallow swamps with short emergent vegetation and permanent billabongs and pools on floodplains.			
<i>Ixobrychus flavicollis</i>	Black Bittern	Occurs in both terrestrial and estuarine wetlands generally in areas of permanent water and dense vegetation.	V	-	Unlikely
<i>Lathamus discolor</i>	Swift Parrot	Breeds in Tasmania, but winters on mainland in diverse timbered habitats, including forests, woodlands, plantations, banksias, street trees and gardens.	E1	E	Unlikely
<i>Lophoictinia isura</i>	Square-tailed Kite	Diverse habitats from woodlands to timbered watercourses.	V	M	Potential
<i>Melanodryas cucullata</i>	Hooded Robin	Drier eucalypt forests, woodlands and scrubs with fallen logs and debris.	V	-	Unlikely
<i>Ninox strenua</i>	Powerful Owl	Pairs occupy large, probably permanent home ranges in forests to woodlands. Nest in large hollow.	V	-	Potential
<i>Pyrrholaemus saggitatus</i>	Speckled Warbler	Patchy distribution throughout south-eastern Queensland, the eastern half of NSW and into Victoria. The Speckled Warbler lives in a wide range of Eucalyptus dominated communities that have a grassy understorey, often on rocky ridges or in gullies. Typical habitat would include scattered native tussock grasses, a sparse shrub layer, some eucalypt regrowth and an open canopy.	V	-	Unlikely
<i>Rostratula benghalensis australis</i>	Australian Painted Snipe	Well-vegetated shallows and margins of wetlands, dams, sewerage ponds, wet pastures, marshy areas, open timber.	E1	V	Unlikely
<i>Stagonopleura guttata</i>	Diamond Firetail	Found in grassy eucalypt woodlands, including Box-Gum	V	-	Unlikely

Ecology and Bushfire Constraints – Silverdale Combined Properties

Scientific Name	Common Name	Habitat	TSC Status	EPBC Status	Likelihood of Occurrence
		Woodlands and Snow Gum (<i>Eucalyptus pauciflora</i>) Woodlands. Also occurs in open forest, mallee, Natural Temperate Grassland, and in secondary grassland derived from other communities.			
<i>Tyto novaehollandiae</i>	Masked Owl	Associated with forest with sparse, open, understorey, typically dry sclerophyll forest and woodland and especially the ecotone between wet and dry forest, and non forest habitat. Known to utilise forest margins and isolated stands of trees within agricultural land and heavily disturbed forest where its prey of small and medium sized mammals can be readily obtained.	V	-	Unlikely
Invertebrates					
<i>Meridolum corneovirens</i>	Cumberland Plain Land Snail	Primarily inhabits Cumberland Plain Woodland (an endangered ecological community). This community is a grassy, open woodland with occasional dense patches of shrubs.	E1	-	Potential
Mammals					
<i>Chalinolobus dwyeri</i>	Large-eared Pied Bat	Uncommon but observed in wet and dry eucalypt forests.	V	V	Unlikely
<i>Dasyurus maculatus maculatus</i> (<i>SE mainland population</i>)	Spotted-tailed Quoll	Occurs in wide variety of habitats in large remnants. Dens in tree hollows, hollow log or rock crevice.	V	E	Unlikely
<i>Miniopterus schreibersii oceanensis</i>	Eastern Bentwing-bat	Forages above the canopy and eats mostly moths. Roosts in caves, old mines, road culverts.	V	-	Potential
<i>Mormopterus norfolkensis</i>	Eastern Freetail-bat	Evidence suggests that the species depends on hollows and tree fissures for roosting sites.	V	-	Potential

Ecology and Bushfire Constraints – Silverdale Combined Properties

<i>Scientific Name</i>	Common Name	Habitat	TSC Status	EPBC Status	Likelihood of Occurrence
<i>Myotis adversus</i>	Large-footed Myotis	A range of habitats close to water from lakes, small creeks to large lakes and mangrove lined estuaries.	V	-	Potential
<i>Petaurus australis</i>	Yellow-bellied Glider	This species is restricted to tall mature forests, preferring productive tall open sclerophyll forests with a mosaic of tree species including some that flower in winter. Large hollows within mature trees are required for shelter, nesting and breeding	V	-	Unlikely
<i>Petrogale penicillata</i>	Brush-tailed Rock-wallaby	Rocky areas of sclerophyll forest of inland and subcoastal southeastern Australia.	E1	V	Unlikely
<i>Potorous tridactylus tridactylus</i>	Long-nosed Potoroo (SE mainland)	Known from coastal heathy woodland but also occurs in rainforest, wet sclerophyll and coastal wallum. Dense cover for shelter adjacent to open areas for foraging.	V	V	Unlikely
<i>Pseudomys novaehollandiae</i>	New Holland Mouse	In NSW, the New Holland Mouse is known from Royal National Park, Kangaroo Valley, Kuringai Chase NP and Port Stephens to Evans Head.		V	Unlikely
<i>Pteropus poliocephalus</i>	Grey-headed Flying-fox	Roosts in large camps in Botanic Gardens.	V	V	Potential
<i>Scoteanax rueppellii</i>	Greater Broad-nosed Bat	Moist gullies in mature coastal forests or rainforests. Roosts in hollow tree trunks and branches.	V	-	Unlikely
Reptiles					
<i>Hoplocephalus bungaroides</i>	Broad-headed Snake	Occur under large exfoliating slabs of sandstone and rock crevices in areas of undisturbed bushland, usually on tops of cliffs.	E1	V	Unlikely
Fish					

Ecology and Bushfire Constraints – Silverdale Combined Properties

<i>Scientific Name</i>	Common Name	Habitat	TSC Status	EPBC Status	Likelihood of Occurrence
<i>Macquaria australasica</i>	Macquarie Perch	The natural geographical range of the Macquarie Perch is thought to have been confined to the Murray Darling R. System, north of the Great Divide, including Vic., NSW and the ACT (there are no confirmed records from Qld or SA). They also occur in some coastal rivers of NSW, including the Shoalhaven and Hawkesbury Rivers and also in some of Sydney's water supply dams.		E	Unlikely
<i>Prototroctes maraena</i>	Australian Grayling	On mainland Australia, this species has been recorded from rivers flowing E and S of the main dividing ranges, It is absent from the inland Murray-Darling system. It occurs widely in Tas. And is known from the northern, eastern and southern coastal river drainages with occasional reports from the W coast.		V	Unlikely
Migratory Birds					
<i>Apus pacificus</i>	Fork-tailed Swift	Utilises low to very high airspace over varied habitat from rainforest to semi-desert. Foragers ahead of summer storms.		M	Unlikely
<i>Ardea alba</i>	Great Egret	A common and widespread species that utilises any suitable permanent or temporary habitat. Inhabits wetlands and flooded pastures, dams, estuarine mudflats, mangroves and reefs.		M	Potential
<i>Ardea ibis</i>	Cattle Egret	Forages in moist pasture with tall grass as well as shallow open wetlands and margins. Also utilises mudflats.		M	Potential
<i>Gallinago hardwickii</i>	Latham's Snipe	Occupies low vegetation around wetlands in shallows, sedges, reeds, heaths salt marsh and irrigated crops.		M	Unlikely
<i>Haliaeetus leucogaster</i>	White-bellied Sea-Eagle	Established pairs usually maintain a territory in coastal areas or flooded inland swamps, lagoons and floodplains. Also often occur		M	Unlikely

Ecology and Bushfire Constraints – Silverdale Combined Properties

Scientific Name	Common Name	Habitat	TSC Status	EPBC Status	Likelihood of Occurrence
		far inland along major rivers.			
<i>Hirundapus caudacutus</i>	White-throated Needletail	Occupy high open spaces of sky above a variety of habitats including oceans. Often fly ahead of unsettled weather preceding thunderstorms.		M	Unlikely
<i>Merops ornatus</i>	Rainbow Bee-eater	Occurs in open country in a variety of habitat including open woodland, open forest, semi-arid scrub, grasslands, clearings in more wooded areas and farmland. Nests within tunnels dug into loamy soil in clearings, paddocks or road cuttings.		M	Unlikely
<i>Monarcha melanopsis</i>	Black-faced Monarch	Occurs in a range of habitats including rainforests, mangroves, forests and woodlands. A summer migrant to the south.		M	Unlikely
<i>Myiagra cyanoleuca</i>	Satin Flycatcher	Favours dense wet sclerophyll forest during the breeding season and mangrove, coastal heath, woodland and forests outside of the breeding season. A summer breeding migrant to south eastern Australia.		M	Unlikely
<i>Rhipidura rufifrons</i>	Rufous Fantail	A summer breeding migrant in the south east of Australia. Occurs in rainforest as well as dense wet eucalypt forest, paperbark forests, mangrove swamps and riverside vegetation. Occupies open country during summer migration.		M	Unlikely

Appendix B: Flora and Fauna Species List

Flora Species

Scientific Name	Common Name
<i>Acacia binervia</i>	Coast Myall
<i>Acacia brownei</i>	Heath Wattle
<i>Acacia decurrens</i>	Black Wattle
<i>Acacia parramattensis</i>	Sydney Green Wattle
<i>Allocasuarina littoralis</i>	Black She-oak
<i>Aristida ramosa</i>	Purple Wiregrass
<i>Aristida vagans</i>	Three-awn Speargrass
<i>Axonopus fissifolius</i>	Narrow-leaved Carpet-grass
<i>Briza minor</i>	Lesser Quaking-grass
<i>Bursaria spinosa</i>	Sweet Bursaria
<i>Cheilanthes sieberi</i>	Rock Fern
* <i>Chloris gayana</i>	Rhodes Grass
<i>Convolvulus erubescens</i>	Blushing Bindweed
* <i>Conyza bonariensis</i>	Flax-leaf Fleabane
<i>Corymbia eximia</i>	Yellow Bloodwood
<i>Corymbia maculata</i>	Spotted Gum
<i>Cynodon dactylon</i>	Couch
<i>Daviesia ulifolia</i>	Gorse Bitter-pea
<i>Dichondra repens</i>	Kidney Weed
<i>Drosera peltata</i>	Sundew
<i>Eleocharis sphacelata</i>	
<i>Eragrostis leptostachya</i>	Paddock Lovegrass
<i>Eucalyptus crebra</i>	Narrow-leaved Ironbark
<i>Eucalyptus eugenioides</i>	Thin-leaved Stringybark
<i>Eucalyptus punctata</i>	Grey Gum
<i>Eucalyptus tereticornis</i>	Forest Red Gum
<i>Euchiton sphaericus</i>	Cudweed
<i>Glycine clandestinum</i>	Glycine
<i>Goodenia hederacea</i> var. <i>hederacea</i>	Ivy Goodenia
<i>Hibbertia diffusa</i>	Wedge Guinea Flower
<i>Hypericum gramineum</i>	Small St John's Wort
* <i>Hypochoeris radicata</i>	Cat's-ear
<i>Juncus</i> sp.	Rush
<i>Kunzea ambigua</i>	Tick Bush
<i>Lomandra filiformis</i> subsp. <i>filiformis</i>	Wattle Mat-rush

<i>Lomandra multiflora</i> subsp. <i>multiflora</i>	Many-flower Mat-rush
<i>Microlaena stipoides</i> var. <i>stipoides</i>	Weeping Grass
<i>Panicum simile</i>	Two-colour Panic
<i>Pelargonium inodorum</i>	
<i>Pimelea linifolia</i> subsp. <i>linifolia</i>	Slender Rice-flower
<i>Plantago lanceolata</i>	Ribwort
<i>Pomax umbellata</i>	Pomax
<i>Pratia purpurascens</i>	Whiteroot
<i>Ranunculus</i> sp.	Buttercup
* <i>Senecio madagascariensis</i>	Fireweed
* <i>Sida rhombifolia</i>	Paddy's Lucerne
<i>Syncarpia glomulifera</i>	Turpentine
<i>Themeda australis</i>	Kangaroo Grass
* <i>Trifolium repens</i>	White Clover
<i>Wahlenbergia gracilis</i>	Slender Bluebell
<p>Note: This list includes a broad list of opportunistic flora records within the site. It does not represent a detailed inventory of all species that occur throughout the study area.</p> <p>* denotes exotic species</p>	

Fauna Species

Scientific Name	Common Name
<i>Pseudechis porphyriacus</i>	Red Bellied Black Snake
<i>Physignathus lesueurii lesueurii</i>	Eastern Water Dragon
<i>Psephotus haematonotus</i>	Red Rumped Parrot
<i>Calyptorhynchus funereus</i>	Yellow Tailed Black Cockatoo
<i>Cacatua roseicapilla</i>	Galah
<i>Cacatua sanguinea</i>	Corella
<i>Cacatua galerita</i>	Sulphur Crested Cockatoo
* <i>Capra hircus</i>	Goat
* <i>Vulpes vulpes</i>	Fox



HEAD OFFICE

Suite 4, Level 1
2-4 Merton Street
Sutherland NSW 2232
T 02 8536 8600
F 02 9542 5622

SYDNEY

Level 6
299 Sussex Street
Sydney NSW 2000
T 02 9993 0566
F 02 9993 0573

ST GEORGES BASIN

8/128 Island Point Road
St Georges Basin NSW 2540
T 02 4443 5555
F 02 4443 6655

CANBERRA

Level 2
11 London Circuit
Canberra ACT 2601
T 02 6103 0145
F 02 6103 0148

NEWCASTLE

Suite 17, Level 4
19 Bolton Street
Newcastle NSW 2300
T 02 4910 0125
F 02 4910 0126

NAROOMA

5/20 Canty Street
Narooma NSW 2546
T 02 4476 1151
F 02 4476 1161

COFFS HARBOUR

35 Orlando Street
Coffs Harbour Jetty NSW 2450
T 02 6651 5484
F 02 6651 6890

ARMIDALE

92 Taylor Street
Armidale NSW 2350
T 02 8081 2681
F 02 6772 1279

MUDGEES

Unit 1, Level 1
79 Market Street
Mudgee NSW 2850
T 02 4302 1230
F 02 6372 9230

PERTH

Suite 1 & 2
49 Ord Street
West Perth WA 6005
T 08 9227 1070
F 08 9322 1358

WOLLONGONG

Suite 204, Level 2
62 Moore Street
Austinmer NSW 2515
T 02 4201 2200
F 02 4268 4361

GOSFORD

Suite 5, Baker One
1-5 Baker Street
Gosford NSW 2250
T 02 4302 1220
F 02 4322 2897



ANNEXURE B

ABORIGINAL HERITAGE & NON-INDIGENOUS HERITAGE ASSESSMENT

ARTEFACT HERITAGE CONSULTANTS

Proposed rezoning at Silverdale, NSW

Aboriginal Heritage Due Diligence Assessment and Preliminary Non-Indigenous Heritage Assessment

Report to Planning Ingenuity

February 2012

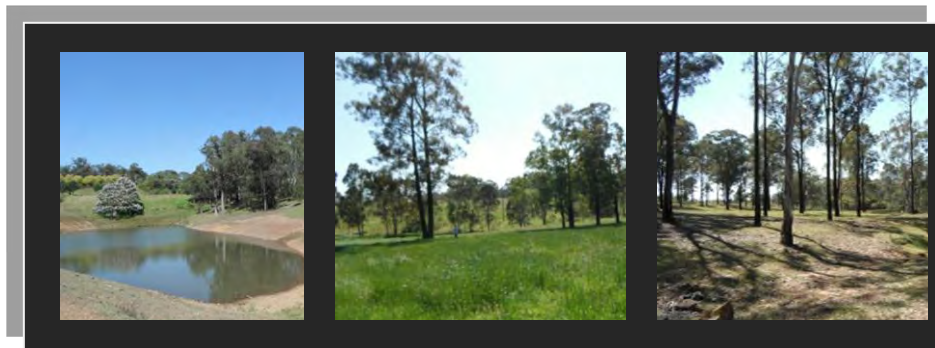

Artefact Heritage Services
ABN 73 144 973 526

Lvl 1 716 New South Head Rd
Rose Bay NSW 2029
PO BOX 772 Rose Bay
NSW Australia 2029
+61 2 9025 3958
+61 2 9025 3990

office@artefact.net.au
www.artefact.net.au



Contents

1.0 Introduction and Background	1
1.1 Background	1
1.2 The study area	1
1.3 The proposal	1
1.4 Report authorship	3
1.5 Aboriginal consultation.....	3
2.0 Environment and Context	4
2.1 Vegetation and resources	4
2.2 Hydrology	4
3.0 Survey Methodology.....	5
3.1 Background	5
3.2 Field methods	5
4.0 Preliminary Non-Indigenous Heritage Assessment.....	6
4.1 Background	6
4.2 Relevant legislation.....	6
4.3 Register listings	10
4.4 Local historical context	13
4.5 History of the study area.....	13
4.6 Heritage significance and impact assessment	15
5.0 Due Diligence Assessment for Aboriginal Heritage.....	16
5.1 Due diligence regulation.....	16
5.2 Legislative context.....	16
5.3 Aboriginal occupation and site types	17
5.4 Registered Aboriginal sites in the local area – AHIMS search.....	19



5.5	Previous archaeological work	20
5.6	Recent land disturbance	21
5.7	Site prediction.....	21
5.8	Site Survey Observations	22
5.9	Assessment of archaeological potential	23
6.0	Recommendations	24
6.1	Recommendations for non-Indigenous heritage	24
6.2	Recommendations for Aboriginal heritage	24
7.0	References.....	26

Figures

Figure 1: The study area in its local context.....	2
Figure 2: The study area outlined in red (Source for background - GoogleEarth.com).	2
Figure 3: The study area (outlined in red) in relation to LEP heritage items I226 and I227 (Wollondilly LEP Heritage Map Sheet HER_006B).....	12
Figure 4: Detail from 1900 Parish map of Warragamba (Parish Maps Preservation Project)	14
Figure 5: Topographic map, map series 1970-1997, study area outlined in red (Lands and Property Information Division).....	14
Figure 6: AHIMS registered sites in the vicinity of the study area with approximate location of study area marked with the red circle.	20
Figure 7: Disturbed area – dam to the east of the nursery.	22
Figure 8: Disturbed area – Market garden in the southwestern section of the study area.	22
Figure 9: Sandstone platform along Beres Creek.	22



Figure 10: Area of minimal disturbance to the south of Beres Creek..... 22

Figure 11: Archaeological potential (low potential – clear, moderate potential – shaded blue) 23

Tables

Table 1: Site type frequencies based on AHIMS data 19



1.0 Introduction and Background

1.1 Background

Artefact Heritage Services was commissioned by Planning Ingenuity to conduct a due diligence assessment of Aboriginal heritage and a preliminary assessment of non-Indigenous heritage to support a rezoning application for land at Silverdale, New South Wales.

The aim of this study is to assess preliminary heritage values across the study area and to recommend if further work would be required at later stages of the planning process. This study is preliminary in nature and does not fulfill the requirements of an Aboriginal Archaeological Survey Report, or a Statement of Heritage Impacts for non-Indigenous Heritage.

1.2 The study area

The study area consists of fifteen properties located in an area bounded by Eltons Road to the south and Taylors Road to the east (Figures 1 and 2). The study area is currently rural-residential with uses varying from market gardens, a nursery, grazing land, and relatively undisturbed bush land.

1.3 The proposal

The purpose of this Planning Proposal is to rezone the site to an R5 zoning to enable its future redevelopment for rural residential lots with a minimum lot size of 4,000m². Currently the LEP requires minimum 16 hectare lots. I have been instructed that it is anticipated that future development of the site may proceed in a manner similar to that depicted in the “Conceptual Development Areas Plan” prepared by Taylor Brammer Landscape Architects Pty Ltd submitted separately and which I have reviewed. It is estimated that the Planning Proposal would yield a maximum of 193 allotments however this may be reduced through analysis of constraints on an individual allotment basis.

Proposed rezoning at Silverdale, NSW



Figure 1: The study area in its local context.

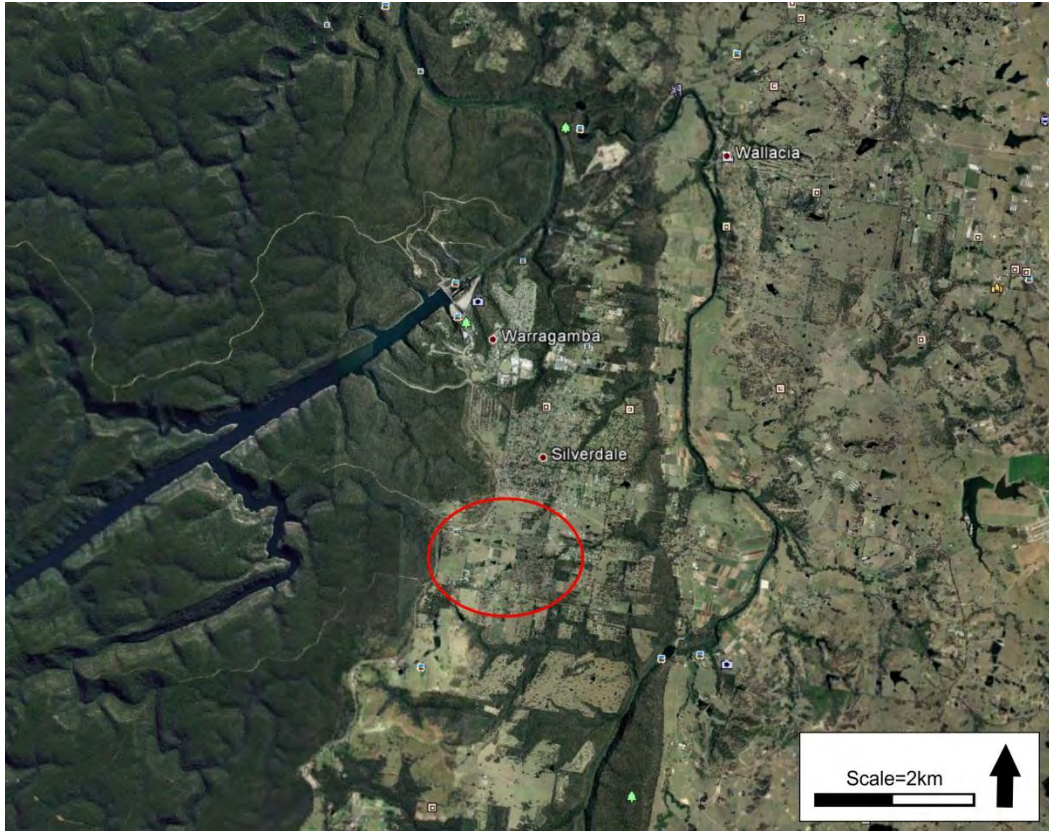

Figure 2: The study area outlined in red (Source for background - GoogleEarth.com).





1.4 Report authorship

Dr Sandra Wallace and Adele Anderson wrote this report. The assistance of Jeff Mead from Planning Ingenuity is acknowledged in supplying relevant plans and other information.

1.5 Aboriginal consultation

Limited Aboriginal consultation was undertaken during this study. According to EPA policy and guidelines comprehensive Aboriginal consultation is required if Aboriginal objects or places are likely to be impacted. The aim of this preliminary assessment is to ascertain the likelihood of Aboriginal sites being impacted and recommend if further archaeological work and Aboriginal consultation will be required at a later stage of the planning process.

Tharawal Local Aboriginal Land Council (TLALC) and Cubbitch Barta Native Title Claimants Corporation (CBNTCC) were contacted about the project and invited to attend a site survey. TLALC was unavailable to attend on the day. Glenda Chalker from CBNTCC accompanied the archaeologists on the site visit. Copies of the draft report for this study were forwarded to the Aboriginal groups for their comments. TLALC did not provide comment. CBNTCC comments are attached in Appendix 1 of this report.



2.0 Environment and Context

2.1 Vegetation and resources

Most of the study area is now cleared, however, the remnant vegetation falls into the vegetation communities of Shale/Sandstone Transition Forest and Cumberland Plain Woodland. The Shale/Sandstone Transition Forest with a high sandstone influence is dominated by Grey Gum (*Eucalyptus punctate*) and Narrow-leaved Ironbark (*E. crebra*), while common smaller tree species include Black She-Oak (*Allocasuarina littoralis*), Turpentine (*Syncarpia glomulifera*), Narrow-leaved Geebung (*Persoonia linearis*) and Green Wattle (*Acacia decurrens*). Shrub species include Tick Bush (*Kunzea ambigua*), Blackthorn (*Bursaria spinosa*), and Dogwood (*Jacksonia scoparia*). Where the Shale/Sandstone Transition Forest has a low sandstone influence, Grey Gum and Narrow-leaved Ironbark occur less frequently, and the canopy is dominated by Forest Red Gum (*Eucalyptus tereticornis*). Small trees include Black She-Oak, Green Wattle and gum trees (*Eucalyptus spp.*). The ground is covered in various fern and grass species.

The Cumberland Plains Woodland community includes two sub-categories: Shale Hills Woodland and Shale Plains Woodland. Both are present in the vicinity of the study area. The Shale Hills Woodland is dominated by Grey Box (*Eucalyptus moluccana*) and Forest Red Gum, with an understory of commonly occurring Eucalyptus species and Lightwood (*Acacia implexa*). The Shale Plains Woodland is also dominated by Grey Box and Forest Red Gum, with Thin-leaved Stringbark (*E. eugenioides*), Narrow-leaved Ironbark, and Spotted Gum (*Corymbia maculate*) occurring less frequently (DEC 2004).

Aboriginal people were highly mobile hunter-gatherers utilising different landform units and resource zones. Different resources may have been available seasonally, necessitating movement or trade (Attenbrow 2010: 78). Aboriginal people hunted kangaroo and wallaby and snared possums for food and skins.

2.2 Hydrology

Beres Creek runs through the northeastern section of the study area. There are several dams present and it is possible that these have reduced the flow of ephemeral watercourses. Approximately three kilometres to the west is a large creek, Monkey Creek, and immediately beyond is Warragamba Dam. Around one kilometre to the south-east is the Nepean River and Bents Basin.



3.0 Survey Methodology

3.1 Background

The site survey was undertaken on October 19 2011, by Sandra Wallace and Adele Anderson (Artefact), and Glenda Chalker (CBNTCC). The survey was not comprehensive, but aimed to identify areas of Aboriginal archaeological potential that may require further investigation. The survey also investigated the study area for evidence of non-Indigenous archaeological remains. Several sections of the study area were not visited during the site survey as access was not available at that time. These were Lot 2 DP562249, Lot 3 DP 734828, Lot 48 DP 236542, Lot 50 DP 236542 and Lot 51 DP 236542. A desktop assessment has been completed for these areas.

3.2 Field methods

The study area was traversed in a vehicle, with pedestrian survey conducted over some areas that had undergone minimal disturbance or which included landscape units that were likely to have archaeological potential. The survey also involved an assessment of the levels of disturbance across the survey area and did not include a detailed examination of the area for Aboriginal sites.

A photographic record was kept for the study area. Photographs were taken of significant landscape features and representative areas of disturbance or archaeological potential.



4.0 Preliminary Non-Indigenous Heritage Assessment

4.1 Background

This non-Indigenous heritage assessment was required to make a preliminary assessment of the impact of the proposed development on two heritage listed sites in the vicinity of the study area: Silverdale Progress Hall and All Saints Anglican Church, as well as to assess the potential for non-Indigenous archaeological remains within the study area.

4.2 Relevant legislation

There are several pieces of State legislation that are relevant to the current study. A summary of these Acts and the implications for the proposed development follow.

The Heritage Act 1977

The *NSW Heritage Act 1977* is the primary piece of heritage legislation affording protection to items of state heritage significance and archaeological material and deposits in New South Wales. Under the Act, 'items of environmental heritage' include places, buildings, works, relics, moveable objects and precincts identified as significant based on historical, scientific, cultural, social, archaeological, architectural, natural or aesthetic values. Items of identified heritage afforded a level of State Significance are listed on the NSW State Heritage Register and are given automatic protection under the Act against any activities that may damage an item or affect its heritage significance.

If works are proposed within a State Heritage Register listed site consent is required under Section 60 of the Heritage Act. An exemption may be granted by the Heritage Branch.

The Heritage Act protects 'relics' as defined by the Act and such 'relics' can include archaeological material. Section 139[1] of the Act states that:

A person must not disturb or excavate any land knowingly or having reasonable cause to suspect that the disturbance or excavation will or is likely to result in a relic being discovered, exposed, damaged or destroyed unless the disturbance or excavation is carried out in accordance with an excavation permit.



Permits to excavate 'relics' which are not within an area listed on the State Heritage Register are issued by the Heritage Council under Section 140 of the Act. Exceptions may be made under certain conditions and would be approved in writing by the Heritage Council.

NSW S170 Heritage and Conservation Register.

The *NSW Heritage Act 1977* also requires all government agencies to identify and manage heritage assets in their ownership and control. Under Section 170 of the Act, government instrumentalities must establish and keep a register which includes all items of environmental heritage listed on the State Heritage Register, an environmental planning instrument or which may be subject to an interim heritage order that are owned, occupied or managed by that government body. Under Section 170A of the *Heritage Act 1977*, all government agencies must also ensure that all items entered on its register are maintained with due diligence in accordance with State Owned Heritage Management Principles approved by the NSW Minister for Planning & Infrastructure on advice of the NSW Heritage Council. These principles serve to protect and conserve the heritage significance of identified sites, items and objects and are based on relevant NSW heritage legislation and statutory guidelines.

The Environmental Planning and Assessment Act 1979

The *Environmental Planning and Assessment Act 1979* establishes the framework for cultural heritage values to be formally assessed in the land use planning and development consent process. The Act requires that environmental impacts are considered prior to land development; this includes impacts on cultural heritage items and places as well as archaeological sites and deposits. The Act also requires that Local Governments prepare planning instruments (such as Local Environmental Plans, Development Control Plans) in accordance with the Act to provide guidance on the level of environmental assessment required. The current study area falls within the boundaries of the Wollondilly LGA and is subject to the Wollondilly Local Environmental Plan [LEP] (2011).

Wollondilly LEP 2011

The Wollondilly LEP aims to conserve the environmental and cultural heritage of Wollondilly. The relevant clauses of the LEP are as follows:

(2) Requirement for consent

Development consent is required for any of the following:



(a) demolishing or moving any of the following or altering the exterior of any of the following (including, in the case of a building, making changes to its detail, fabric, finish or appearance):

(i) a heritage item,

(ii) an Aboriginal object,

(iii) a building, work, relic or tree within a heritage conservation area,

(c) disturbing or excavating an archaeological site while knowing, or having reasonable cause to suspect, that the disturbance or excavation will or is likely to result in a relic being discovered, exposed, moved, damaged or destroyed,

(d) disturbing or excavating an Aboriginal place of heritage significance,

(e) erecting a building on land:

(i) on which a heritage item is located or that is within a heritage conservation area, or

(ii) on which an Aboriginal object is located or that is within an Aboriginal place of heritage significance,

(f) subdividing land:

(i) on which a heritage item is located or that is within a heritage conservation area, or

(ii) on which an Aboriginal object is located or that is within an Aboriginal place of heritage significance.

(3) When consent not required

However, development consent under this clause is not required if:

(a) the applicant has notified the consent authority of the proposed development and the consent authority has advised the applicant in writing before any work is carried out that it is satisfied that the proposed development:

(i) is of a minor nature or is for the maintenance of the heritage item, Aboriginal object,



Aboriginal place of heritage significance or archaeological site or a building, work, relic, tree or place within the heritage conservation area, and

(ii) would not adversely affect the heritage significance of the heritage item, Aboriginal object, Aboriginal place, archaeological site or heritage conservation area, or

(4) Effect of proposed development on heritage significance

The consent authority must, before granting consent under this clause in respect of a heritage item or heritage conservation area, consider the effect of the proposed development on the heritage significance of the item or area concerned. This subclause applies regardless of whether a heritage management document is prepared under subclause (5) or a heritage conservation management plan is submitted under subclause (6).

(5) Heritage assessment

The consent authority may, before granting consent to any development:

- (a) on land on which a heritage item is located, or
- (b) on land that is within a heritage conservation area, or
- (c) on land that is within the vicinity of land referred to in paragraph (a) or (b),

require a heritage management document to be prepared that assesses the extent to which the carrying out of the proposed development would affect the heritage significance of the heritage item or heritage conservation area concerned.

(7) Archaeological sites

The consent authority must, before granting consent under this clause to the carrying out of development on an archaeological site (other than land listed on the State Heritage Register or to which an interim heritage order under the Heritage Act 1977 applies):

- (a) notify the Heritage Council of its intention to grant consent, and
- (b) take into consideration any response received from the Heritage Council within 28 days after the



notice is sent.

Implications of Legislation

The implications of the legislation for the study area are that under the *NSW Heritage Act 1977* any item listed on the statutory registers is protected from direct harm, or harm to its heritage significance. The Wollondilly LEP also deals explicitly with cases where development occurs or is proposed in the vicinity of a heritage site or item. In this case it should be ensured that the development does not impact on the heritage significance of the item or place. This includes considerations of 'fabric, settings and views'.

Legislation also protects archaeological relics. If relics are to be disturbed a consent permit may be required, and would be issued by the Heritage Council under Section 140 of the *Heritage Act 1977*. Exceptions may be made under certain conditions and would be approved in writing by the Heritage Council.

4.3 Register listings

Statutory registers provide legal protection for heritage items. In NSW the *Heritage Act 1977*, and the *Environmental Planning and Assessment Act 1979* give legal protection. The State Heritage Register, the S170 registers, and heritage schedules of Local Environment Plans are statutory listings. Places on the National Heritage List are protected under the *Environment Protection and Biodiversity Conservation Act 1999*.

Register of the National Estate

The Register of the National Estate is a list of natural, Indigenous and historic heritage places throughout Australia. It was originally established under the *Australian Heritage Commission Act 1975*. Under that Act, the Australian Heritage Commission entered more than 13,000 places in the register. Following amendments to the *Australian Heritage Council Act 2003*, the Register of the National Estate (RNE) was frozen on 19 February 2007, which means that no new places can be added, or removed. The Register will continue as a statutory register until February 2012.

No items within the study area are listed on the Register of the National Estate.



National Heritage List

The National Heritage List has been established to list places of outstanding heritage significance to Australia. It includes natural, historic and Indigenous places that are of outstanding national heritage value to the Australian nation.

No items within the study area are listed on the Register of the National Estate.

Section 170 Registers

Section 170 requires government agencies to keep a Register of heritage items. A S.170 Register is a record of the heritage assets owned or managed by a NSW government agency. Relevant s170 registers were checked (Sydney Water, RTA, Railcorp).

No s170 register listings were found within the study area.

The State Heritage Register

The State Heritage Register (SHR) is a list of places and objects of particular importance to the people of NSW and is administered by the Heritage Branch of the Department of Planning. The register lists a diverse range of over 1,500 items, in both private and public ownership. To be listed, an item must be deemed to be of heritage significance for the whole of NSW.

No items within the study area are listed on the SHR.

Wollondilly Local Environmental Plan (LEP) 2011

The Wollondilly LEP includes a list and maps of items/sites of heritage significance within the LGA. No heritage items are located within the study area. Two items, All Saints Anglican Church and the Silverdale Progress Hall, are located around 300m to the north-east of the study area.

Suburb	Item	Address	Lot/DP	Within the study area?	Significance	LEP Item number
Silverdale	All Saints Anglican Church	1980 Silverdale Road	Lot 1, DP 928151	No	Local	1 226
Silverdale	Silverdale Progress Hall	1984 Silverdale Road	Lot 1, DP 221710	No	Local	1 227



Figure 3: The study area (outlined in red) in relation to LEP heritage items I226 and I227 (Wollondilly LEP Heritage Map Sheet HER_006B)

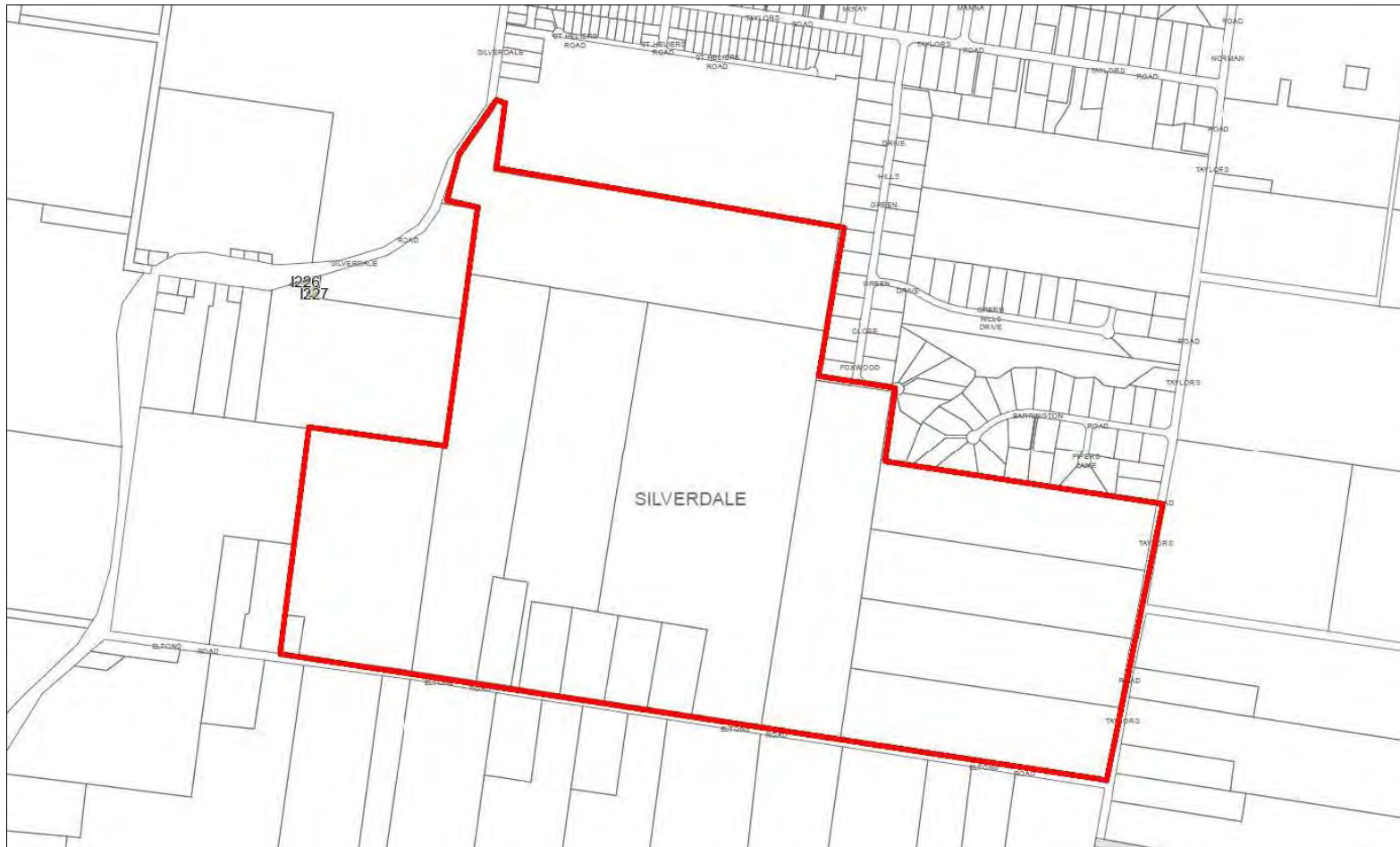



4.4 Local historical context

Silverdale was originally part of a larger area known as Mulgoa Forest, which also incorporated present-day Orangeville and Werombi, and began as a small farming community. By 1900 a public school had been established on Silverdale Road, south of the study area. Many early landowners were graziers and ran sheep and cattle on their land, while fruit growing was increasingly common during the early twentieth century (*Sydney Morning Herald [SMH]* 20/11/1915:17). During the late nineteenth and early twentieth centuries, Silverdale residents agitated for the extension of the railway to Wallacia, to encourage the growth of the area as a fruit and vegetable growing community (*SMH* 13/7/1914:12). The rail link was never constructed and Silverdale continued to develop slowly. Since the 1960s, subdivision and residential development has increased, but around the outskirts of the township the rural environment is maintained with many properties functioning as market gardens or horse studs.

4.5 History of the study area

The majority of the study area was originally part of 640 acres purchased by Lieutenant Colonel Thomas Shadforth in the mid-nineteenth century, while the south-west corner of the study area was part of land owned by John Dudley. Shadforth's house, Ravenswood, was situated on land to the east of the study area. There are no known structures within the study area during the nineteenth century.

Topographic maps from map series 1970-1997 show number of structures within the study area (Figure 5). Almost all of these structures correspond with the buildings currently present on each property. On the site of the present-day Sunset Nursery, three structures on the topographic map do not correspond to the current buildings. However, they are situated in the same location as the current house, swimming pool, and other buildings, and it is unlikely that archaeological remains of the earlier buildings survive.

Three structures on the 'Greylands' property (45 Eltons Road), do not correspond to the current structures, but are located in the same area as the present-day buildings and water tanks. It is not known how old these previous structures were, and it is unlikely that archaeological remains of the buildings have survived. The majority of the dams now present within the study area are visible in the 1970-1997 topographic map, though it is not known when they were first built.



Figure 4: Detail from 1900 Parish map of Warragamba (Parish Maps Preservation Project)

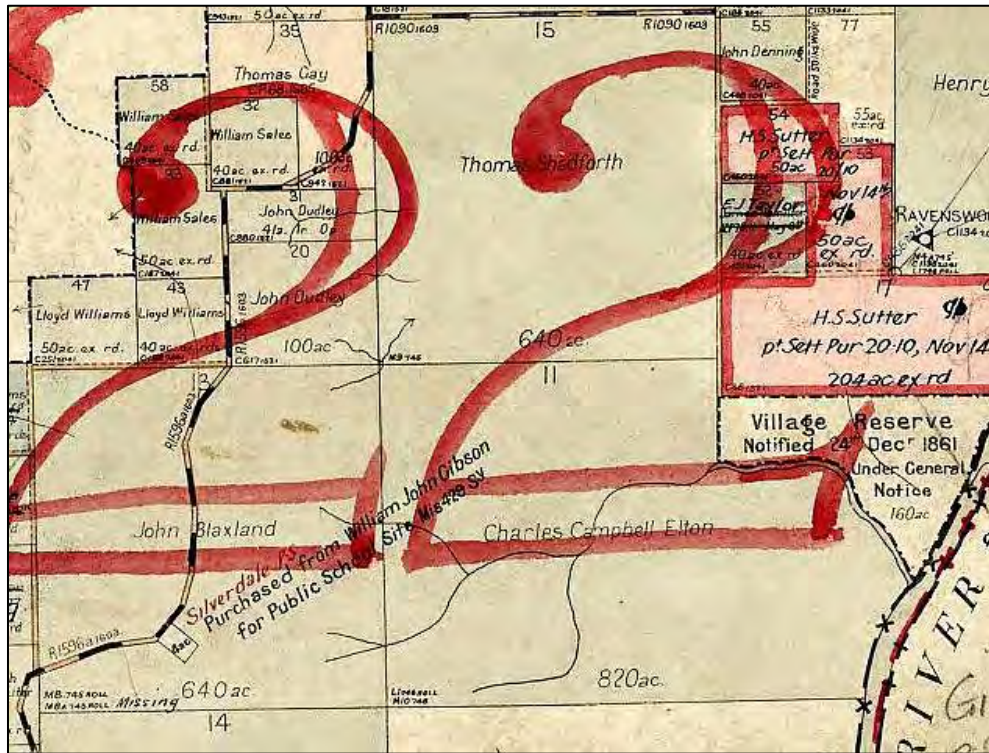
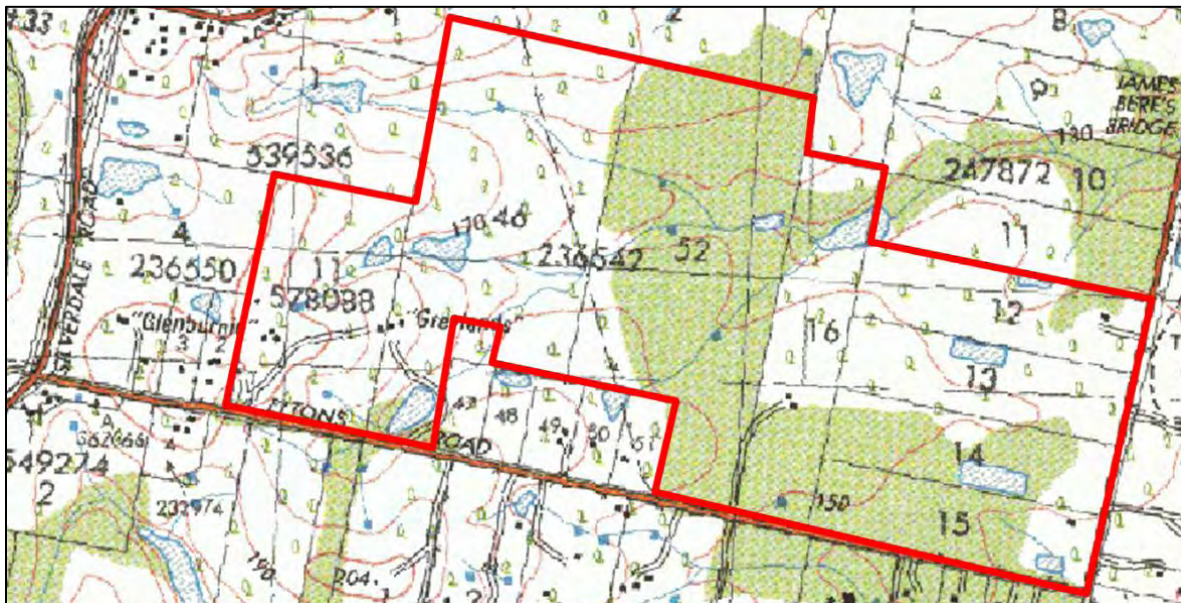

Figure 5: Topographic map, map series 1970-1997, study area outlined in red (Lands and Property Information Division).





4.6 Heritage significance and impact assessment

Statement of significance: All Saints Anglican Church and Silverdale Progress Hall

The heritage listed All Saints Anglican Church and Silverdale Progress Hall both possess local historical, aesthetic and social significance as early buildings that played an important role in the early development of the local community. Both buildings have continued to be used by the community until the present day, and are representative of similar buildings in country towns and villages throughout NSW.

Assessment of heritage impact

The church and progress hall are located around 300m north-west of the study area, fronting Silverdale Road. They are situated on a hill that overlooks the study area, but they are oriented away from the study area and views into the valley from the rear of the heritage buildings are screened by vegetation. The proposed development would therefore have no impacts on the heritage values of the church and progress hall.

No unlisted items of heritage value were located within the study area during the site visit. Preliminary investigations have found that it is unlikely that non-Indigenous archaeological remains are present within the study area.



5.0 Due Diligence Assessment for Aboriginal Heritage

5.1 Due diligence regulation

The Due Diligence Code of Practice for the Protection of Aboriginal Objects in New South Wales was introduced in October 2010 by the Department of Environment, Climate Change and Water (now the Environment Protection Authority). The aim of the guidelines is to assist individuals and organisations to exercise due diligence when carrying out activities that may harm Aboriginal objects and to determine whether they should apply for consent in the form of an Aboriginal Heritage Impact Permit (AHIP).

A due diligence assessment should take reasonable and practicable steps to ascertain whether there is a likelihood that Aboriginal sites will be disturbed or impacted during the proposed development. If it is assessed that sites exist or have a likelihood of existing within the development area and may be impacted by the proposed development further archaeological investigations may be required, along with an Aboriginal Heritage Impact Permit (AHIP). If it is found to be unlikely that Aboriginal sites exist within the study area and the due diligence assessment has been conducted according to the Code of Practice work may proceed without an AHIP.

5.2 Legislative context

Due Diligence assessments must be conducted within the context of NSW heritage legislation. Two principal pieces of legislation provide automatic statutory protection for Aboriginal heritage and the requirements for its management in New South Wales. These are the *National Parks and Wildlife Act 1974* as amended (2010) and the *Environmental Planning and Assessment Act 1979*.

National Parks & Wildlife Act (1974)

The *National Parks & Wildlife Act 1974* provides statutory protection for all Aboriginal 'objects' (consisting of any material evidence of the Aboriginal occupation of NSW) under Section 90 of the Act, and for 'Aboriginal Places' (areas of cultural significance to the Aboriginal community) under Section 84.

Aboriginal objects are afforded automatic statutory protection in NSW whereby it is an offence to:

damage, deface or destroy Aboriginal sites without the prior consent of the Director-General of the National Parks and Wildlife Service [now the EPA].



The Act defines an Aboriginal 'object' as:

any deposit, object or material evidence (not being a handicraft for sale) relating to indigenous and non-European habitation of the area that comprises New South Wales, being habitation before or concurrent with the occupation of that area by persons of non-Aboriginal European extraction, and includes Aboriginal remains'.

The Act was recently amended (2010) with the legislative structure for seeking permission to impact on heritage items modified. An s.90 permit is now the only Aboriginal Heritage Impact Permit (AHIP) available and may only be granted by the EPA if the conditions of the 'due diligence guidelines', and/or an 'archaeological investigation' have been met. The penalties and fines for damaging or defacing an Aboriginal object have also increased

Environmental Planning & Assessment Act (1979)

In contrast with the NPW Act, the EP&A Act is designed more specifically to cater for heritage issues within the context of new development projects and is closely linked with the process of preparing environmental impact studies. This act has three main parts of direct relevance to Aboriginal cultural heritage. Namely, Part III which governs the preparation of planning instruments, Part IV which relates to development assessment process for local government (consent) authorities and Part V which relates to activity approvals by governing (determining) authorities.

5.3 Aboriginal occupation and site types

Aboriginal people have lived in the Sydney area for more than 20,000 years. The oldest securely dated site in the greater Sydney region is 14,700 years before present (yBP), which was recorded in a rock shelter at Shaw's Creek (Nanson et al 1987). Evidence of Aboriginal occupation has been found dated to 50-60,000 yBP at Lake Mungo in NSW, so it is likely that Aboriginal people have lived in the Sydney region for even longer than indicated by the oldest recorded dates we have at present. The archaeological material record provides evidence of this long occupation, but also provides evidence of a dynamic culture that has changed through time.

Material traces of this long occupation exist throughout the landscape and are known as Aboriginal sites. The primary site types that may be present in the study area are as follows.



- Stone Artefacts – Flaked and ground stone artefacts are the most common trace of Aboriginal occupation in the Sydney region. Aboriginal people used particular techniques to flake stone and these changed over time. The approximate age of a tool can often be diagnosed by the way that it was made. Stone artefacts are most often found in scatters that may indicate an Aboriginal campsite was once present. Stone tools in the Sydney region are most often made from raw materials known as silcrete, tuff and quartz. These are all easily flaked and form sharp edges, which can be used for cutting or barbing spears. It is possible that stone artefacts, either on the surface, or buried, exist within the study area.
- Rock shelters with deposit – Rock shelters were used by Aboriginal people for habitation, rest places and as art or ceremonial sites. Deposits can build up on the floor of these shelters over time and bury traces of Aboriginal occupation. If these deposits are not disturbed, rock shelters can provide an intact stratigraphy that can tell us about the way Aboriginal occupation changed through time.
- Shell middens – Shell middens are remains of campsites in which the primary traces are shell and/or bones of fish. Shell middens are often found close to rivers or streams and are either along banks or within enclosed shelters. It is unlikely that shell midden material is present within the study area, as the nearby creeks would not have supported suitable shellfish species.
- Rock engravings/Rock art –Rock art of various forms has been recorded in New South Wales. Stencils, charcoal drawings, paintings and engravings are examples of the techniques used by Aboriginal people. Rock art is relatively rare, but is more common on sandstone geologies. Rock art or engravings may occur within the study area due, if suitable sandstone surfaces are present.
- Axe grinding grooves – Axe grinding grooves are created when axe blanks (often basalt cobbles) are shaped by rubbing the stone across an abrasive rock such as sandstone, often using water. Sharpening axes and other tools also forms them. Axe grinding grooves are often found on the banks of streams or rock pools. It is possible that axe grinding grooves are present in the southern portion of the study area, close to Beres Creek.
- Scarred trees – Aboriginal people practiced tree marking or scarring for a variety of reasons. Large scars are often the result of a tree being debarked for a canoe blank and smaller scars may have been the result of making shields or coolamons (storage vessels). Tree marking may have



been the result of ritual practices, or associated with burial. Scarred trees that remain today would be over 150 years old and the scar would retain certain characteristics that enable its identification as cultural. It is possible that scarred trees remain in the study area.

- Contact sites – Sites with evidence of early interaction between Aboriginal people and Europeans are known as contact sites. Artefacts found at contact sites may include flaked glass or ceramic. It is possible that contact sites may be located within the study area.
- Potential Archaeological Deposit (PAD) – Areas are classified as PADs if there is a likelihood of archaeological material existing below the ground surface or on the ground surface but obscured from view. An Aboriginal object does not need to be recorded for an area of PAD to be specified.

5.4 Registered Aboriginal sites in the local area – AHIMS search

A search of the Aboriginal Heritage Information Management System (AHIMS) was conducted on 14 October 2011. The search took in a 7.5km radius of the study area (Zone 56, Easting from 275000-282500 Northing from 6240000-6247500). Twenty-one registered Aboriginal sites were located in the search. One site was registered as restricted but is known to be within the Bents Basin area and not within the study area. No registered sites were located within the study area.

The majority of the registered sites are rock shelters with the majority of sites recorded to the south east of the study area in the southern portion of the Bents Basin State Recreation Area. Sixty per cent of the sites are rock shelter sites either with art, deposit or both. These are located a sandstone geology which is different to the shale/sandstone transition geology of the study area.

Table 1: Site type frequencies based on AHIMS data

Site Type	Frequency	Percentage
Open camp site	6	30
Shelter with art	6	30
Shelter with deposit	2	10
Shelter with art and deposit	4	20
Axe grinding groove	2	10



Figure 6: AHIMS registered sites in the vicinity of the study area with approximate location of study area marked with the red circle.

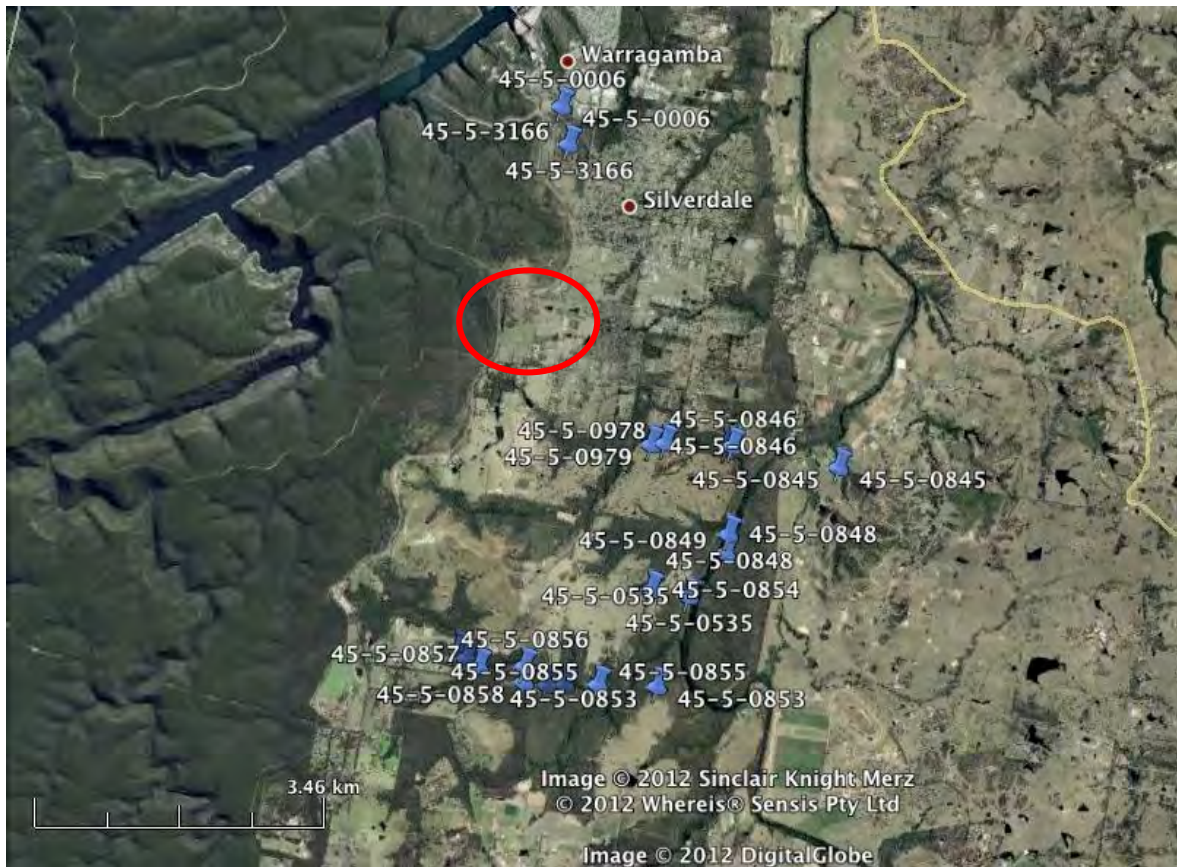

5.5 Previous archaeological work

Mary Dallas 1982 Bents Basin State Recreation Area – Archaeologist Mary Dallas conducted a site survey and assessment of the Bents Basin State Recreation Area (BBSRA) in order to determine the location of Aboriginal sites and advise on conservation strategies for significant areas. The BBSRA is a 391 hectare area that stretches between Wallacia and Camden and includes five kilometers of the Nepean River. It is located approximately two kilometers to the east of the study area. The BBSRA is predominantly located within sandstone geology, although a section in the northeast is Blacktown Soil landscape with clay loam soils.

Dallas identified 16 Aboriginal sites, 15 potential occupation sites and four isolated finds during the site survey. A number of highly significant art sites were located included several rock shelters containing charcoal drawings. A ground stone axe was also located, as were a number of grinding groove sites.

Dallas concluded that occupation sites were predominantly within the rock shelters on, or just below the



plateau and above the creeks that fed into the Nepean. Dallas further suggests that these shelters may have been used for summer occupation as they are exposed to strong southwesterly winds in winter which would have rendered them inhospitable.

Navin Officer 1994 Aboriginal Archaeology of Bushrangers Creek – Navin Officer Archaeological Resource Management conducted a primarily desktop assessment of Aboriginal archaeology within a 400ha parcel of land at Bushrangers Creek as part of a subdivision application. This area is directly to the south of the current study area, on the southern side of Eltons Road.

The desktop assessment concluded that it was highly likely that shelter and art sites remained within the study area. This was confirmed by a limited site visit in which three Aboriginal sites and several areas of potential archaeological deposit were located. It was further recommended that a comprehensive field survey of the area should be conducted.

5.6 Recent land disturbance

Most of the study area was cleared during the 19th century, and some damage to the soil surface has been caused by erosion and long-term grazing. Some areas have been disturbed through intensive market gardening and construction of buildings, sheds, a nursery and a number of large dams and water detention basins. However, a large portion of the study area has undergone little significant disturbance. The vegetated areas along the creek in the northern section of the study area are likely to be the least disturbed.

5.7 Site prediction

Based on the distribution of known Aboriginal sites provided by previous studies and an AHIMS register search; the types of landform units found in the study area; and the levels of subsurface disturbance within the study area, statements can be made about the likelihood of archaeological sites being present within the study area, and what they may constitute.

As the study area has remained largely undisturbed, it is probable that Aboriginal sites have survived. Stone artefacts or artefact scatters are the most likely site type to occur within the study area. As the study area is within a shale/sandstone transition geology it is unlikely that rock shelters will be located. Sites are most likely to be found near the creek through the central and northern portions of the study area.



5.8 Site survey observations

The study area varied from small rural lots with high disturbance levels (Figures 7 & 8) to larger agricultural lots with low levels of disturbance (Figures 9 & 10). It was noted that some vegetated areas such as Lot 13 DP247872 were disturbed with the vegetation being more recent regrowth; while some areas that had been cultivated were within high sensitivity land form units such as on a lower slope alongside a creek line or ephemeral watercourse. This was the case with the northern portion of Lot 2 DP 734838.

Some areas which were assessed as having a moderate archaeological potential were noted to have a low ground surface visibility as a result of grass and leaf litter cover. Any existing arefacts at the surface would therefore have been obscured.

Figure 7: Disturbed area – dam to the east of the nursery.



Figure 8: Disturbed area – Market garden in the southwestern section of the study area.



Figure 9: Sandstone platform along Beres Creek.



Figure 10: Area of minimal disturbance to the south of Beres Creek.





5.9 Assessment of archaeological potential

Assessment of archaeological potential is based on several factors, such as the levels of ground disturbance, and the archaeological sensitivity of the landscape. Sections of the study area that have been subject to intensive farming, or landscape modification, or that are within low sensitivity landforms such as steep slopes, have been assessed as having a low archaeological potential. Areas which are less disturbed or are on high sensitivity landforms, such as terraces or lower hill slopes close to water are assessed as having a moderate archaeological potential. Figure 11 shows preliminary archaeological potential mapping. The areas shown in blue which are assessed as having a moderate archaeological potential will require further archaeological investigation.

Figure 11: Archaeological potential (low potential – clear, moderate potential – shaded blue)

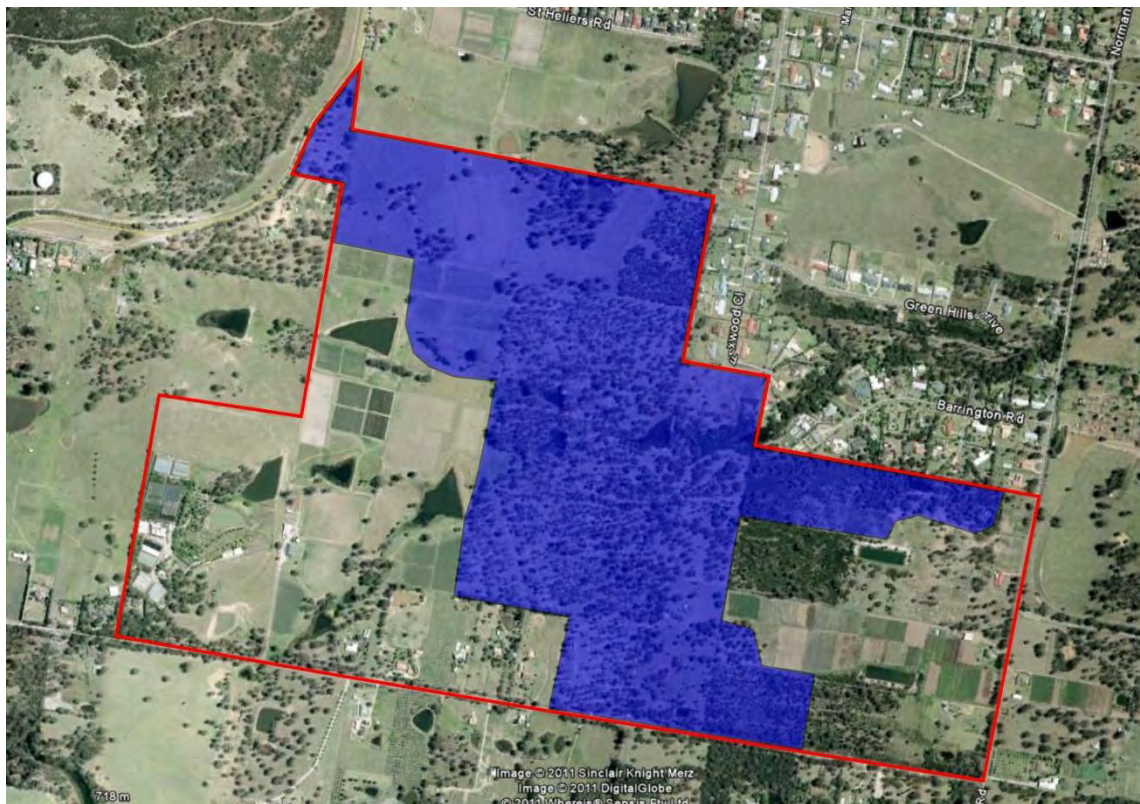



6.0 Recommendations

6.1 Recommendations for non-Indigenous heritage

The following recommendations are based on consideration of:

- Statutory requirements under the *NSW Heritage Act 1977* as amended and other statutory and regulatory instruments;
- The results of the background research, site survey and assessment;
- The likely impacts of the proposed rezoning.

And the findings of the study:

- There are no non-Indigenous heritage listed sites within the study area;
- Two heritage listed sites within the vicinity of the study area will not be impacted by the proposed rezoning;
- There is a low potential for non-Indigenous archaeological remains to be present within the study area.

It is therefore recommended that:

- There are no known non-Indigenous heritage constraints within the study area;
- Further non-Indigenous heritage assessment or Statements of Heritage Impacts are not recommended;
- If unanticipated non-Indigenous heritage items or archaeological remains are identified within the study area, further assessment will be required to determine heritage significance.

6.2 Recommendations for Aboriginal heritage

The following recommendations are based on consideration of:

- Statutory requirements under the *National Parks and Wildlife Act 1974* as amended;
- The requirements of the Environment Protection Authority Due Diligence guidelines;
- The results of the background research, site survey and assessment;
- The likely impacts of the proposed rezoning.



And the findings of the study:

- There are no recorded Aboriginal sites within the study area;
- The central portion of the study area has been assessed as having a moderate archaeological potential.

It is therefore recommended that:

- A further Aboriginal heritage assessment shall be prepared at development application stage for subdivision of the site covering the sections of the study area that have been assessed as having a moderate archaeological potential;
- There are no known Aboriginal heritage constraints on sections of the study area assessed as having a low archaeological potential and therefore no further Aboriginal archaeological work will be required in these areas;
- If unanticipated Aboriginal objects are located within the areas of low potential during future works further archaeological investigation and consents may be required;
- A copy of the Due Diligence Assessment should be forwarded to TLALC and CBNTCC for their comments.



7.0 References

- Attenbrow, V. 2010 *Sydney's Aboriginal Past: Investigating the archaeological and historical records*. UNSW Press.
- Dallas, Mary. 1982 *An Archaeological Survey of the Bents Basin State Recreation Area for a Plan of Management*. Report to National Parks and Wildlife.
- Jo McDonald CHM Pty Ltd. 2005. *Archaeological salvage excavation of site CG1 (NPWS #45-5-2648), at the corner of Charles and George Streets, Parramatta, NSW*. Report for Meriton Apartments.
- Nanson, G.C., Young, R.W., & Stockton, E.D. 1987. Chronology and palaeoenvironment of the Cranebrook Terrace (near Sydney) containing artefacts more than 40,000 years old. *Archaeology in Oceania*, 22 (2): 72-78.
- Navin Officer 1994 *Aboriginal Archaeological Component – Bushrangers Creek Local Environmental Study and Development Control Plan*. Report to Purdon Associates.
- DEC (Department of Environment and Conservation). 2004. *The Native Vegetation of the Nattai and Bargo Reserves*. Conservation Assessment and Data Unit, Conservation Programs and Planning Branch, Metropolitan Environmental Protection and Regulation Division, Department of Environment and Conservation.



ANNEXURE C

WATER AND SEWER SERVICING REPORT

MARTENS CONSULTING ENGINEERS

Planning Ingenuity Pty Ltd

Water and Sewer Servicing

Proposed Rezoning – Silverdale, NSW



ENVIRONMENTAL



WATER



WASTEWATER



GEOTECHNICAL



CIVIL



PROJECT
MANAGEMENT



P1103173JR01V02

February 2012

Copyright Statement

Martens & Associates Pty Ltd (Publisher) is the owner of the copyright subsisting in this publication. Other than as permitted by the Copyright Act and as outlined in the Terms of Engagement, no part of this report may be reprinted or reproduced or used in any form, copied or transmitted, by any electronic, mechanical, or by other means, now known or hereafter invented (including microcopying, photocopying, recording, recording tape or through electronic information storage and retrieval systems or otherwise), without the prior written permission of Martens & Associates Pty Ltd. Legal action will be taken against any breach of its copyright. This report is available only as book form unless specifically distributed by Martens & Associates in electronic form. No part of it is authorised to be copied, sold, distributed or offered in any other form.

The document may only be used for the purposes for which it was commissioned. Unauthorised use of this document in any form whatsoever is prohibited. Martens & Associates Pty Ltd assumes no responsibility where the document is used for purposes other than those for which it was commissioned.

Limitations Statement

The sole purpose of this report and the associated services performed by Martens & Associates Pty Ltd is to undertake an assessment of water and sewer demands and serviceability in accordance with the scope of services set out in the contract / quotation between Martens & Associates Pty Ltd and Planning Ingenuity (hereafter known as the Client). That scope of works and services were defined by the requests of the Client, by the time and budgetary constraints imposed by the Client, and by the availability of access to the site.

Martens & Associates Pty Ltd derived the data in this report primarily from a number of sources which may include for example site inspections, correspondence regarding the proposal, examination of records in the public domain, interviews with individuals with information about the site or the project, and field explorations conducted on the dates indicated. The passage of time, manifestation of latent conditions or impacts of future events may require further examination / exploration of the site and subsequent data analyses, together with a re-evaluation of the findings, observations and conclusions expressed in this report.

In preparing this report, Martens & Associates Pty Ltd may have relied upon and presumed accurate certain information (or absence thereof) relative to the site. Except as otherwise stated in the report, Martens & Associates Pty Ltd has not attempted to verify the accuracy or completeness of any such information (including for example survey data supplied by others).

The findings, observations and conclusions expressed by Martens & Associates Pty Ltd in this report are not, and should not be considered an opinion concerning the completeness and accuracy of information supplied by others. No warranty or guarantee, whether express or implied, is made with respect to the data reported or to the findings, observations and conclusions expressed in this report. Further, such data, findings and conclusions are based solely upon site conditions, information and drawings supplied by the Client etc. in existence at the time of the investigation.

This report has been prepared on behalf of and for the exclusive use of the Client, and is subject to and issued in connection with the provisions of the agreement between Martens & Associates Pty Ltd and the Client. Martens & Associates Pty Ltd accepts no liability or responsibility whatsoever for or in respect of any use of or reliance upon this report by any third party.

© February 2012
 Copyright Martens & Associates Pty Ltd
 All Rights Reserved

Head Office
 6/37 Leighton Place
 Hornsby, NSW 2077, Australia
 ACN 070 240 890 ABN 85 070 240 890
Phone: +61-2-9476-9999
 Fax: +61-2-9476-8767
 Email: mail@martens.com.au
 Web: www.martens.com.au

Document and Distribution Status							
Author(s)		Reviewer(s)		Project Manager		Signature	
Michael Dumas		Gray Taylor, Dr Daniel Martens		Gray Taylor			
Revision No.	Description	Status	Release Date	Document Location			
				File Copy	MA Library	Client	
1	Draft Report	Draft	25.10.11	1E, 1P, 1H	1H	1P	
2	Final	Draft	16.02.11	1E, 1P, 1H	1H	1P	

Distribution Types: F = Fax, H = hard copy, P = PDF document, E = Other electronic format. Digits indicate number of document copies.

All enquiries regarding this project are to be directed to the Project Manager.

Contents

1 INTRODUCTION	5
1.1 Overview	5
1.2 Scope of Assessment	5
1.2.1 Water	5
1.2.2 Sewer	6
1.3 Overview of the Rezoning Proposal	6
2 WATER SUPPLY	8
2.1 Potable Water Demand	8
2.2 Fire Fighting Demand	9
2.3 Existing Available Reticulated Services	10
2.4 Preliminary Network Modelling	10
2.4.1 Modelling aims and methodology	10
2.4.2 Results	12
2.5 Water Recommendations	12
3 SEWER SERVICING.....	14
3.1 Sewage Generation	14
3.2 Recommendations	15
4 REFERENCES	18
5 ATTACHMENT A – SITE PLANS	19
6 ATTACHMENT B – SYDNEY WATER PRESSURE AND FLOW INFORMATION	24
7 ATTACHMENT C – PIPES MODEL.....	29

1 Introduction

1.1 Overview

This services assessment has been prepared by Martens and Associates on behalf of Planning Ingenuity to support a proposed rezoning of several existing lots located at Silverdale Road, Eltons Road and Taylors Road, Silverdale, NSW. The lots considered in this study are as follows:

- Lot 2 D.P. 562249 – 2010 Silverdale Road.
- Lot 11 D.P. 578088 – 45 Eltons Road.
- Lots 1 and 2 D.P. 734838 – 71 and 95 Eltons Road.
- Lot 52 D.P. 236542 – 135 Eltons Road.
- Lots 12, 13, 14, 15 and 16 D.P. 247872 – 270, 290, 300 and 310 Taylors Road and 155 Eltons Road respectively.

A plan of the study area is provided in Attachment A.

This report summarises the preliminary assessment of potential water and sewerage services demands and opportunities to service the study area.

The study also briefly considers the impacts associated with a separate rezoning proposal located at Lot 300 D.P. 1076326 – 2054 Silverdale Road, adjacent to the northern part of the study area.

1.2 Scope of Assessment

1.2.1 Water

Scope of assessment with respect to water included the following:

1. Available Water Services

Determination of the nearest available water services as well as pressure and flow availability.

2. Demand Evaluation

Determine likely potable water demand and fire demand requirements for the proposed rezoned area based on likely lot sizes and yields.

3. Preliminary Network Modelling

Assessment of existing reticulated water network capacity to support estimated water demands of the proposed rezoned lots.

4. Recommendations

Provide recommendations to enable progression to more detailed water reticulation planning and design for water supply to the rezoned area.

1.2.2 Sewer

Scope of assessment with respect to sewer included the following:

1. Available Sewer Services

Determination of the nearest available sewer services.

2. Sewage Generation Evaluation

Determine likely sewage generation rates, including dry and wet weather flows, for the proposed rezoned area based on likely lot sizes and yields.

3. Recommendations

Provide recommendations to enable progression to more detailed sewer reticulation planning and design for sewer servicing of the rezoned area.

1.3 Overview of the Rezoning Proposal

We understand that the proposed rezoning is broadly described as follows:

1. Rezoning of the subject lots from Rural RU2 to Large Lot Residential R5 similar to existing residential sub-divisions to the north-east of the study area.
2. The study area could ultimately support 1 acre average lots (4,046 m²). Approximate available area for residential lots is approximately 78.1 ha of the total study area of 166.7 ha. This

takes into account areas of the site which are proposed to be public space / reserves due to existing vegetation, topographic and drainage constraints as well as proposed site road reserves. We note that the final lot sizes and yields may vary and depend on ultimate zoning and layout of any future sub-division.

3. Provision of road and drainage reserves and riparian management areas.
4. Provision of services including (but not necessarily limited to) reticulated water, sewer, telecommunications, electricity and gas.
5. Provision of stormwater drainage including treatment measures and outlets. The stormwater system would incorporate components for discharge quantity and quality control.

2 Water Supply

2.1 Potable Water Demand

Preliminary potable water demand estimates for the proposed rezoning area are based on preliminary lot yield estimates (Table 1). The study area was split into three (3) parts on the basis of ground level. The demand rates from the proposed rezoning of Lot 300 was included in the analyses for the purposes of determining the likely effects of this development on water supply to the study area.

Site plans in Attachment A show extents of demand areas used in preliminary modelling. Demands were estimated utilising default demand rates in accordance with the *Water Supply Code of Australia – Sydney Water Edition Version 2, WSA 03-2002-2.2*. Demand estimates are summarised in Table 2.

Table 1: Preliminary lot yield estimates.

Rezoning Area	Total Area (ha)	Lot Area (ha)	Lot Size (ha)	Lot Yield	Ground Level (mAHD)
A	86.07	42.48	0.4 ¹	108	<160
B	58.60	22.25	0.4 ¹	52	160 – 180
C	22.05	13.35	0.4 ¹	33	>180
Lot 300	26.62	14.00	0.1	140	138 – 190
Total	193.35	92.08	-	333	138 – 210

Notes: ¹: Average lot size in study area are 1 acre lots (4046 m²).

Table 2: Preliminary potable water demand estimates summary.

Rezoning Area	Max. Day Demand Rate (kL/d) ¹	Ave. Day Demand Rate (kL/d) ²	Max. Hour Demand Rate (L/s) ²	Max. Hour Demand Rate per Lot (L/s)
A	420.0	182.6	10.7	0.1
B	220.0	95.7	5.6	0.1
C	132.0	57.4	3.4	0.1
Lot 300	574.0	249.6	14.6	0.1
Total Study Area	772.0	585.2	34.3	0.1
Total Study Area plus Lot 300	1346.0	335.6	19.7	0.1

Notes: ¹. Based on 41 kL/ha/d for 1000 m² lots and 4 KL/lot/d for 1 acre lots (Table 2.1 SW ed. WSA 03-2002-2.2) ². Ratio Max hr / Max day = 2.2; Max day / Ave day = 2.3.

2.2 Fire Fighting Demand

Should a reticulated water supply be available, the following hydrant design requirements are noted for the land (Table 3).

Table 3: Site external hydrant minimum requirements (from Table 2.2 AS 2419 2005).

	Attack Hydrant Unassisted	Feed Hydrant Unassisted
Minimum flow rate (L/s)	10	10
Minimum Residual Pressure (m Head)	25	15
Max. hose length reach to all portions of building (m)	60	60
Minimum hose stream length (m)	10	10
Max. hose length connecting fire booster pump appliance to fire brigade booster assembly.	20	20

Based on the requirements of AS2419.1, all proposed lots would require a minimum of 1 operational hydrant within a minimum distance of 90 m if a reticulated supply were provided.

2.3 Existing Available Reticulated Services

Advice obtained from Sydney Water indicates that there are several existing water mains near to the study area (refer to site plans in Attachment A), detailed as follows:

1. 100 mm uPVC main in St Heliers Road (north of Lot 300 adjacent to study area).
2. 100 mm uPVC main in Foxwood Close.
3. 100 mm uPVC main in Taylors Road (north of existing lot 12 D.P. 247872).
4. 100 mm uPVC main on the eastern side of Silverdale Road (west of Lot 300 and north-west of study area).
5. Sydney Water has also indicated that there is a 375 mm main on the western side of Silverdale Road, however, it is not known if this main is a dedicated supply main or if connection to this main would be possible.

Mains pressure enquiries were lodged with Sydney Water for the first four locations noted above. Pressure enquiry locations and results are provided in Attachment A and B. Existing pressures are summarised as follows.

Table 4: Existing pressure and flow rates for existing mains near to study area.

Location	Maximum Pressure (m Head)	Minimum Pressure (m Head)	Maximum Permissible Flow (L/s)
100 mm main in St Heliers Road (a)	51	42	19 ¹
100 mm main in Foxwood Close (b)	75	63	14 ²
100 mm main in Taylors Road (c)	85	66	7 ³
100 mm main in Silverdale Road (d)	26	20	20 ⁴

Notes: ¹. Maximum flow rate given as 19 L/s and 17 m residual pressure head. ². Maximum flow rate given as 14 L/s and 4 m residual pressure head. ³. Maximum flow rate given as 7 L/s and 17 m residual pressure head. ⁴. Maximum flow rate given as 20 L/s and 4 m residual pressure head.

2.4 Preliminary Network Modelling

2.4.1 Modelling aims and methodology

The PIPES hydraulic model was used to assess the capacity of the existing reticulated services to support the proposed rezoning. For the

purposes of this report, the site was divided into demand rezoning areas on the basis of approximate ground level, with total system demand rates used in the model summarised in Table 5. Site plans in Attachment A show extents of demand areas used in preliminary modelling.

Scenarios that were considered in the modelling were as follows:

1. Scenario 1: Peak hourly demand, peak daily demand, average daily demand (averaged over 24 hours) and fire demand (taken to be 1 hydrant operating at 10 L/s plus average daily demand) for all study areas.
2. Scenario 2: As above, but with Rezoning Area C not included (i.e. site areas above 180 mAHD).

The following assumptions and calibrations were made for modelling purposes:

- o Existing 150 mm UPVC mains in St Heliers Road, Foxwood Close and Taylors Road will be available for connection to the site and retained in existing condition (flow rate deliverable and residual pressure). Individual mains representing all three possible mains connections points were used in the model.
- o 140 lots were included in Lot 300 to consider the likely impacts of this proposed development on the potable water supply to the study area.
- o A 100 mm main connecting 2044 Silverdale Road and 135 Eltons Road was included to allow all mains to supply the site demand. This assumes an easement would be temporarily available through 2044 Silverdale Road to allow connection to the southern part of the rezoning area from St Heliers Road.
- o Pressure in existing mains was adjusted to match rates specified by Sydney Water for certain flow rates.
- o Minimum mains residual pressure to be 5 m head.
- o Study areas were each supplied with a 150 mm UPVC main.
- o Fire hydrants were located at the most hydraulically disadvantaged points within rezoning areas.
- o Fire demand rates were assumed to be 10 L/s/hydrant.

- Minimum pressure head required for fire fighting was taken to be 25 m head (attack hydrant unassisted).

Table 5: Demand rates used in preliminary network modelling.

	Scenario 1	Scenario 2
Peak Hourly Demand (L/s)	34.28	28.31
Peak Daily Demand ¹ (L/s)	15.58	12.86
Average Daily Demand ¹ (L/s)	6.77	5.59
Fire Demand (attack hydrant) and Average Daily Demand (L/s)	16.77	15.59

Notes: ¹. Demand averaged over one day to give average demand in L/s.

2.4.2 Results

Results of preliminary network modelling are summarised in Table 6 below. Results indicate the following:

- Scenario 1: Average daily demand can be supplied, but flow rates and pressures are inadequate for peak and fire fighting demands.
- Scenario 2: All demands are met.

Table 6: Summary of results of preliminary network modelling.

	Able to be Supplied Using Existing Infrastructure (Y/N)	
	Scenario 1	Scenario 2
Peak Hourly Demand (L/s)	N	Y
Peak Daily Demand ¹ (L/s)	N	Y
Average Daily Demand ¹ (L/s)	Y	Y
Fire Demand and Average Daily Demand (L/s)	N	Y

2.5 Water Recommendations

Based on our preliminary network modelling, recommended water supply options for the site include:

Option 1 – Amplify Existing Services

If the entire site is to be serviced, then existing services will need to be amplified. This may include one or more of the following: (a) upgrade / additional supply network reticulation; (b) reservoir capacity augmentation; and (c) provision of water pressure booster system.

Option 2 – Build New Services

The site could be supplied with a new reservoir (around 665 KL would be required) and new supply reticulation. This is unlikely to be necessary given the outcomes of the preliminary network modelling.

Option 3 – Rainwater Harvesting

Individual dwellings could be serviced by a roof rainwater capture and storage system. Storage tanks in the order of 80-100 KL would be required at each dwelling site.

Option 4 – Part Site Serviced

Only part of the site is serviced (e.g. below say 180 mAHD) with the balance serviced by rainwater harvesting systems.

3 Sewer Servicing

3.1 Sewage Generation

Preliminary sewage generation rates have been estimated in accordance with the *Sewerage Code of Australia - Sydney Water Edition*, WSA-02-2002. Equivalent Population (EP) estimates and an assumed lot area breakdown are summarised in Table 7.

EP estimates were derived utilising default demand rates based on land-use type which was selected as for the water demand analyses. "Single Occupancy Lots" was thus selected from the available categories in WSA-02-2002.

A number of assumptions have been made in estimating sewer generation rates:

- Lot yields for the proposed rezoning area are as for potable water supply calculations (Section 2).
- 3.5 EP/dwelling has been adopted for the study area based on rates given in *Sewerage Code of Australia - Sydney Water Edition*, WSA-02-2002.
- The 1 in 2 year 1 hour storm rainfall intensity for Warragamba was used in calculating the Peak Wet Weather Flow (PWWF).

Table 7: Preliminary equivalent population (EP) estimates

	Study Area	Lot 300	Total
Total Area (ha)	166.72	26.62	193.34
Total Developable Area	78.12	14.00	92.12
Lot Size (ha)	0.4	0.1	-
Lot Yield	193	140	342
Equivalent Population¹	675.5	1050	1725.5

Notes: ¹. Based on 3.5 EP/lot. Table A1 WSA 02-2002-2.2.

EP's were used to derive sewage generation estimates (Table 8). The following is noted:

- The same Average Dry Weather Flow (ADWF) is obtained regardless of splitting the site into the study area and Lot 300 or

considering the study area and adjacent rezoning area as a whole.

- Splitting the study area into the study area and Lot 300 results in a slightly higher estimate of Peak Dry Weather Flow (PDWF) as compared to considering the study area as a whole.
- Splitting the study area into the study area and Lot 300 also gives a higher PWWF than considering the study area as a whole. PWWF has been adopted as the “Design Flow” for the study areas.
- “Design Flow” estimates are required for designing pipe networks and input to pump station designs. Design flow is the peak flow to be contained within a sewer system and is the sum of the following components.

$$\text{Design flow (PWWF)} = \text{PDWF} + \text{GWI} + \text{IIF}$$

where PDWF = d (peaking factor) * ADWF
 GWI = groundwater infiltration
 IIF = rainfall inflow and infiltration

Table 8: Sewage generation estimates for study area.

Rezoning Area	EP	ADWF (L/s)	PDWF “d” Factor	PDWF (L/s)	GWI	A _{eff} ¹	C	I	IIF	Design Flow (PWWF) (L/s)
Study Area	675.5	1.41	2.29	3.22	1.04	6.85	1	37.3	7.16	11.42
Lot 300	1050	2.19	3.26	7.14	0.17	3.41	1	46.5	4.44	11.75
Total Area	1725.5	3.59	-	10.36	1.21	-	-	-	-	23.17

Notes: ¹. Effective area taken to be 25% of site area.

3.2 Recommendations

The following comments / recommendations are made with respect to connection of the study area to the existing sewerage network servicing Silverdale:

- The nearest existing sewerage connection point to the study area is the existing 150 mm sewer main in St Heliers Road to the north of the study area. This main connects to another 150 mm main in Taylors Road. Preliminary analyses indicate that the load on the sewer main in Taylors Road is approximately 252 EP (72 lots at 3.5 EP/lot). WSA Sewerage Code WSA02-2002-2.2 (Sydney Water 2009) indicates that a 150 mm sewer main may service a maximum load of 600 EP. This would indicate that the main in Taylors Road may be able to accept an additional maximum

load of 348 EP from the site, subject to the size and existing load on the downstream sewer main (currently unknown). Given the above loading rate of 3.5 EP/lot, this equates to a maximum of 99 additional lots that may be serviced by the existing mains.

- From the above preliminary analyses, it is likely that lots from the proposed sub-division of Lot 300 to the north of the study area would utilise any existing spare capacity in the main on St Heliers Road rather than lots within the study area.
- Several options may be available for providing sewer services for lots in the study area. These are summarised in Table 9.
- Preliminary discussions with Sydney Water have indicated that no information, aside from that indicated above, regarding existing capacities of the sewer network (including mains, pumping stations and sewage treatment works) in the vicinity of the study area would be available until such time as the proposed rezoning is lodged with Council.

Table 9: Summary of sewerage options for study area.

Option	Comments
Connection to Sydney Water Sewer Network	Option would require sewer system to be built for the study area. Sewage Pump Station(s), wet weather storage well(s) and rising main(s) would be required to transfer flow from site to existing sewer system. Existing sewer network may require amplification to accept flows from the study area. This option is not likely to be available in the short-term.
Individual Pump-out System	Option require individual dwellings to have pump-out tanks and associated facilities. Capacity for pump-out contractor servicing local area to cater for additional dwellings is unknown. Option is possible in the short-term but expensive in the long-term. The system would also become redundant should the site be connected to Sydney Water sewer in the future.
Individual on-site septic tank with effluent disposal trenches	Option requires individual septic tanks and effluent disposal trenches for each dwelling. Option is possible although there is no opportunity for effluent re-use.
Individual on-site Aerated Wastewater Treatment Systems (AWTS) with effluent re-use fields	Option requires individual AWTS and effluent re-use fields on each lot. Option is possible for lots with greater than 2,000 m ² in area – subject to detailed site capability assessment. Option is considered to be sustainable in the long-term and offers opportunity for effluent re-use.
Communal sewerage network and on-site Sewage Treatment Plant (STP)	<p>Option requires the construction of site sewer system and on-site STP and on-site effluent storage tank and re-use field. Preliminary analyses indicate that approximately 8.7 ha of land would need to be dedicated to effluent re-use (on the basis of 193 lots in the study are producing 900 L effluent / lot / day – or 173.7 KL effluent / day total – and an application rate of 2 mm/day (clay soils). Effluent storage tank(s) would need to be 5.2 ML, based on total effluent load of 173.7 KL/day from the study area and a minimum of 30 days wet weather storage. It is also noted that this system could be amended to include a non-potable re-use system similar to Sydney Water’s system currently servicing Rouse Hill and Kellyville.</p> <p>Advantages of this option is that a reticulated sewer would be built for the site that could then be connected to a future Sydney Water reticulated sewer network. Disadvantages of this option include system construction costs compared with individual on-site sewage management, loss of land for the dedicated effluent re-use area and liability for maintaining sewerage reticulation, treatment and effluent re-use operations.</p>

4 References

Australian / New Zealand Standard 1547 (2000), *On-site domestic wastewater management*.

Australian Standard 2419.1 (2005), *Fire Hydrant Installations*.

Department of Local Government, NSW Environment Protection Authority, NSW Health Department, NSW Department of Land and Water Conservation and the NSW Department of Urban Affairs and Planning (1998), *Environment and Health Protection Guidelines, On-site Sewage Management for Single Households*.

NSW Department of Environment and Conservation (2004) *Environmental Guidelines – Use of Effluent by Irrigation*.

Water Services Association of Australia / Sydney Water (2009) *Water Supply Code of Australia WSA03-2002-2.2 Sydney Water Edition Version 2*.

Water Services Association of Australia / Sydney Water (2009) *Sewerage Code of Australia WSA02-2002-2.2 Sydney Water Edition Version 3*.

5 Attachment A – Site Plans

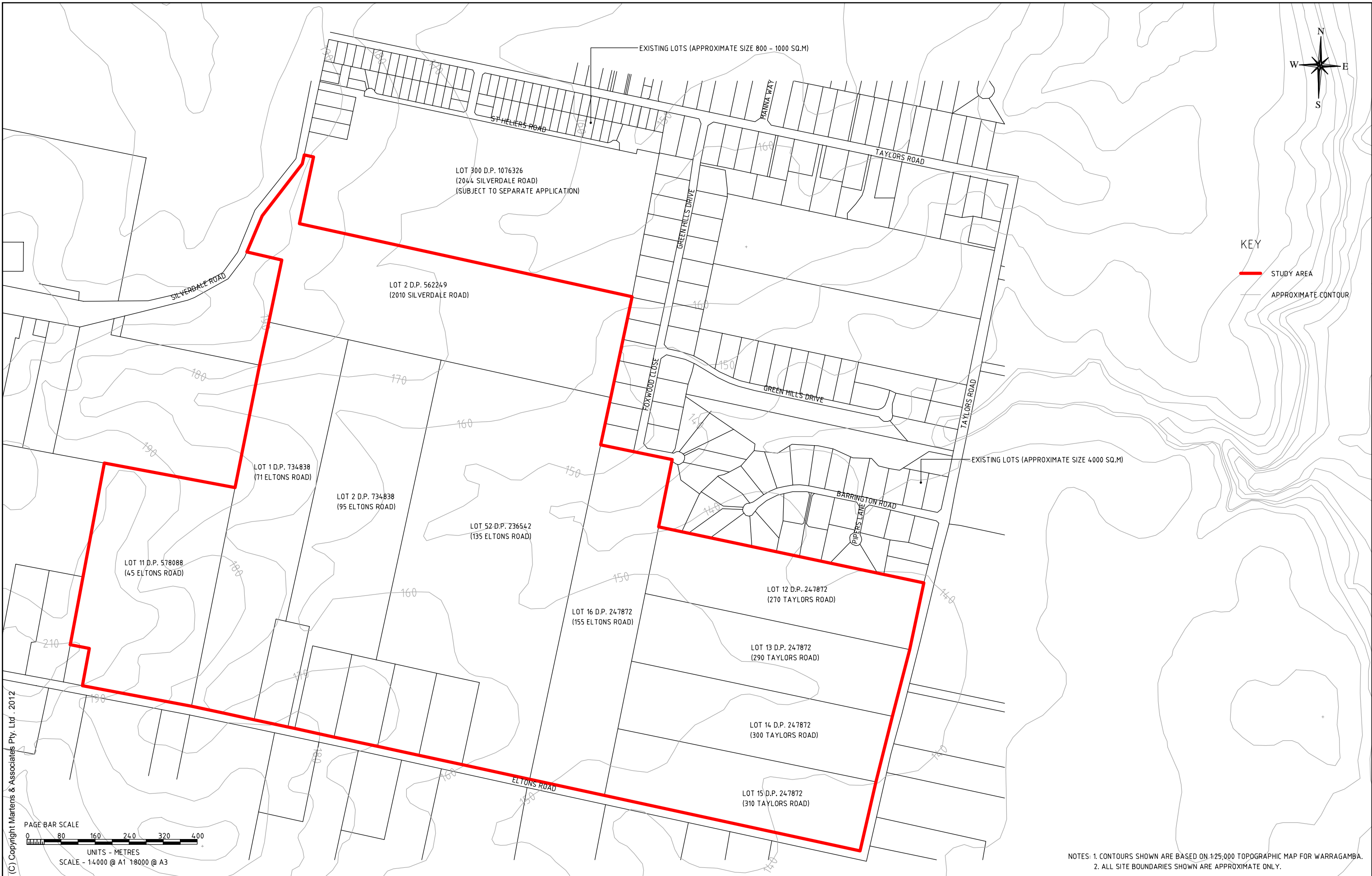

Copyright Martens & Associates Pty. Ltd. 2012

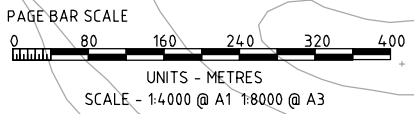

martens ASSOCIATES PTY LTD
 Sustainable Solutions
 Environmental - Geotechnical - Civil
 Hydraulic - Wastewater Engineers

6/37 Leighton Place
 Hornsby, NSW 2077 Australia
 Phone: (02) 9476 9999
 Fax: (02) 9476 8767
 Email: mail@martens.com.au
 Internet: http://www.martens.com.au

CLIENT/PROJECT
 PLANNING INGENUITY
 SILVERDALE REZONING

THIS PLAN MUST NOT BE USED FOR CONSTRUCTION UNLESS
 SIGNED AS APPROVED BY PRINCIPAL CERTIFYING AUTHORITY
 All measurements in mm unless otherwise specified.

TITLE
 PROPOSED REZONING - STUDY AREA

PROJECT MANAGER:
 GRAY TAYLOR

DRAWING NUMBER:
 P1103173J001V02

DESIGNED:
 MGD

DRAWN:
 MGD

REVIEWED:
 GT / DMM

DATUM:
 M RL

HORIZONTAL RATIO:
 1:4000 @ A1
 1:8000 @ A3

VERTICAL RATIO:
 1:4000 @ A1
 1:8000 @ A3

REV.	DESCRIPTION	DATE	ISSUED
1	ATTACHMENT A	12.10.2011	DMM
2	ATTACHMENT A	15.02.2012	DMM

SHEET 1 OF 4 SHEETS
 PAPER SIZE: A1 / A3

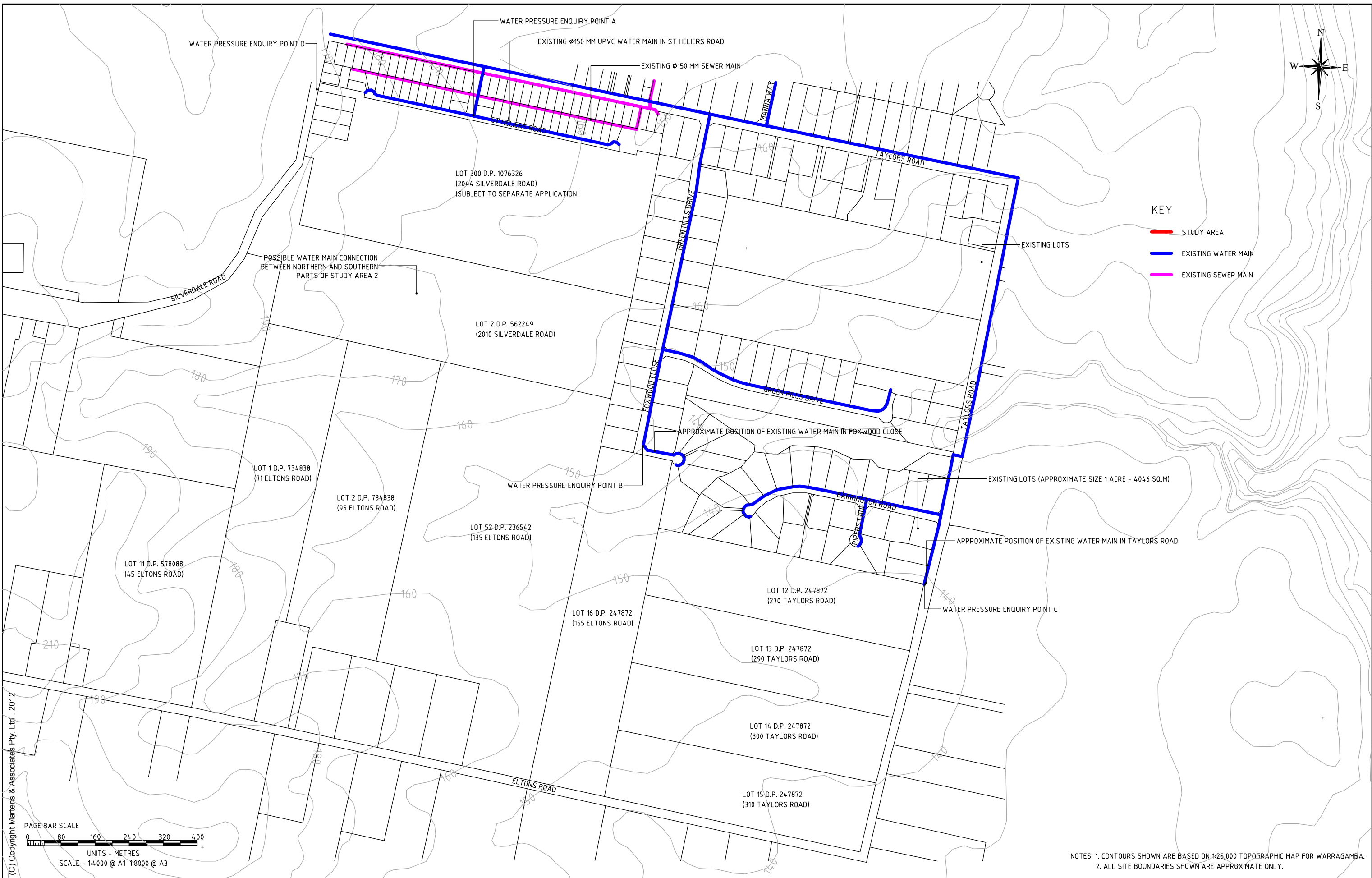

Copyright Martens & Associates Pty. Ltd. 2012

martens **MARTENS & ASSOCIATES PTY LTD**
 Sustainable Solutions
 Environmental - Geotechnical - Civil
 Hydraulic - Wastewater Engineers

6/37 Leighton Place
 Hornsby, NSW 2077 Australia
 Phone: (02) 9476 9999
 Fax: (02) 9476 8767
 Email: mail@martens.com.au
 Internet: http://www.martens.com.au

CLIENT/PROJECT	PLANNING INGENUITY SILVERDALE REZONING
THIS PLAN MUST NOT BE USED FOR CONSTRUCTION UNLESS SIGNED AS APPROVED BY PRINCIPAL CERTIFYING AUTHORITY All measurements in mm unless otherwise specified.	

TITLE	PROPOSED REZONING - EXISTING SERVICES
PROJECT MANAGER:	GRAY TAYLOR

DESIGNED:	MGD	DATUM:	M RL
DRAWN:	MGD	HORIZONTAL RATIO:	1:4000 @ A1 1:8000 @ A3
REVIEWED:	GT / DMM	VERTICAL RATIO:	1:4000 @ A1 1:8000 @ A3
DRAWING NUMBER:		P1103173J001V02	

SHEET	2	DATE	12.10.2011
OF 4 SHEETS		ISSUED	DMM
PAPER SIZE:	A1 / A3		

REV.	DESCRIPTION	DATE	ISSUED
1	ATTACHMENT A	12.10.2011	DMM
2	ATTACHMENT A	15.02.2012	DMM

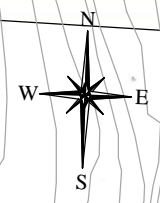

KEY

- WATER SUPPLY AREA A (LOTS BELOW 160 MAHD)
- WATER SUPPLY AREA B (LOTS 160-180 MAHD)
- WATER SUPPLY AREA C (LOTS ABOVE 180 MAHD)
- WATER SUPPLY AREA LOT 300 (1000 SQ.M LOTS)
- APPROXIMATE CONTOUR

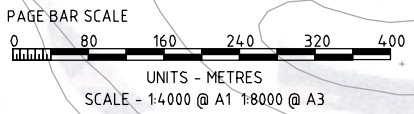
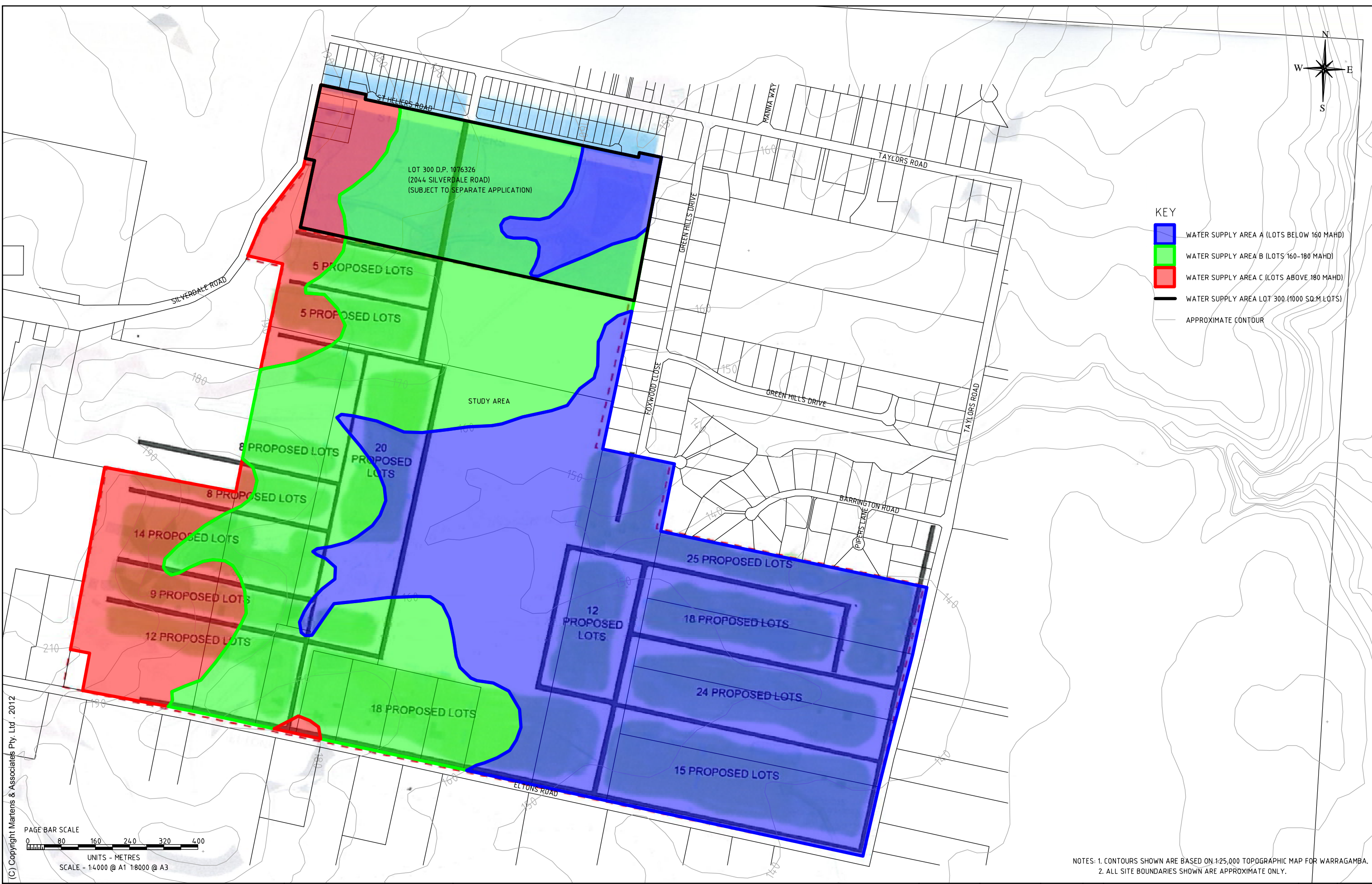

NOTES: 1. CONTOURS SHOWN ARE BASED ON 1:25,000 TOPOGRAPHIC MAP FOR WARRAGAMBA.
2. ALL SITE BOUNDARIES SHOWN ARE APPROXIMATE ONLY.

Copyright Martens & Associates Pty. Ltd. 2012

martens **MARTENS & ASSOCIATES PTY LTD**
 Sustainable Solutions
 Environmental - Geotechnical - Civil
 Hydraulic - Wastewater Engineers

6/37 Leighton Place
 Hornsby, NSW 2077 Australia
 Phone: (02) 9476 9999
 Fax: (02) 9476 8767
 Email: mail@martens.com.au
 Internet: http://www.martens.com.au

CLIENT/PROJECT
 PLANNING INGENUITY
 SILVERDALE REZONING

THIS PLAN MUST NOT BE USED FOR CONSTRUCTION UNLESS
 SIGNED AS APPROVED BY PRINCIPAL CERTIFYING AUTHORITY
 All measurements in mm unless otherwise specified.

TITLE
 PROPOSED REZONING - WATER SUPPLY ZONES

PROJECT MANAGER:
 GRAY TAYLOR

DRAWING NUMBER:
 P1103173.D001V02

DESIGNED:
 MGD

DRAWN:
 MGD

REVIEWED:
 GT / DMM

DATUM:
 M RL

HORIZONTAL RATIO:
 1:4000 @ A1
 1:8000 @ A3

VERTICAL RATIO:
 1:4000 @ A1
 1:8000 @ A3

REV.	DESCRIPTION	DATE	ISSUED
1	ATTACHMENT A	12.10.2011	DMM
2	ATTACHMENT A	15.02.2012	DMM

SHEET 3 OF 4 SHEETS
 PAPER SIZE: A1 / A3

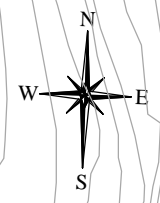

KEY

- INDICATIVE WATER MAIN
- STUDY AREA 1 (1000 SQ.M LOTS)
- WATER SUPPLY AREA 2_a (LOTS ABOVE 180 MAHD)
- WATER SUPPLY AREA 2_b (LOTS 160-180 MAHD)
- WATER SUPPLY AREA 2_c (LOTS BELOW 160 MAHD)
- APPROXIMATE CONTOUR

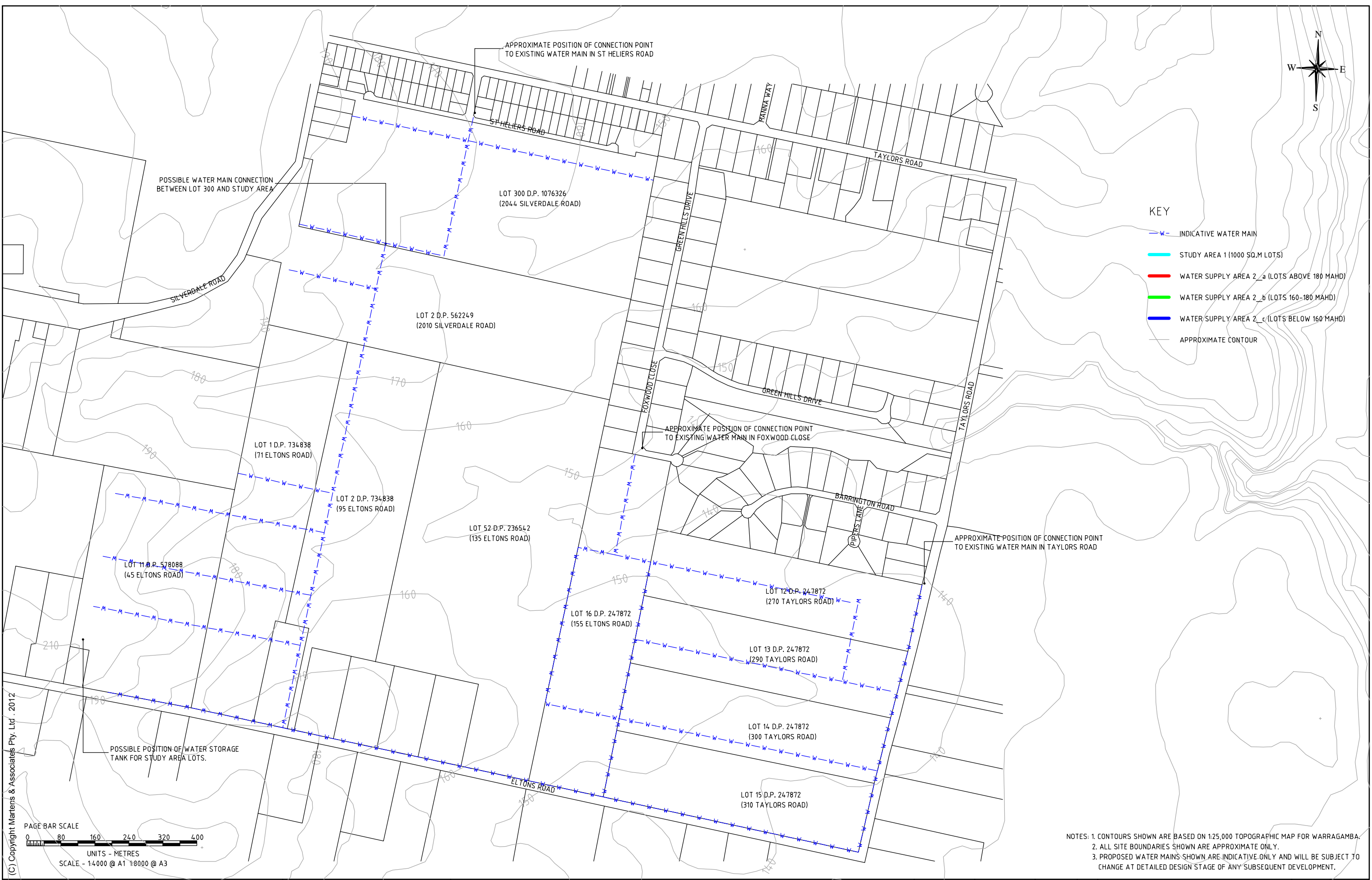

NOTES: 1. CONTOURS SHOWN ARE BASED ON 1:25,000 TOPOGRAPHIC MAP FOR WARRAGAMBA.
 2. ALL SITE BOUNDARIES SHOWN ARE APPROXIMATE ONLY.
 3. PROPOSED WATER MAINS SHOWN ARE INDICATIVE ONLY AND WILL BE SUBJECT TO CHANGE AT DETAILED DESIGN STAGE OF ANY SUBSEQUENT DEVELOPMENT.

Copyright Martens & Associates Pty. Ltd. 2012

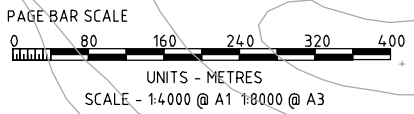

martens **MARTENS & ASSOCIATES PTY LTD**
 Sustainable Solutions
 Environmental - Geotechnical - Civil
 Hydraulic - Wastewater Engineers

6/37 Leighton Place
 Hornsby, NSW 2077 Australia
 Phone: (02) 9476 9999
 Fax: (02) 9476 8767
 Email: mail@martens.com.au
 Internet: http://www.martens.com.au

CLIENT/PROJECT
 PLANNING INGENUITY
 SILVERDALE REZONING

THIS PLAN MUST NOT BE USED FOR CONSTRUCTION UNLESS SIGNED AS APPROVED BY PRINCIPAL CERTIFYING AUTHORITY. All measurements in mm unless otherwise specified.

TITLE
 PROPOSED REZONING - POSSIBLE CONFIGURATION OF NEW WATER SERVICES

PROJECT MANAGER:
 GRAY TAYLOR

DRAWING NUMBER:
 P1103173J001V02

DESIGNED:
 MGD

DATUM:
 M RL

DRAWN:
 MGD

HORIZONTAL RATIO:
 1:4000 @ A1
 1:8000 @ A3

REVIEWED:
 GT / DMM

VERTICAL RATIO:
 1:4000 @ A1
 1:8000 @ A3

REV.	DESCRIPTION	DATE	ISSUED
1	ATTACHMENT A	12.10.2011	DMM
2	ATTACHMENT A	15.02.2012	DMM

SHEET 4 OF 4 SHEETS
 PAPER SIZE: A1 / A3

**6 Attachment B – Sydney Water Pressure and Flow
Information**

BY:

Statement of Available Pressure and Flow

Martens & Associates
6/37 Leighton Pl
Hornsby, 2077

WMS No: **158508**
Contact No: 8849-3531
Fax No: 8849-3113

Attention: Nathan Foster

Date: 26/09/2011

Pressure & Flow Application Number: 3274542
Your Pressure Inquiry Dated: Wed September 21 2011
Property Address: 2044 Silverdale Rd Silverdale 2752

The expected maximum and minimum pressures available in the water main given below relate to modelled existing demand conditions, either with or without extra flows for emergency fire fighting, and are not to be construed as availability for normal domestic supply for any proposed development.

ASSUMED CONNECTION DETAILS

Street Name: Silverdale Rd	Side of Street: East
Distance & Direction from Nearest Cross Street	170 metres South from Taylors Rd
Approximate Ground Level (AHD):	195 metres
Nominal Size of Water Main (DN):	100 mm

EXPECTED WATER MAIN PRESSURES AT CONNECTION POINT

Normal Supply Conditions	
Maximum Pressure	26 metre head
Minimum Pressure	20 metre head

WITH PROPERTY FIRE PREVENTION SYSTEM DEMANDS	Flow l/s	Pressure head m
Fire Hose Reel Installations (Two hose reels simultaneously)	0.66	20
Fire Hydrant / Sprinkler Installations (Pressure expected to be maintained for 95% of the time)	5	20
	10	16
	15	11
Fire Installations based on peak demand (Pressure expected to be maintained with flows combined with peak demand in the water main)	5	19
	10	16
	15	10
Maximum Permissible Flow	20	4

(Please refer to reverse side for Notes)

for 
Robert Wickham
Team Leader
Asset Planning

Statement of Available Pressure and Flow

Martens & Associates
6/37 Leighton Pl
Hornsby, 2077

RECEIVED
 27 SEP 2011

WMS No: **158528**
 Contact No: 8849-3531
 Fax No: 8849-3113

Attention: Michael

BY:

Date: 26/09/2011

Pressure & Flow Application Number: 3274561
Your Pressure Inquiry Dated: Wed September 21 2011
Property Address: 270 Taylors Rd Silverdale 2752

The expected maximum and minimum pressures available in the water main given below relate to modelled existing demand conditions, either with or without extra flows for emergency fire fighting, and are not to be construed as availability for normal domestic supply for any proposed development.

ASSUMED CONNECTION DETAILS

Street Name: Taylors Rd	Side of Street: West
Distance & Direction from Nearest Cross Street	600 metres North from Eltons Rd
Approximate Ground Level (AHD):	136 metres
Nominal Size of Water Main (DN):	100 mm

EXPECTED WATER MAIN PRESSURES AT CONNECTION POINT

Normal Supply Conditions	
Maximum Pressure	85 metre head
Minimum Pressure	66 metre head

WITH PROPERTY FIRE PREVENTION SYSTEM DEMANDS	Flow l/s	Pressure head m
Fire Hose Reel Installations (Two hose reels simultaneously)	0.66	62
Fire Hydrant / Sprinkler Installations (Pressure expected to be maintained for 95% of the time)	5	46
Fire Installations based on peak demand (Pressure expected to be maintained with flows combined with peak demand in the water main)	5	37
Maximum Permissible Flow	7	17

(Please refer to reverse side for Notes)

for 
Robert Wickham
Team Leader
Asset Planning

Statement of Available Pressure and Flow

Martens & Associates
6/37 Leighton PI
Hornsby, 2077

RECEIVED
 27 SEP 2011

WMS No: **158529**
 Contact No: 8849-3531
 Fax No: 8849-3113

Attention: Michael

BY:

Date: 26/09/2011

Pressure & Flow Application Number: 3274562
Your Pressure Inquiry Dated: Wed September 21 2011
Property Address: 270 Taylors Rd Silverdale 2752

The expected maximum and minimum pressures available in the water main given below relate to modelled existing demand conditions, either with or without extra flows for emergency fire fighting, and are not to be construed as availability for normal domestic supply for any proposed development.

ASSUMED CONNECTION DETAILS

Street Name: St Heliers Rd	Side of Street: North
Distance & Direction from Nearest Cross Street	120 metres South from Taylors Rd
Approximate Ground Level (AHD):	170 metres
Nominal Size of Water Main (DN):	100 mm

EXPECTED WATER MAIN PRESSURES AT CONNECTION POINT

Normal Supply Conditions	
Maximum Pressure	51 metre head
Minimum Pressure	42 metre head

WITH PROPERTY FIRE PREVENTION SYSTEM DEMANDS	Flow l/s	Pressure head m
Fire Hose Reel Installations (Two hose reels simultaneously)	0.66	41
Fire Hydrant / Sprinkler Installations (Pressure expected to be maintained for 95% of the time)	5	41
	10	37
	15	30
Fire Installations based on peak demand (Pressure expected to be maintained with flows combined with peak demand in the water main)	5	38
	10	33
	15	25
Maximum Permissible Flow	19	17

(Please refer to reverse side for Notes)

for 
Robert Wickham
Team Leader
Asset Planning

Statement of Available Pressure and Flow

Martens & Associates
6/37 Leighton Pl
Hornsby, 2077

RECEIVED
 27 SEP 2011

WMS No: **158510**
 Contact No: **8849-3531**
 Fax No: **8849-3113**

Attention: Michael

BY:

Date: 26/09/2011

Pressure & Flow Application Number: 3274551
Your Pressure Inquiry Dated: Wed September 21 2011
Property Address: 136 Eltons Rd Silverdale 2752

The expected maximum and minimum pressures available in the water main given below relate to modelled existing demand conditions, either with or without extra flows for emergency fire fighting, and are not to be construed as availability for normal domestic supply for any proposed development.

ASSUMED CONNECTION DETAILS

Street Name: Foxwood Cl	Side of Street: North
Distance & Direction from Nearest Cross Street	820 metres South from Taylors Rd
Approximate Ground Level (AHD):	146 metres
Nominal Size of Water Main (DN):	100 mm

EXPECTED WATER MAIN PRESSURES AT CONNECTION POINT

Normal Supply Conditions	
Maximum Pressure	75 metre head
Minimum Pressure	63 metre head

WITH PROPERTY FIRE PREVENTION SYSTEM DEMANDS	Flow l/s	Pressure head m
Fire Hose Reel Installations (Two hose reels simultaneously)	0.66	62
Fire Hydrant / Sprinkler Installations (Pressure expected to be maintained for 95% of the time)	5 10	56 36
Fire Installations based on peak demand (Pressure expected to be maintained with flows combined with peak demand in the water main)	5 10	51 29
Maximum Permissible Flow	14	4

(Please refer to reverse side for Notes)

for
Robert Wickham
Team Leader
Asset Planning

7 Attachment C – Pipes Model

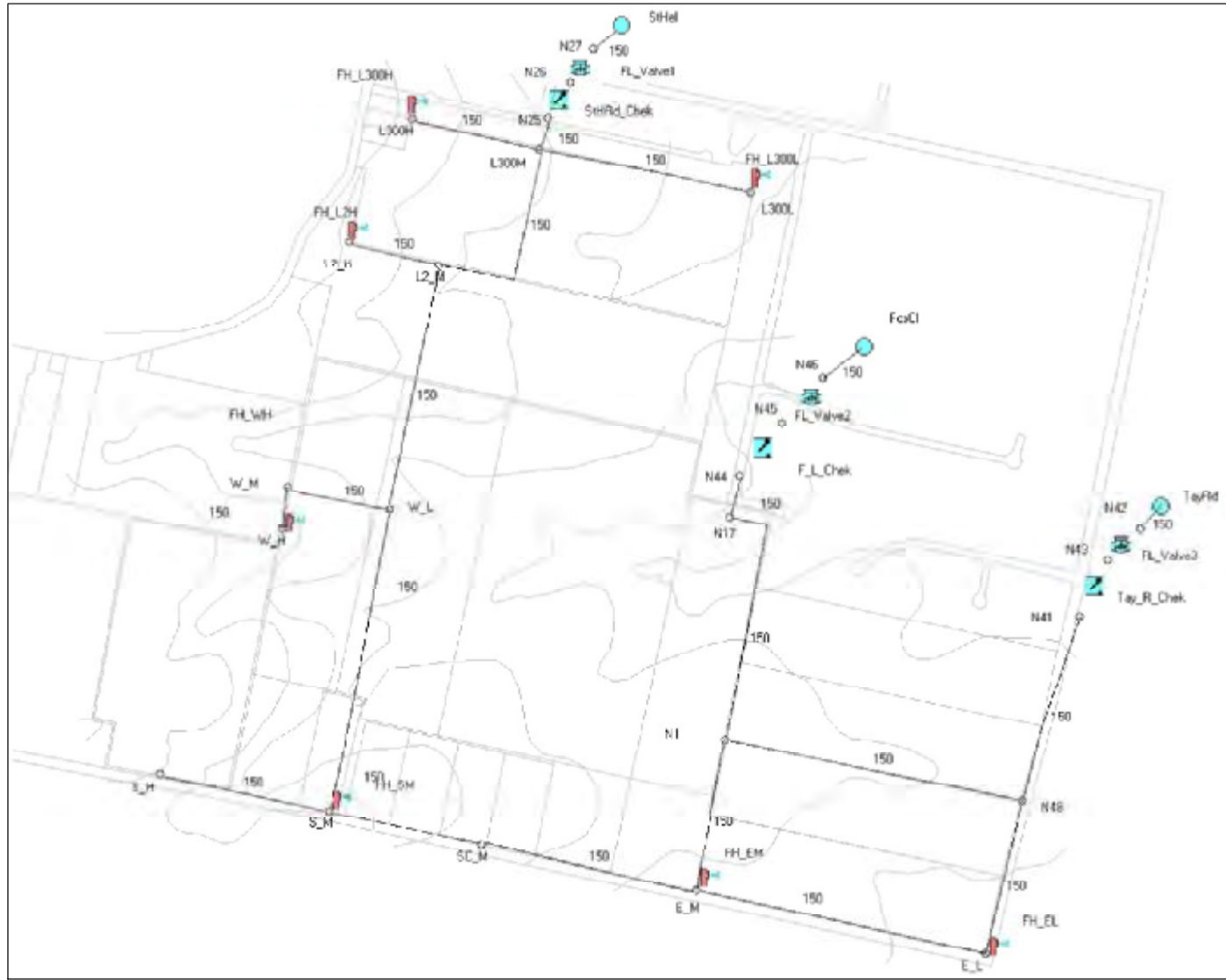

SET-UP

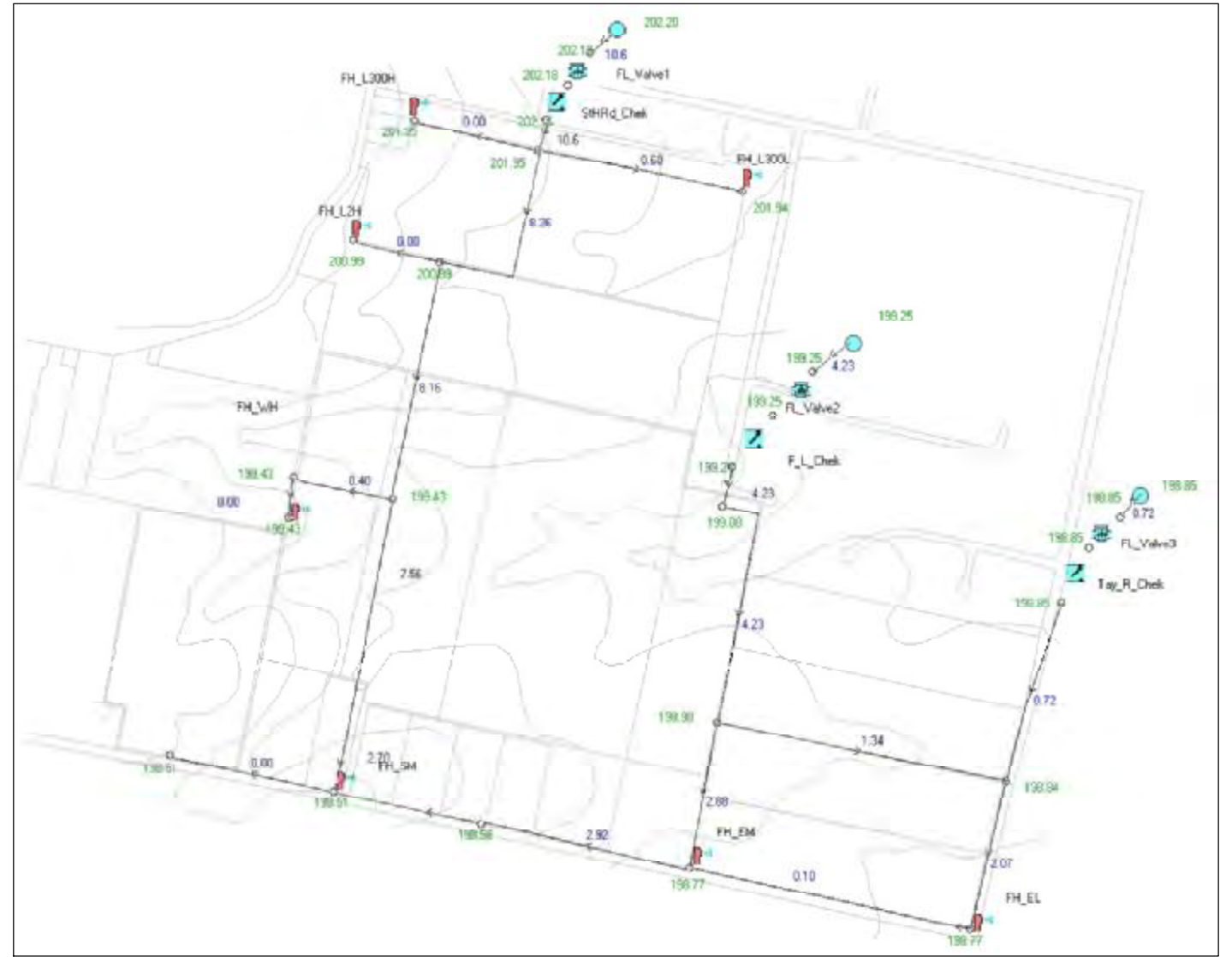

RESULTS

NOTE: RESULTS SHOWN FOR SCENARIO 2, AVERAGE DAILY WATER DEMAND WITH FIRE SUPPLY

(C) Copyright Martens & Associates Pty. Ltd . 2012

martens **MARTENS & ASSOCIATES PTY LTD**
 Sustainable Solutions
 Environmental - Geotechnical - Civil
 Hydraulic - Wastewater Engineers

6/37 Leighton Place
 Hornsby, NSW 2077 Australia
 Phone: (02) 9476 9999
 Fax: (02) 9476 8767
 Email: mail@martens.com.au
 Internet: http://www.martens.com.au

CLIENT/PROJECT PLANNING INGENUITY SILVERDALE REZONING	TITLE PROPOSED REZONING - HYDRAULIC MODEL (PIPES) SET-UP AND RESULTS
THIS PLAN MUST NOT BE USED FOR CONSTRUCTION UNLESS SIGNED AS APPROVED BY PRINCIPAL CERTIFYING AUTHORITY All measurements in mm unless otherwise specified.	PROJECT MANAGER: GRAY TAYLOR

DESIGNED: MGD	DATUM: M RL	SHEET 1	REV. 1	DESCRIPTION ATTACHMENT C	DATE 12.10.2011	ISSUED DMM
DRAWN: MGD	HORIZONTAL RATIO: 1:4000 @ A1 1:8000 @ A3	OF 1 SHEETS	REV. 2	DESCRIPTION ATTACHMENT C	DATE 15.02.2012	ISSUED DMM
REVIEWED: GT / DMM	VERTICAL RATIO: 1:4000 @ A1 1:8000 @ A3	PAPER SIZE: A1 / A3				

DRAWING NUMBER: P1103173.J001V02	
-------------------------------------	--



ANNEXURE D

TRAFFIC IMPACT REVIEW

MCLAREN TRAFFIC ENGINEERING



**ELTONS ROAD, SILVERDALE
FEBRUARY 2012**



**TRAFFIC IMPACT REVIEW FOR
PROPOSED RESIDENTIAL DEVELOPMENT
ELTONS RD, SILVERDALE**

**M^CLAREN TRAFFIC ENGINEERING
LEVEL 1, 29 KIORA ROAD
MIRANDA NSW 2228
PH (02) 8543 3811 FAX (02) 8543 3849
Email : mclarenc@ozemail.com.au**



TABLE OF CONTENTS

1. INTRODUCTION	1
2. SEPP 11 REQUIREMENTS	1
3. EXISTING ROAD & TRAFFIC CONDITIONS	1
3.1 ROAD HIERARCHY	1
3.2 EXISTING TRAFFIC MANAGEMENT	1
3.3 EXISTING TRAFFIC VOLUMES	1
3.4 TRAFFIC FLOWS	1
3.5 PUBLIC TRANSPORT SERVICES	2
4. TRAFFIC GENERATION	2
4.1 TRAFFIC GENERATION & ASSIGNMENT	2
4.2 IMPACT ON TRAFFIC FLOW EFFICIENCY, ROAD SAFETY & RESIDENTIAL AMENITY	2
5. CONCLUSIONS	4



1. INTRODUCTION

M^CLaren Traffic Engineering was commissioned by Wollondilly Shire Council to undertake an assessment of the traffic impacts of a proposed residential development along Eltons Rd, Silverdale.

The site is known as Eltons Rd, Silverdale and is located on the northern side of Eltons Rd, south of St Heliers Rd and west of Silverdale Rd. The proposed site has an area of 166.8 hectares. The location of the site is shown in **Figure 1**.

2. SEPP 11 REQUIREMENTS

The proposed masterplan residential development scale considered in this report is in the order of 193 RURAL dwellings. This subdivision development scale DOES NOT qualify as a Schedule 3 development for the purpose of application of State Environmental Planning Policy (Infrastructure) 2007 and accordingly DOES NOT require formal referral to the RTA (RMS) and can be dealt with by Council's planners and / or local traffic committee.

3. EXISTING ROAD & TRAFFIC CONDITIONS

3.1 Road Hierarchy

Silverdale Rd, Mulgoa Road and Park Road are regional roads under the care and control of both the Roads and Traffic Authority and Wollondilly Shire Council. Eltons Road and St Heliers Road are local roads under the care and control of Wollondilly Shire Council.

3.2 Existing Traffic Management

Priority control intersection traffic management conditions apply for all junctions within the immediate vicinity and surrounding environs of the site. A single lane roundabout control exists at the intersection of Silverdale Road, Mulgoa Road and Park Road.

3.3 Existing Traffic Volumes

The existing traffic volumes on the roads surrounding the site are described below in terms of either Average Annual Daily Traffic (AADT). The RTA publication, Traffic Volume Data for the Sydney Region, 2002 contains AADT volumes for most major roads in the Sydney metropolitan area, The AADT figure at a given point represents the average number of axle pairs passing in both directions in a 24 hour period, estimated over a period of one year. The AADT for Silverdale Road at the Nepean River Bridge in 2002 was **8201** vehicles.

3.4 Traffic Flows

M^CLaren Traffic Engineering has undertaken existing weekday morning peak hour counts on 18th November 2011, from 6:00am to 9:00am at the intersection of Silverdale Road with Mulgoa Road and Park Road. The evening peak hour counts



were estimated based on the morning peak hour counts and was assumed to occur from 5.00 to 6.00 PM.

The results of the peak hour intersection counts are shown in **Figure 2**. It is important to note that the weekday morning peak period occurs at 7:00am to 8:00am for the intersection shown in **Figure 2**.

3.5 Public Transport Services

Public buses do not currently operate along Eltons Road or St Heliers Road; however a bus service currently operates along Silverdale Road to the east of the proposed development. There is currently **1** bus route that services the segment of Silverdale Road adjacent to the site (shown in **Annexure B**). Route 32 provides access to the south of the development and as far north as Warragamba. Catching the public buses any further north requires changing buses at Warragamba and taking Route 795.

4. TRAFFIC GENERATION

4.1 Traffic Generation & Assignment

In daily terms the proposed development is expected to generate in the order of **1,737** vehicles per day, based upon traffic generation rates contained in Section 3.3.2 of the RTA's *"Guide to Traffic Generating Developments"*, October 2002, as shown in **Table 1** below.

TABLE 1: TRAFFIC GENERATION

Dwelling Structure Type	Scale	Daily		Peak Hour	
		Rate	Volume	Rate	Volume
Single detached Dwellings	193	9	1737	0.85	164

The peak hour vehicle trip generation (i.e. 7-8am and 5-6pm) is **164** vehicle trips, with about 80% in the peak direction of travel (i.e. leaving the residential development in the morning and returning to the residential development in the evening). The peak directional traffic volume therefore equates to **131** vehicle trips or **2.2** vehicles per minute during peak weekday commuter periods. This is a moderately low peak hour traffic generation level.

It has been approximated that 95% of the vehicles leaving the residential development in the morning will travel in a northern direction, whilst 95% of the vehicles returning to the residential development will be travelling in a southern direction.

4.2 Impact on Traffic Flow Efficiency, Road Safety & Residential Amenity

The impact of generated traffic has been assessed in terms of impacts on the performance of a nearby roundabout intersection. The performance of the selected key intersections have been assessed with the aid of the **SIDRA Intersection 5.0** computer programme which is used to evaluate the performance of intersections controlled by stop/give way signs, roundabouts or signals. It provides a number of measures of performance including vehicle delay, degree of saturation, and level of service.



M^CLaren Traffic Engineering has undertaken existing weekday morning peak hour counts on 18th November 2011, from 6:00am to 9:00am at the roundabout intersection of Silverdale Road with Mulgoa Road and Park Road. The results of the peak hour intersection counts are shown in **Figures 2 & 3**.

The intersection performances modelled include the following tested scenarios:

- The existing November 2011 base case condition.
- Plus the traffic generation from the proposed residential development along Eltons Road. (Future AM and PM traffic have been shown in **Figures 4 & 5**)

The results of the existing analysis are presented in **Table 2** below.

TABLE 2: Existing Intersection Performance (“SIDRA Intersection 5.0”)

Intersection	Peak Hour	Degree of Saturation ⁽¹⁾	Average Delay ⁽²⁾ (sec/vehicle)	Level of Service ⁽³⁾	Queue Length	Control Type	Worst Movement
FUTURE PERFORMANCE							
Silverdale Rd/ Mulgoa Rd/ Park Rd	7.00-8.00	0.50	9.4 (11.8)	A (Worst: A)	21.0m	Round-about	Right turn from Mulgoa Rd
Silverdale Rd/ Mulgoa Rd/ Park Rd	17.00-18.00	0.41	9.4(11.9)	A (Worst: A)	20.0m	Round-about	Right turn from Park Rd

NOTES:

(1) Degree of Saturation is the ratio of demand to capacity for the most disadvantaged movement.

(2) Average delay is the delay experienced on average by all vehicles. The value in brackets represents the delay to the most disadvantaged movement.

(3) Level of Service is a qualitative measure of performance describing operational conditions. There are six levels of service, designated from A to F, with A representing the best operational condition and level of service F the worst. The LoS of the intersection is shown in bold, and the LoS of the most disadvantaged movement is shown in brackets.

The results of the future analysis are presented in **Table 3** below.

TABLE 3: FUTURE Intersection Performance (“SIDRA Intersection 5.0”)

Intersection	Peak Hour	Degree of Saturation ⁽¹⁾	Average Delay ⁽²⁾ (sec/vehicle)	Level of Service ⁽³⁾	Queue Length	Control Type	Worst Movement
FUTURE PERFORMANCE							
Silverdale Rd/ Mulgoa Rd/ Park Rd	7.00-8.00	0.59	9.5 (12.3)	A (Worst: A)	28.7m	Round-about	Right turn from Mulgoa Rd
Silverdale Rd/ Mulgoa Rd/ Park Rd	17.00-18.00	0.50	9.8(12.6)	A (Worst: A)	27.3m	Round-about	Right turn from Park Rd

NOTES:

(1) Degree of Saturation is the ratio of demand to capacity for the most disadvantaged movement.

(2) Average delay is the delay experienced on average by all vehicles. The value in brackets represents the delay to the most disadvantaged movement.

(3) Level of Service is a qualitative measure of performance describing operational conditions. There are six levels of service, designated from A to F, with A representing the best operational condition and level of service F the worst. The LoS of the intersection is shown in bold, and the LoS of the most disadvantaged movement is shown in brackets.



The criteria used to evaluate performance are shown in **Annexure A**. It is evident from **Table 3** and **Annexure A** that the key intersection modelled operates at level of service "A" condition, which represents GOOD performance. In terms of road safety impacts, it is considered that the proposed development will not generate any adverse road safety conditions.

Accordingly, the tested residential development density range on the subject site can be adequately accommodated, in terms of traffic flow efficiency, by the prevailing surrounding road network without the need for any upgrading of external road conditions.

In addition, adequate road safety conditions can be created subject to further attention to detail for the internal subdivisional road system with adequate regard to pedestrian path planning, bicycle considerations and bus stop planning.

5. CONCLUSIONS

The proposed residential development of 193 dwellings can be accommodated on the subject site within acceptable transport planning and traffic engineering criteria with particular regard to traffic flow efficiency and road safety.

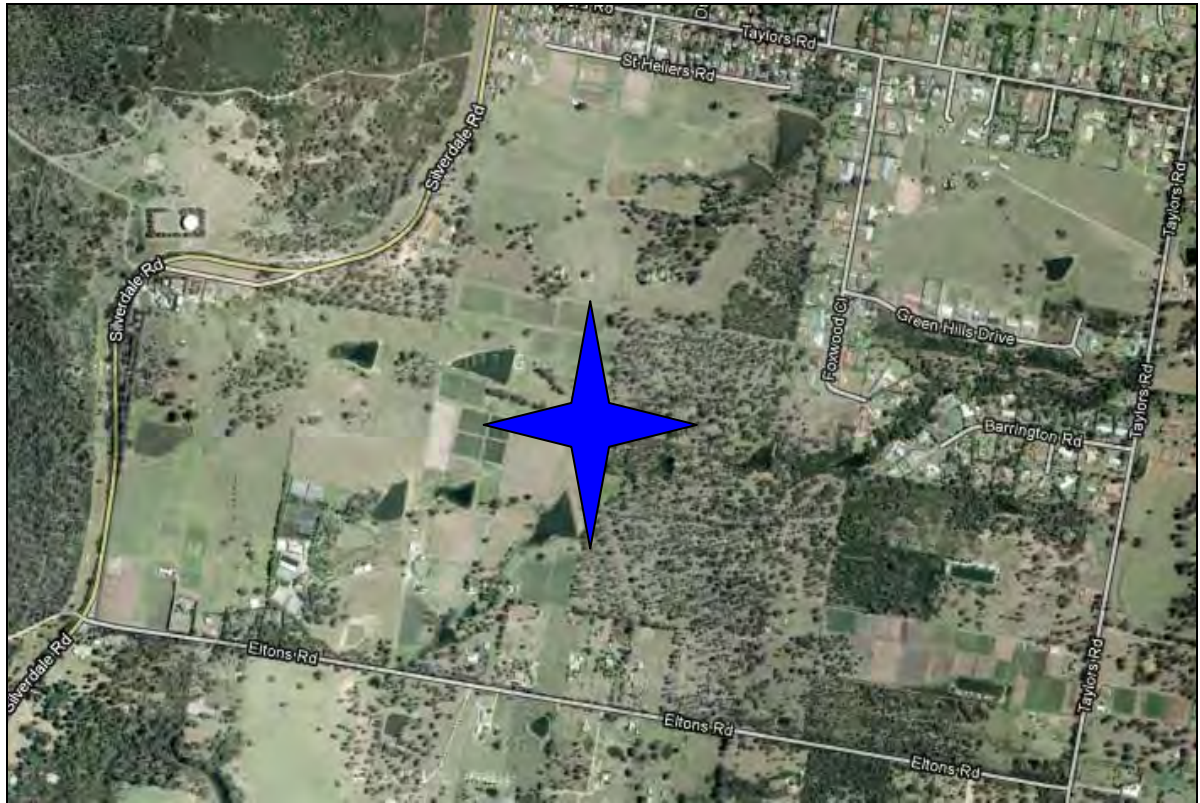

THE SITE

PROPOSED REDSIDENTIAL DEVELOPMENT
ELTONS RD, SILVERDALE



**FIGURE 1:
SITE LOCATION**

PREPARED FOR : WOLLONDILLY SHIRE COUNCIL

BY : M^CLAREN TRAFFIC ENGINEERING



Peak occurs between
7.00 – 8.00 AM

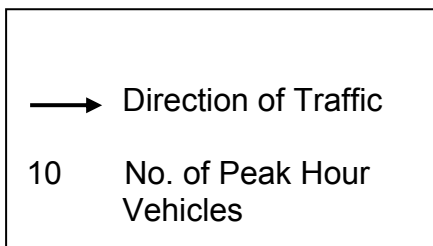
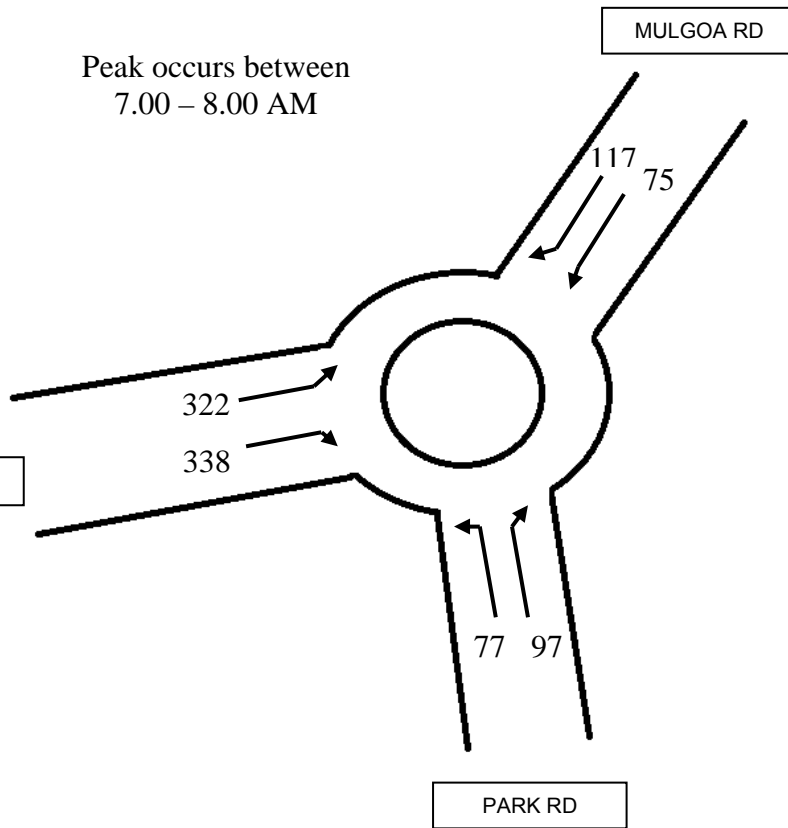
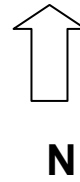

PROPOSED REDSIDENTIAL DEVELOPMENT
ELTONS RD, SILVERDALE

**FIGURE 2:
EXISTING AM PEAK TRAFFIC COUNT
SILVERDALE RD / MULGOA RD**

PREPARED FOR : WOLLONDILLY SHIRE COUNCIL

BY : M^CLAREN TRAFFIC ENGINEERING

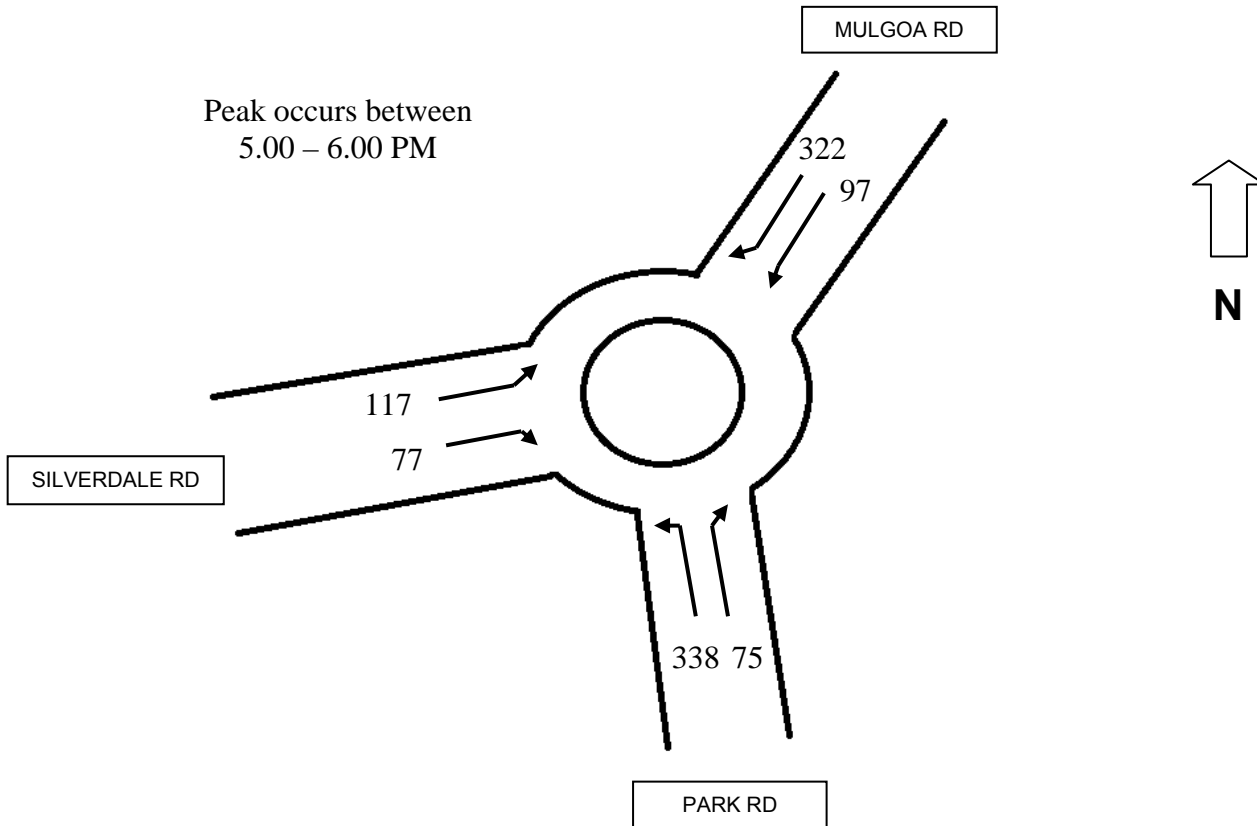

→ Direction of Traffic

10 No. of Peak Hour Vehicles

PROPOSED REDSIDENTIAL DEVELOPMENT
ELTONS RD, SILVERDALE

**FIGURE 3:
EXISTING PM PEAK TRAFFIC COUNT
SILVERDALE RD / MULGOA RD**

PREPARED FOR : WOLLONDILLY SHIRE COUNCIL

BY : M^CLAREN TRAFFIC ENGINEERING



Peak occurs between
7.00 – 8.00 AM

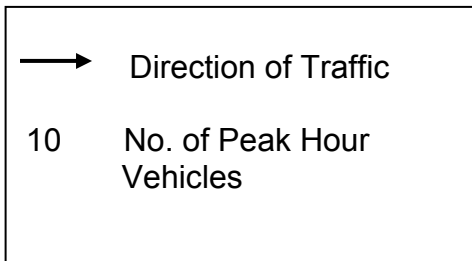
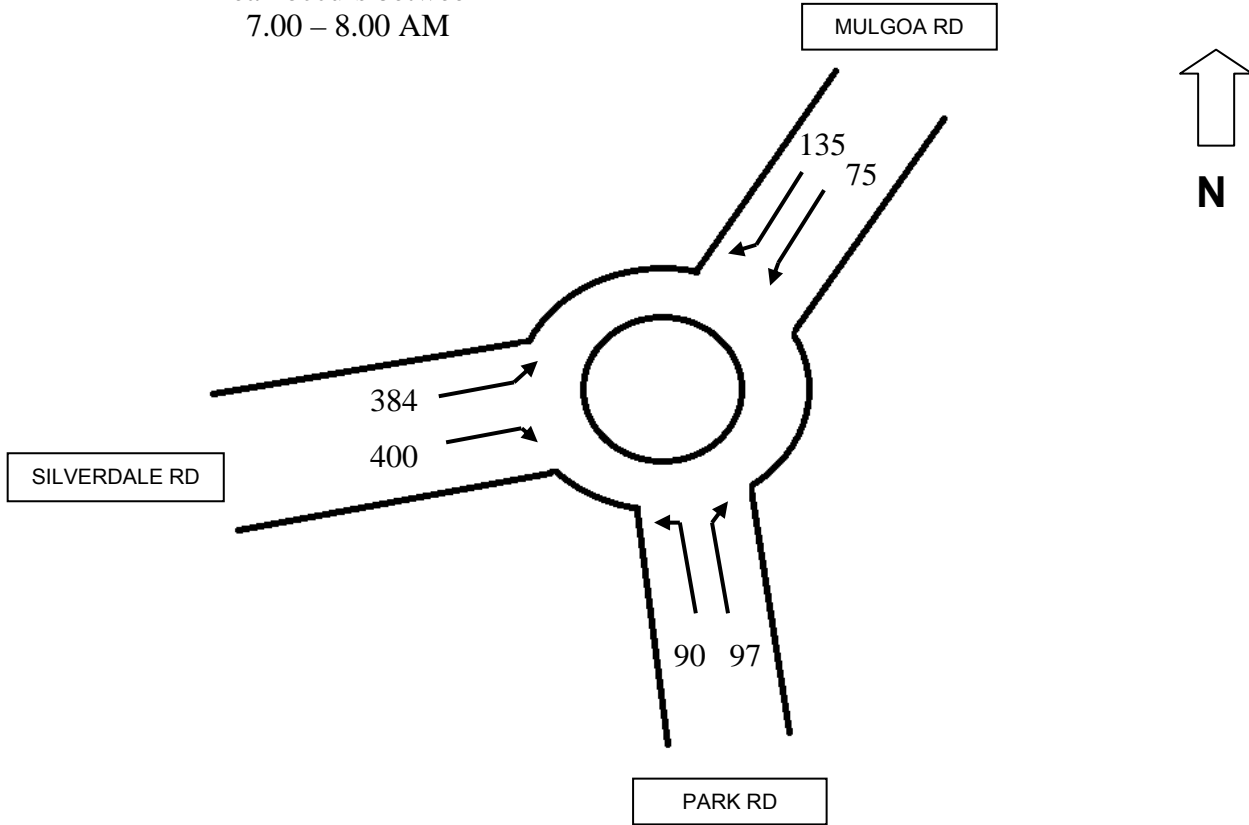

PROPOSED REDSIDENTIAL DEVELOPMENT
ELTONS RD, SILVERDALE

**FIGURE 4:
FUTURE AM PEAK TRAFFIC COUNT
SILVERDALE RD / MULGOA RD**

PREPARED FOR : WOLLONDILLY SHIRE COUNCIL

BY : M^CLAREN TRAFFIC ENGINEERING



Peak occurs between
7.00 – 8.00 AM

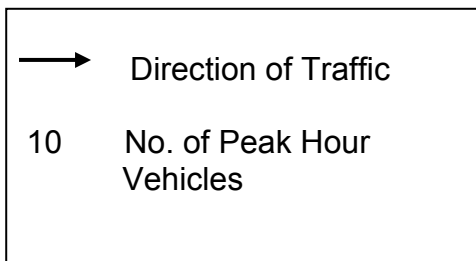
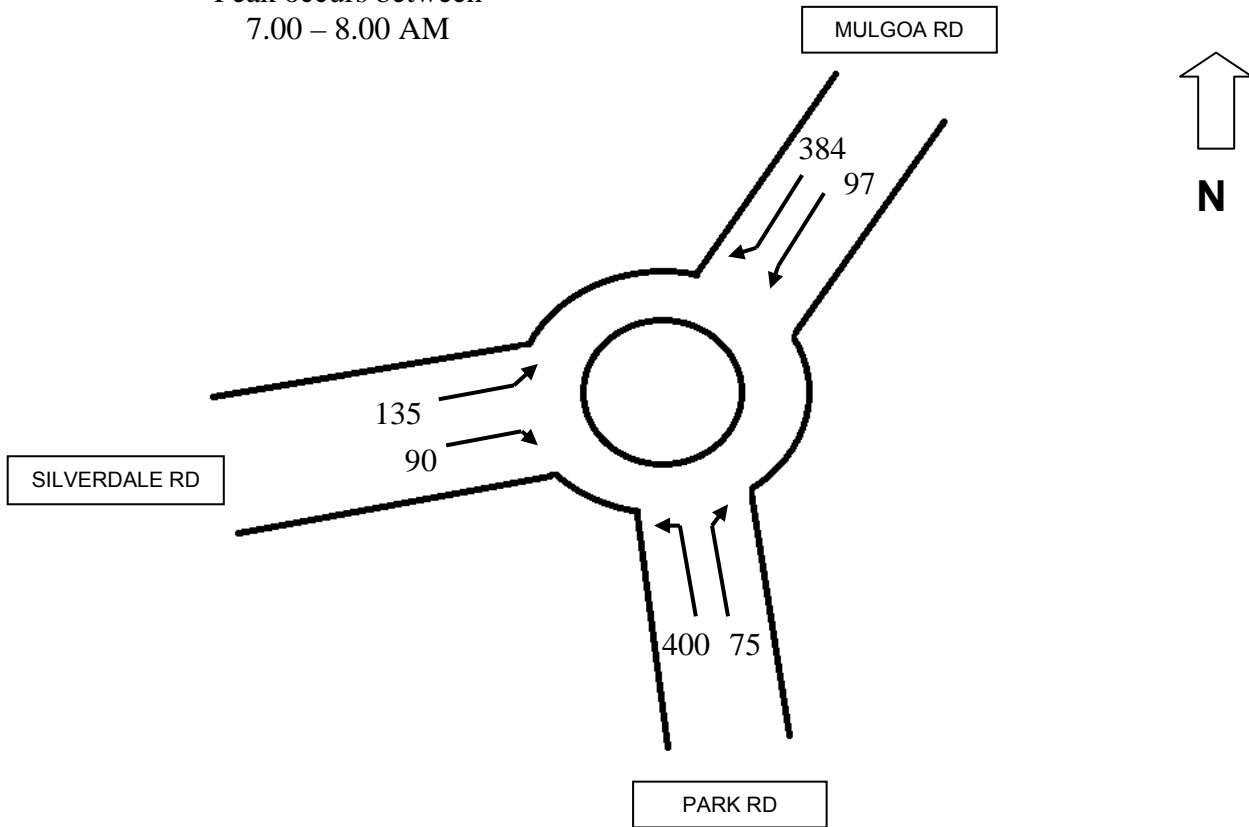

PROPOSED REDSIDENTIAL DEVELOPMENT
ELTONS RD, SILVERDALE



**FIGURE 5:
FUTURE PM PEAK TRAFFIC COUNT
SILVERDALE RD / MULGOA RD**

PREPARED FOR : WOLLONDILLY SHIRE COUNCIL
BY : M^CLAREN TRAFFIC ENGINEERING



ANNEXURE A

Level of Service Criteria

Level of Service	Ave Delay per Vehicle (sec/veh)	Traffic Signals & Roundabouts	Give Way & Stop Signs
A	< 14	Good Operation	Good Operation
B	15 to 28	Good with acceptable delays and spare capacity	Acceptable delays and spare capacity
C	29 to 42	Satisfactory	Satisfactory, but accident study required
D	43 to 56	Operating near capacity	Near capacity and accident study required
E	57 to 70	At capacity; at signals, incidents will cause excessive delays Roundabouts require other control mode	At capacity, requires other control mode
F	over 70	Extra capacity required	Extreme delay, traffic signals or other major treatment required

Adapted from RTA Guide to Traffic Generating Developments, December 2002



ANNEXURE B

Maps of Current Bus Routes



THE SITE

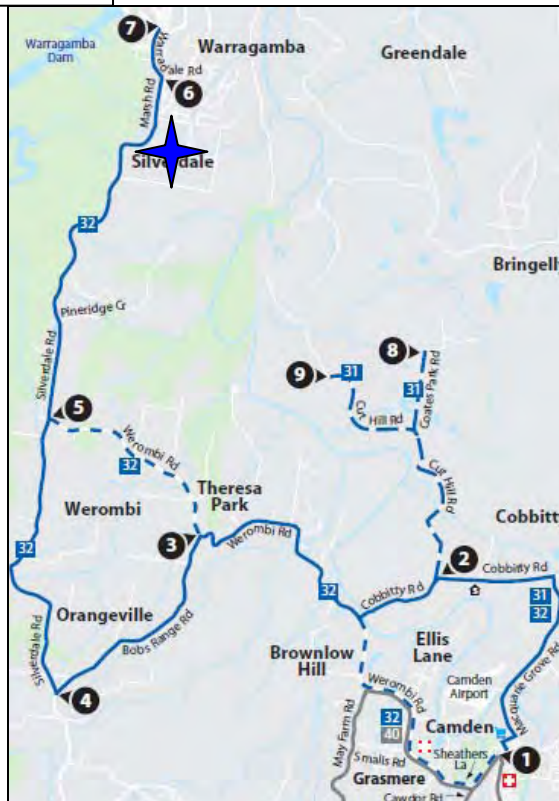



ANNEXURE C – EXISTING TRAFFIC

LAYOUT

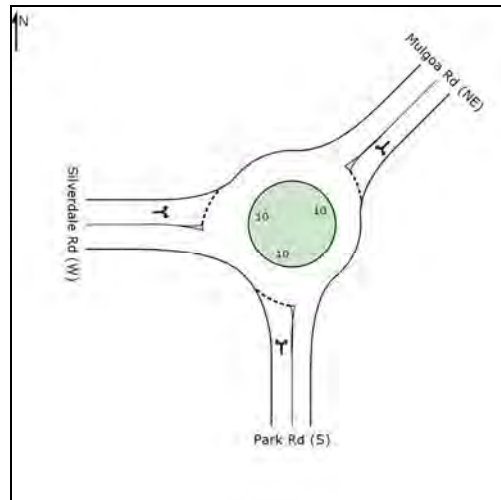

AM VOLUMES

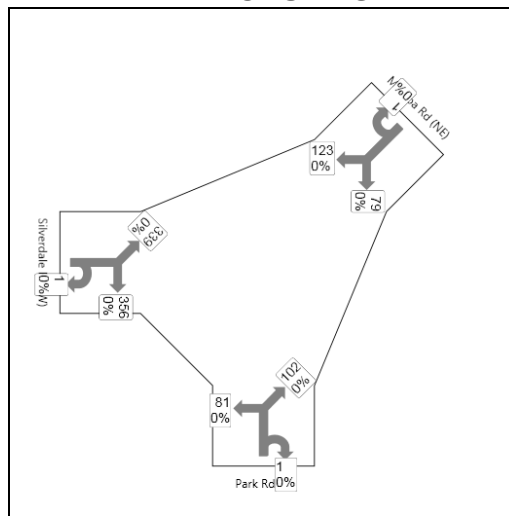

PM VOLUMES

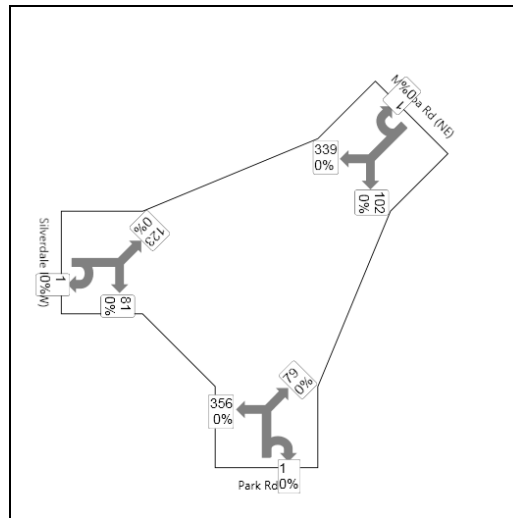

AM OUTPUT

MOVEMENT SUMMARY

Site: SIPAMU - AM

Silverdale Rd / Park Rd / Mulgoa Rd Roundabout

Movement Performance - Vehicles											
Mov ID	Turn	Demand Flow veh/h	HV %	Des Satn veh	Average Delay sec	Level of Service	35% Back of Queue Vehicles veh	Distance m	Prop. Queued	Effective Stop Rate per veh	Average Speed km/h
South: Park Rd (S)											
1	L	81	0.0	0.151	7.9	LOS A	0.9	6.0	0.26	0.59	48.4
3	R	103	0.0	0.151	10.5	LOS A	0.9	6.0	0.26	0.69	46.3
Approach		184	0.0	0.151	9.4	LOS A	0.9	6.0	0.26	0.65	47.2
North East: Mulgoa Rd (NE)											
24	L	79	0.0	0.202	8.3	LOS A	1.3	9.0	0.49	0.63	47.6
26	R	124	0.0	0.202	11.8	LOS A	1.3	9.0	0.49	0.77	45.7
Approach		203	0.0	0.202	10.5	LOS A	1.3	9.0	0.49	0.71	46.4
West: Silverdale Rd (W)											
10	L	339	0.0	0.499	6.8	LOS A	3.0	21.0	0.24	0.53	49.3
12	R	357	0.0	0.500	11.2	LOS A	3.0	21.0	0.24	0.75	45.9
Approach		696	0.0	0.499	9.1	LOS A	3.0	21.0	0.24	0.64	47.5
All Vehicles		1083	0.0	0.499	9.4	LOS A	3.0	21.0	0.29	0.66	47.2

Level of Service (Aver. Int. Delay): LOS A. Based on average delay for all vehicle movements. LOS Method: Delay (RTA NSW).
 Level of Service (Worst Movement): LOS A. LOS Method for individual vehicle movements: Delay (RTA NSW).
 Approach LOS values are based on the worst delay for any vehicle movement.
 Roundabout Capacity Model: SIDRA Standard.

PM OUTPUT

MOVEMENT SUMMARY

Site: SIPAMU - PM

Silverdale Rd / Park Rd / Mulgoa Rd Roundabout

Movement Performance - Vehicles											
Mov ID	Turn	Demand Flow veh/h	HV %	Des Satn veh	Average Delay sec	Level of Service	35% Back of Queue Vehicles veh	Distance m	Prop. Queued	Effective Stop Rate per veh	Average Speed km/h
South: Park Rd (S)											
1	L	356	0.0	0.413	9.2	LOS A	2.9	20.0	0.52	0.71	47.2
3	R	80	0.0	0.412	11.9	LOS A	2.9	20.0	0.52	0.78	45.6
Approach		436	0.0	0.413	9.7	LOS A	2.9	20.0	0.52	0.73	46.9
North East: Mulgoa Rd (NE)											
24	L	102	0.0	0.326	6.9	LOS A	2.3	16.0	0.25	0.50	49.1
26	R	340	0.0	0.327	10.4	LOS A	2.3	16.0	0.25	0.69	46.4
Approach		442	0.0	0.327	9.6	LOS A	2.3	16.0	0.25	0.64	47.0
West: Silverdale Rd (W)											
10	L	123	0.0	0.155	6.7	LOS A	0.7	4.8	0.16	0.52	49.9
12	R	82	0.0	0.155	11.1	LOS A	0.7	4.8	0.16	0.78	46.1
Approach		205	0.0	0.155	8.4	LOS A	0.7	4.8	0.16	0.62	48.3
All Vehicles		1083	0.0	0.413	9.4	LOS A	2.9	20.0	0.34	0.67	47.2

Level of Service (Aver. Int. Delay): LOS A. Based on average delay for all vehicle movements. LOS Method: Delay (RTA NSW).
 Level of Service (Worst Movement): LOS A. LOS Method for individual vehicle movements: Delay (RTA NSW).
 Approach LOS values are based on the worst delay for any vehicle movement.
 Roundabout Capacity Model: SIDRA Standard.



ANNEXURE D – FUTURE TRAFFIC

LAYOUT

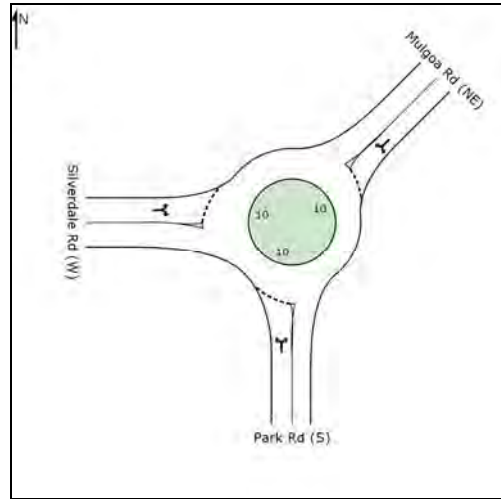

AM VOLUMES

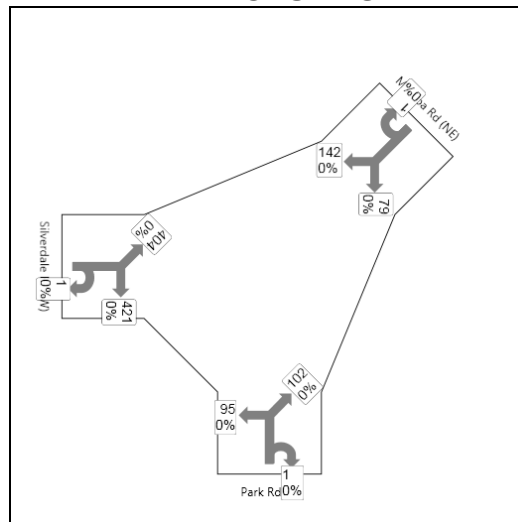

PM VOLUMES

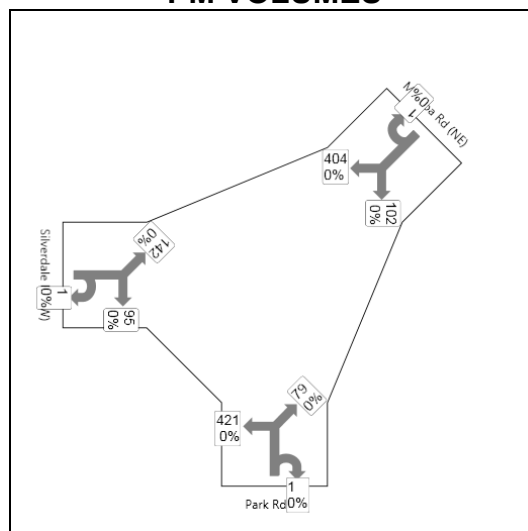



AM OUTPUT

MOVEMENT SUMMARY Site: SIPAMU - AM Future

Silverdale Rd / Park Rd / Mulgoa Rd Roundabout

Movement Performance - Vehicles											
Mov ID	Turn	Demand Flow veh/h	HV %	Des. Satn veh	Average Delay sec	Level of Service	95% Back of Queue Vehicles veh	Distance m	Prop. Queued	Effective Stop Rate per veh	Average Speed km/h
South: Park Rd (S)											
1	L	95	0.0	0.166	8.0	LOS A	1.0	6.8	0.29	0.60	48.2
3	R	103	0.0	0.166	10.6	LOS A	1.0	6.8	0.29	0.68	46.2
Approach		198	0.0	0.166	9.4	LOS A	1.0	6.8	0.29	0.65	47.1
North East: Mulgoa Rd (NE)											
24	L	79	0.0	0.233	8.7	LOS A	1.5	10.8	0.54	0.67	47.2
26	R	143	0.0	0.233	12.3	LOS A	1.5	10.8	0.54	0.79	45.3
Approach		222	0.0	0.233	11.0	LOS A	1.5	10.8	0.54	0.74	46.0
West: Silverdale Rd (W)											
10	L	404	0.0	0.588	6.9	LOS A	4.1	28.7	0.28	0.53	49.0
12	R	422	0.0	0.588	11.3	LOS A	4.1	28.7	0.28	0.74	45.6
Approach		826	0.0	0.588	9.1	LOS A	4.1	28.7	0.28	0.64	47.3
All Vehicles		1246	0.0	0.588	9.5	LOS A	4.1	28.7	0.33	0.68	47.0

Level of Service (Aver. Int. Delay): LOS A. Based on average delay for all vehicle movements. LOS Method: Delay (RTA NSW).
 Level of Service (Worst Movement): LOS A. LOS Method for individual vehicle movements: Delay (RTA NSW).
 Approach LOS values are based on the worst delay for any vehicle movement.
 Roundabout Capacity Model: SIDRA Standard.

PM OUTPUT

MOVEMENT SUMMARY Site: SIPAMU - PM Future

Silverdale Rd / Park Rd / Mulgoa Rd Roundabout

Movement Performance - Vehicles											
Mov ID	Turn	Demand Flow veh/h	HV %	Des. Satn veh	Average Delay sec	Level of Service	95% Back of Queue Vehicles veh	Distance m	Prop. Queued	Effective Stop Rate per veh	Average Speed km/h
South: Park Rd (S)											
1	L	421	0.0	0.498	10.0	LOS A	3.9	27.3	0.61	0.77	46.8
3	R	80	0.0	0.497	12.6	LOS A	3.9	27.3	0.61	0.83	45.0
Approach		501	0.0	0.498	10.4	LOS A	3.9	27.3	0.61	0.78	46.5
North East: Mulgoa Rd (NE)											
24	L	102	0.0	0.380	7.0	LOS A	2.8	19.7	0.29	0.51	48.8
26	R	405	0.0	0.379	10.5	LOS A	2.8	19.7	0.29	0.68	46.2
Approach		507	0.0	0.379	9.8	LOS A	2.8	19.7	0.29	0.65	46.7
West: Silverdale Rd (W)											
10	L	142	0.0	0.178	6.7	LOS A	0.8	5.8	0.17	0.52	49.8
12	R	96	0.0	0.178	11.1	LOS A	0.8	5.8	0.17	0.73	46.1
Approach		238	0.0	0.178	8.4	LOS A	0.8	5.8	0.17	0.62	48.2
All Vehicles		1246	0.0	0.498	9.8	LOS A	3.9	27.3	0.39	0.70	46.9

Level of Service (Aver. Int. Delay): LOS A. Based on average delay for all vehicle movements. LOS Method: Delay (RTA NSW).
 Level of Service (Worst Movement): LOS A. LOS Method for individual vehicle movements: Delay (RTA NSW).
 Approach LOS values are based on the worst delay for any vehicle movement.
 Roundabout Capacity Model: SIDRA Standard.









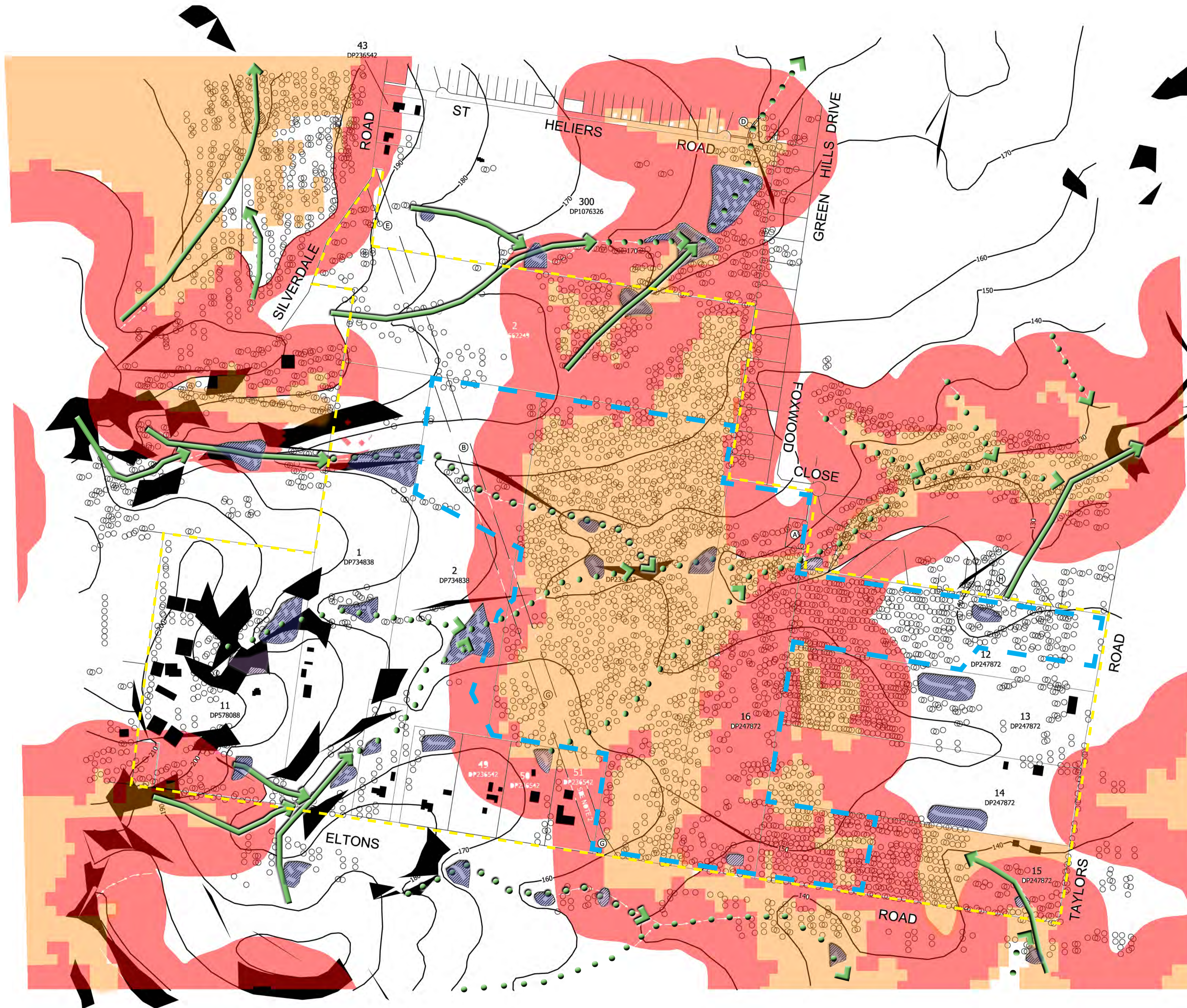

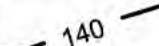

ANNEXURE E

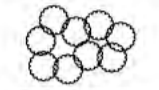
CONSTRAINTS MAP

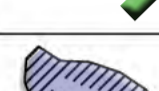
TAYLOR BRAMMER LANDSCAPE ARCHITECTS



LEGEND

-  140 CONTOURS
-  BOUNDARY LINE
-  EXISTING VEGETATION
-  BUILDINGS (INDICATIVE)
-  WATERCOURSE
-  DRAINAGE DEPRESSION
-  WATER DAM
-  > 20% SLOPE
-  BUSH FIRE PRONE LAND VEGETATION 1
-  BUSH FIRE PRONE LAND VEGETATION BUFFER
-  ABORIGINAL ARCHAEOLOGY

A For Development Approval 14.11.11
 ISSUE DESCRIPTION DATE

TaylorBrammer
 TAYLOR BRAMMER LANDSCAPE ARCHITECTS PTY LTD
 AUSTINMER STUDIO
 28 Moore Street, Austinmer
 PO Box 64 Austinmer, NSW, 2515
 T 61 2 4267 5088
 F 61 2 4267 4826
 E southcoast@taylorbrammer.com.au

PROJECT:
 ELTONS ROAD, SILVERDALE

DRAWING TITLE:
 CONSTRAINTS MAPPING PLAN

CLIENT:
 PLANNING INGENUITY

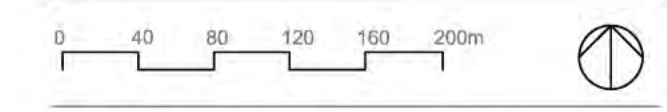

SCALE: 1:4000 @A1
 DATE: 14.11.2011
 DRAWN: MS
 CHECKED: BS
 JOB NO: 11-077W
 DESIGNED: MS
 DRAWING NO: LC01
 REVISION: A



ANNEXURE F

CONCEPTUAL DEVELOPMENT AREAS PLAN

TAYLOR BRAMMER LANDSCAPE ARCHITECTS

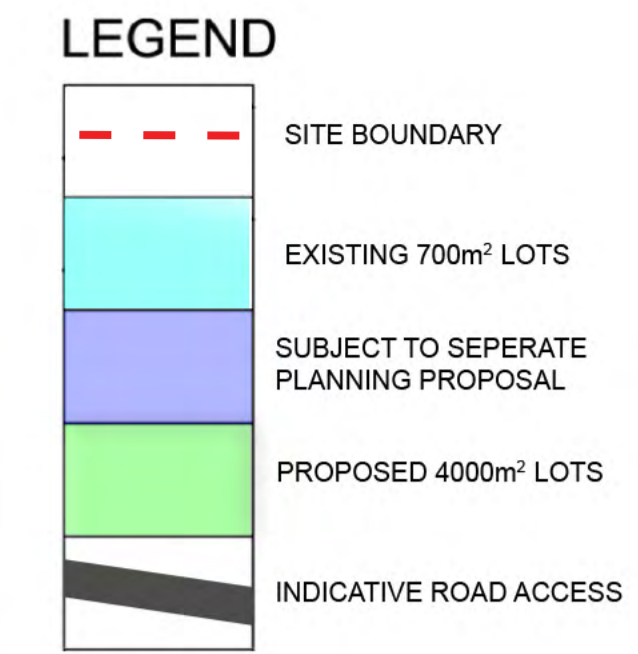
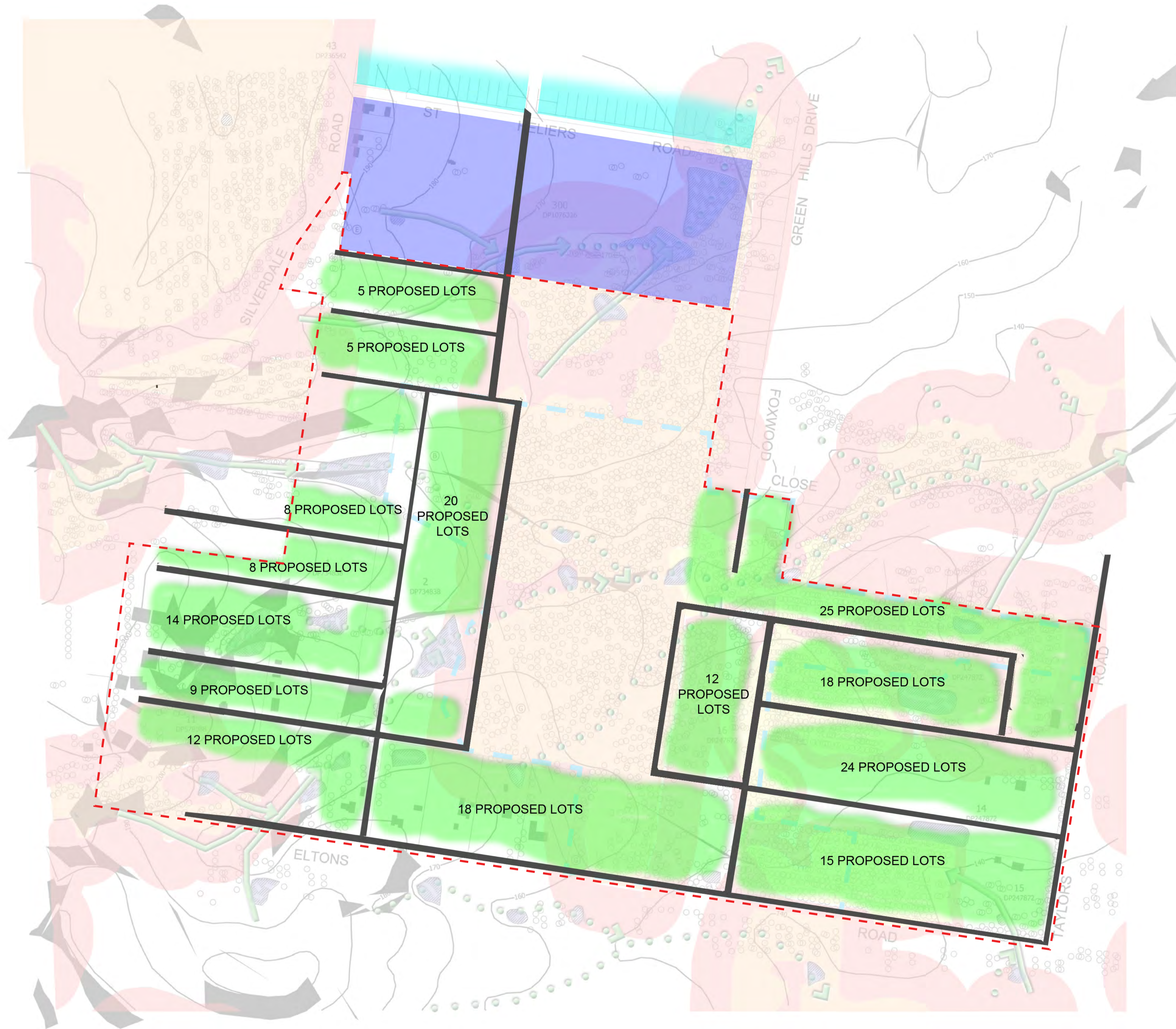

Conceptual Development Areas

Project: Eltons Road Silverdale
Date: 18th January 2012

Project No: 10-031W
Client: Wollondilly Shire Council

Taylor Brammer Landscape Architects Pty Ltd
26 Moore Street / PO Box 3064 Austinmer NSW 2515
Tel: +61 2 4267 5088 Fax: +61 2 4267 4826
Email: southcoast@taylorbrammer.com.au

